

The #1 Magazine in Film Production

Music Video Basics!

STARLOG presents CINE MAGIC™

THE GUIDE TO FANTASTIC FILMMAKING

\$ 4.75

SUMMER
UK £2.00
Number 33



3-D Filmmaking



Stop-Motion Style



Bluescreen Revealed



Action Adventure

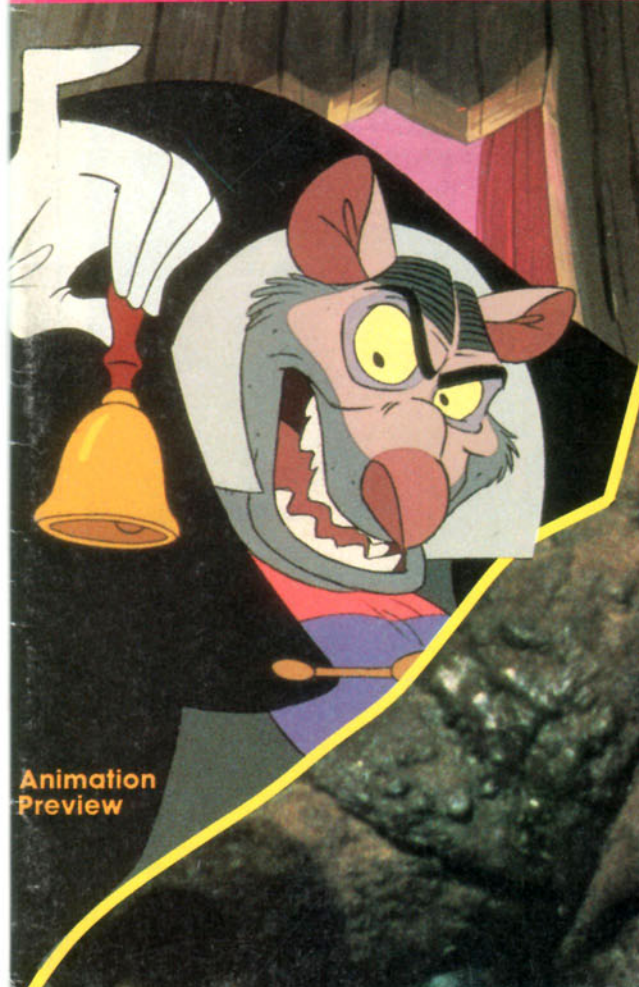

Animation Preview

AND MORE INSIDE...



Official Movie Magazines are packed with interviews, articles, behind the scenes information and dozens of color photos! **64 pages!**

- ROCKY IV \$3.95
- EXPLORERS \$3.95
- OCTOPUSSY \$3.50
- ROCKY IV BOOK \$4.95
- STAR TREK III: THE SEARCH FOR SPOCK \$3.50
- ROCKY III \$3.00
- HIGH ROAD TO CHINA \$3.50
- (Special Combo Package 48 pages of stories plus 8 giant posters!)
- STAR TREK II: THE WRATH OF KHAN \$3.50
- STAYING ALIVE \$3.00
- 2010 \$3.95
- A VIEW TO A KILL \$3.95
- THE BEST OF SYLVESTER STALLONE \$3.00
- ANNIE \$2.95

MOVIE TIE-IN MAGAZINES

THE BLOCKBUSTERS!

Official Poster Magazines contain 10 foldout posters each measuring 16"x22" plus complete story of the films, biographies of the stars and photos!

- ROCKY IV \$3.50
- CONAN THE DESTROYER \$3.00
- RAMBO \$3.50
- SUPERMAN III \$3.00
- STAR TREK III: THE SEARCH FOR SPOCK \$3.00

Official Poster Books unfold to make a giant 22" x 33" poster in full color. On the flip side are articles, biographies and additional color photos.

- ROCKY II \$1.50
- SPACE FANTASY \$1.50
- HIGH ROAD TO CHINA \$1.95
- JOANIE LOVES CHACHI \$1.95
- SCIENCE FICTION SUPERHEROES \$1.50
- FAME \$1.95
- TV SUPERHEROES & ANNIE \$1.75

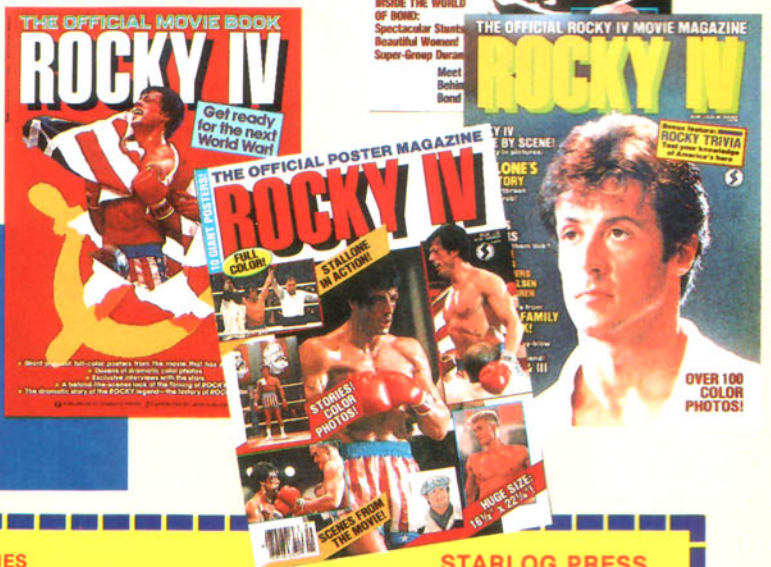

OFFICIAL MOVIE MAGAZINES

- ROCKY IV \$3.95
- ROCKY IV BOOK \$4.95
- A VIEW TO A KILL \$3.95
- EXPLORERS \$3.95
- STAR TREK III: THE SEARCH FOR SPOCK \$3.50
- STAR TREK II: THE WRATH OF KHAN \$3.50
- OCTOPUSSY \$3.50
- ROCKY III \$3.00
- BEST OF SYLVESTER STALLONE \$3.00
- HIGH ROAD TO CHINA \$3.50
- STAYING ALIVE \$3.00
- 2010 \$3.00
- ANNIE \$2.95

OFFICIAL POSTER MAGAZINES

- ROCKY IV \$3.50
- RAMBO \$3.50
- STAR TREK III: THE SEARCH FOR SPOCK \$3.00
- CONAN THE DESTROYER \$3.00
- SUPERMAN III \$3.00

OFFICIAL POSTER BOOKS

- ROCKY II \$1.50
- HIGH ROAD TO CHINA \$1.95
- SF SUPERHEROES \$1.50
- TV SUPERHEROES & SPACE FANTASY \$1.50
- JOANIE LOVES CHACHI \$1.95
- FAME \$1.95
- ANNIE \$1.75

STARLOG PRESS
475 Park Avenue South
New York, NY 10016

Send cash, check or money order to:

NAME _____

ADDRESS _____

CITY _____

STATE _____ ZIP _____

New York State residents please add sales tax. Allow 6 to 8 weeks for delivery.

Please add postage and handling charge for each publication ordered.
Movie Magazine—\$1.50; Poster Magazine—\$1.50; Poster Book—\$1.00

Editor's Bench **4**

Fill Light

Build your own 600-watt fill light. By Thomas Fuller. **6**

3-D Movies

Make your own 3-D movies! By Michael Riley. **12**

Searching for 3-D

Filmmaking in 3-D is still an experimental format. By David Hutchison. **18**

Music Videos

The basics of taking a song from vinyl to video. By Rex Piano. **22**

Great Mouse Detective

Disney's latest animated feature. By David Duward. **25**

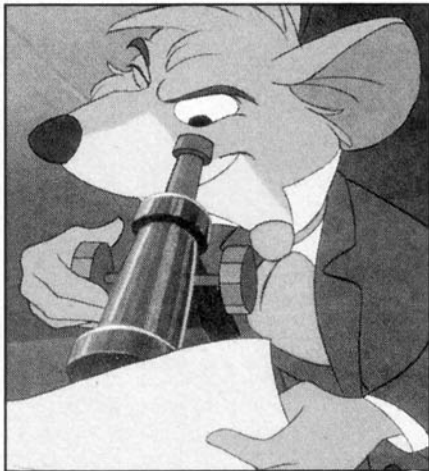

Blue Screen

Coming to terms with blue screen photography. By Paul Mandell. **32**

On Location

Walter Pitt's winning short film, *Welcome Back Mr. Fox*. By John Clayton. **36**

Friendly Plastic

Fighting the clock with tooth and nail. By John Dods. **38**

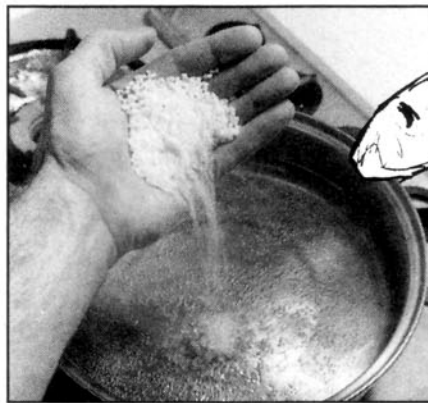

Back to the Future

Artist Andrew Probert talks about designing the DeLorean time machine for last summer's biggest hit movie. By David Hutchison. **41**

Stop Motion with Style

Developing your own stop-motion animation style. By Douglas Borton. **45**

Producers' Bulletin Board

Latest news of our readers' productions. **50**

Festivals

News on film festivals around the country. **53**

Grip Kit

Useful accessories for filmmakers. **54**

Making Monsters

Create your own creatures. Cheap—and fun! By Thomas Viall. **58**



Cinemagic Marketplace

Classified advertising and announcements. **60**

Filmmakers' Forum

Readers' correspondence about fantasy filmmaking. **63**

Stop-Motion Studio

Illusion Engineering's precision armature kits. **66**



Issue #33

Publishers

Norman Jacobs/Kerry O'Quinn

Associate Publisher

Rita Eisenstein

Assistant Publisher

Milburn Smith

V.P. Circulation Director

Art Shulkin

Creative Director

W.R. Mohalley

Production Director

Bob Sacks

Editor

David Hutchison

Managing Editor

John Clayton

Art Director

Emily Sloves

Designers

Maggie Hollands

Ann Nelson

Lewis Robison

Daniel Recchia

Editorial Contributors

David Bacon

Douglas Borton

John Dods

James Duward

Thomas Fuller

Carl Kurte

Paul Mandell

Rex Piano

Walter Pitt

Andrew Probert

Tom Viall

Special Projects

Mike Hadley

Rex Piano

Damon Santostefano

Production Assistants

Connie Bartlett

Ed Berganza

Maria Damiani

Elizabeth DeJesus

Joe Dunn

Richard Franzoso

Brent Hatcher

Peter Hernandez

Penny Layne

Financial Manager

Joan Baetz

Advertising Information: Rita Eisenstein
(212) 689-2830

Editor's BENCH

I must have been out of my mind. How could I possibly have done this to myself? I scheduled two of the most difficult technical topics for the same issue: travelling mattes and 3-D movies. Both topics have been in the planning stages for many months, so I guess they just happened to come up together.

The article on bluescreen travelling mattes has been included in CINEMAGIC, not as a how-to, but as an "Oh, I see" item. I do not expect any of our readers to run out and start making their own bluescreen shots; in fact, the purpose of this article is to discourage you from attempting it. From time to time, I get letters from readers who want to shoot bluescreen mattes in Super-8, but run into problems. I remember one letter which began: "I am shooting my models in front of a blue screen, so I can matte them into a space background. But, I am having problems getting the blue to disappear . . ." Paul Mandell's blue screen question-and-answer format should give you a basic understanding of the process, but it's strictly for the pros . . . or brave amateurs with access to an optical lab and lots of money.

While 3-D movies are a lot more accessible to amateurs than bluescreen, the 3-D process is not for the faint of heart, either. The first article by Michael Riley explains the basics of 3-D filmmaking from a beginner's point of view and describes the construction of an inexpensive rig, which will allow almost anyone to experiment in 3-D with a minimum of fuss and expense. If you get the bug, and 3-D requires passion, then the second article will acquaint you with some of the options available to people who want to get serious about 3-D.

One of the most popular ways to get started in video is through the production of music videos. Producer/director Rex Piano takes you through the basic steps of music video production, and lets you know what would be involved if you wanted to graduate to broadcast standard.

We have two construction articles in this issue. Thomas Fuller gives us an inexpensive alternative to buying movie lights and Thomas Viall describes his method for building hand puppet monsters on a very low budget. Animation fans should follow Douglas Borton's discussion of style in stop-motion animation, and then explore a low-cost source of professional animation armature parts from a pair of midwestern film buffs.

I have included two articles for the many "armchair filmmakers" who read this magazine: a preview of Disney's latest animated film *The Great Mouse Detective* and a brief interview with British filmmaker Stephen Frears. Frears' remarkable film, *My Beautiful Laundrette*, is currently playing around the country. It was shot in 16mm and blown up to 35mm for theatrical release. It just goes to show that you don't have to work in 35mm to get into the big time.

All in all, it looks like a very exciting issue (there are other great articles that I haven't even mentioned), it has also been a very complicated issue to put together. As I sit here typing this, I am wondering what is going to go wrong. I have learned over the years, that no matter how careful you are or how many months you plan things . . . something can always go wrong. Last issue it was the *Ten Commandments* color. The printer reversed the red and yellow plates, making the illustrations for that article look like they had been sprayed Day-Glo pink.

I have my fingers crossed that all will go well with this issue. The travelling matte article is particularly susceptible. If just one press operator or printing plate maker is thinking about his girl friend or what's going to happen after he gets off work, it can be disastrous. Perils of publishing, it's called. In any case, this issue of CINEMAGIC is chock full of information, which can be found no where else. You may thank our skilled writers and contributors whose names are listed in the left hand column.

—David Hutchison

CINEMAGIC is published quarterly by STARLOG PRESS, INC. 475 Park Avenue South, New York, NY 10016. This is issue #33 (Volume 7, No. 3) for Summer. ISSN #0090-3000. Content is © 1986 by STARLOG PRESS, INC. All rights reserved. Reprint or reproduction of any material in part or in whole without written permission from the publishers is strictly forbidden. CINEMAGIC accepts no responsibility for unsolicited manuscripts, photos, art or other material, but if freelance submittals are accompanied by a self-addressed, stamped envelope, they will be considered and, if necessary, returned. Products advertised are not necessarily endorsed by CINEMAGIC, and any views expressed in editorial copy are not necessarily those of CINEMAGIC. Subscription rates: \$13.98 for one year (four issues) delivered in the U.S., Canada and Mexico, foreign subscription \$18.98 in U.S. funds only. **New Subscriptions:** send directly to CINEMAGIC, c/o STARLOG PRESS, INC., 475 Park Avenue South, New York, NY 10016. Notification of **change of address** or **renewals** send to CINEMAGIC, Subscription Dept., P.O. Box 142, Mt. Morris, IL 61054-0142. **Postmaster:** Send change of address to CINEMAGIC Subscription Dept., P.O. Box 142, Mt. Morris, IL 61054-0142. Second class postage paid at New York, NY and additional mailing offices. Printed in U.S.A.

CINEMAGIC BACK ISSUES

#1—Backwinding Super-8; Construction.
SOLD OUT!

#2—Spaceship Model Making; Blood Makeup; Smoke Generator; Light Beam Effects; Making an SF Logo.

#3—Robot Construction; Developing an Animation Style; Fluid Art Animation; Electronic Special Effects;

#4—Aerial Image Optical Printer—Construction; Wire Armatures; A-B Rolling; More Electronic Special Effects; Fog and Mist Effects.

#5—Aerial Image Optical Printer—Usage; Widescreen Super-8; Slit Scan Effects; Glistening Eyes for Stop-Motion Models.



#6—Amazing Electronic Gadgets—cheap!; Bring Your Alien to Life—Latex Masks; Basic Editing Techniques; Invisible Man Effects.

#7—Basic Cartoon Animation; Claymation; Kaleidoscope Effects; Profile—Damon Santostefano.



#8—Video Tape Transfers; Reverse Filming Effects; Lab Services; Clash of the Titans Preview; Profile—Paul Vitous and Mike Antonucci.

#9—Animating Pogo; Lithographic Film Titles; Sets on a Shoestring; Profile—The Langley Punks.

#10—Mastering Mattes; Zero Budget Sets; CINEMAGIC/SVA Awards Night; Building a Super Soundtrack; Pen Set Ball-and-Socket Armatures; Profile—Joe Ritter.

#11—Glass Shots; Miniature Explosions; Figure Animation; Bloody Hair Hunks; Profile—Koch and Lohr.

#12—Makeup Magic—Latex Appliances; Rotoscoping; Zero Budget Ray Gun; Profile—Dean Barnes and Greg Gilger.



#13—Slit Scan; Creating UFO "Lightships"; Model Interiors; More Electronic Special Effects; The Saturn Machine; Profile—Bonnie Borucki.



#14—Storyboarding; Sound Effects Generator; Miniature Devastated Cities; Charles Jones' 16mm Space Epic. Profile—Jerry Parisi.

#15—Script Writing; Miniature Lighting Special Effects. Careers—George Lucas and John Dykstra; Super Depth in Dioramas; Profile—Ralph Miller.



#16—Script Writing, Part 2; Electronic SPFX—LED Circuits; Flat Art Explosions; Careers—Frank Van der Veer; Build Your Own Camera Crane; Profile—Steve Parady and Bill Rudow.

#17—Script Writing, Part 3; Production Managing Low Budget; Electronic SPFX—Light "Chaser"; CINEMAGIC/SVA Contest Rules; Secrets of Graphic Gore; Profile—Chris Callaghan and Bob Griffith.

#18—Making Monsters; Tie-Downs for Animation Models; Accessories for Filmmakers; Electronic SPFX—Redesigned Sound Generator; Profile—Al Magliochetti.



#19—CINEMAGIC/SVA Awards Night; Build Your Own Cob Web Spinner; High School Werewolf; Careers—George Melles; Electronic SPFX—Lighting Gadgets; Front Light/Back Light Animation Technique.



#20—Articulated Full Head Masks; Dream Screen; Precision Ball-and-Socket Armatures Parts; Electronic SPFX—Sync Strobe; Profile—Joey Ahlbum.

#21—Custom Spaceships; Electronic SPFX—DC Strobe; Careers—Robert Short; Foam Rubber Build-up Method; Creating a Monster; Profile—Deborah Von Moser.

#22—Miniature Landscapes; Electronic SPFX—Strobe Accessories; Title Spinner; Ball-and-Socket Armature Parts; Making Creature Makeup; Profile—David Casci.

#23—Microcomputer Animation; Make Your Own Cross-Star Filter; Animation Armatures; CINEMAGIC Back Issues Guide; Mark Sullivan's Highrise; On Location—Zyzak is King.

#24—Awards Night; Scratch-Building Model Spaceships; Glowing Eyes for Creature Masks; Animation Tips; Easy Armatures; Careers—Roger Corman's Millennium Studios; EZ Effects—Make Your Own Fog Filters.

#25—Build Your Own Camera Stabilizer; Color Filter FX; Shooting Publicity Stills; Make Your Own Armor; Electronic SPFX—Digital Frame Counter; On Location—Dr. Dobermind

#26—Hand Puppet Monsters; Electronic SPFX—Intervalometer; "Star Zoomer"; Three-Headed Armature; "Is Stop Motion Dead?" Melting Man FX; Animator Tony Laudati; On Location—Mendel Marks.

#27—New Double-size format! The Art of Stop Motion; Split-Screen FX; Rear Screen Techniques; Supply Sources; Sculpting Clay; Jimmy Picker's Sundae in New York; Miniature Planets; Ripple Title FX; Casting Molds; Careers—Jim Danforth, Part I; Armatures; On Location—Raygun's Nightmare.

#28—Organizing a Film; Jim Danforth on Stop-Motion; A Stop-Motion Epic; Underwater Filming; Pete Peterson; Festivals; Headless Dummies; Casting Actors; Action Stunts; Stop Motion Rock Video; Pinocchio; Car Crashes; Makeup FX; Beamsplitter Ray FX.

#29—Special Cable-Control Issue! Introduction to C-C; Building a C-C Control Handle; Building a C-C System; Careers: Jim Danforth, Part II; Marcel Delgado—Master of Miniatures; Filmmaker Karel Zemen; E-Z FX—Animation Compound; George Pal's Wonderful World of the Brothers Grimm; Miniature Mechanical Monsters.

#30—A Harryhausen Gallery; Build an Aerial Brace; Beam-Splitter Techniques; Makeup Effects; Build an Animation Gauge; Jim Danforth, Part III; Lost Sequence From King Kong; Sculpting Tools; Electronic Blinking Eyes; Stop-Motion Fantasy—Frog and Toad are Friends; More!

#31—Parting the Red Sea in DeMille's Ten Commandments; Synthetic Flesh; Eyes for Monsters; Moire Pattern FX; Rear Projection; Stop-Motion Exercises; Festivals Guide; Careers: Phil Kellison; On Location—Strange Tangents.



#32—Ten Commandments—Part 2; Implooding Head FX; Sleeping Beauty; Phil Kellison—Part 2; How Not to Make Movies; More!

CINEMAGIC, c/o Starlog Press, Inc., 475 Park Ave. South, New York, NY 10016.

Add postage and handling to your order: \$.80 for one issue; \$1.14 for two; \$1.60 for three; \$2.00 for four; \$2.40 for five; \$2.70 for six, seven, eight.

- Check issues desired.
- | | | |
|--|--|--|
| <input type="checkbox"/> # 2 — \$3.00 | <input type="checkbox"/> # 12 — \$3.00 | <input type="checkbox"/> # 22 — \$3.00 |
| <input type="checkbox"/> # 3 — \$3.00 | <input type="checkbox"/> # 13 — \$3.00 | <input type="checkbox"/> # 23 — \$3.00 |
| <input type="checkbox"/> # 4 — \$5.00 | <input type="checkbox"/> # 14 — \$3.00 | <input type="checkbox"/> # 24 — \$5.00 |
| <input type="checkbox"/> # 5 — \$3.00 | <input type="checkbox"/> # 15 — \$3.00 | <input type="checkbox"/> # 25 — \$3.00 |
| <input type="checkbox"/> # 6 — \$3.00 | <input type="checkbox"/> # 16 — \$3.00 | <input type="checkbox"/> # 26 — \$3.00 |
| <input type="checkbox"/> # 7 — \$3.00 | <input type="checkbox"/> # 17 — \$3.00 | <input type="checkbox"/> # 27 — \$4.50 |
| <input type="checkbox"/> # 8 — \$3.00 | <input type="checkbox"/> # 18 — \$3.00 | <input type="checkbox"/> # 28 — \$4.50 |
| <input type="checkbox"/> # 9 — \$3.00 | <input type="checkbox"/> # 19 — \$3.00 | <input type="checkbox"/> # 29 — \$4.50 |
| <input type="checkbox"/> # 10 — \$3.00 | <input type="checkbox"/> # 20 — \$5.00 | <input type="checkbox"/> # 30 — \$4.50 |
| <input type="checkbox"/> # 11 — \$3.00 | <input type="checkbox"/> # 21 — \$3.00 | <input type="checkbox"/> # 31 — \$4.50 |
| | | <input type="checkbox"/> # 32 — \$4.50 |

NAME _____

ADDRESS _____

CITY _____

STATE _____ ZIP _____

Building a Better Light Bulb

Build this low-cost 600-watt fill light and save a bundle on your lighting equipment budget.

By THOMAS F. FULLER

Whether you work with film or video you need light, and lots of it. Every amateur producer knows how expensive professional quality lighting equipment is, and how inadequate the hobbyist grade lighting gear can be with its hot spots, low light output, and overall poor construction.

To light some sets you may require several units to achieve the desired effect, and the two or three lights that you may now have just are not enough, forcing the scene to be changed and the set reworked, usually with less than satisfactory results.

I have designed an inexpensive and easily built tungsten-halogen lighting unit that is quite powerful, very versatile, and quickly put together by anyone basically familiar with workshop technique. You will need the readily available materials listed at the end of this article.

Construction

The first step in building your fill light is the construction of the lamp house, made from the aluminum chassis box. The inner and outer halves of the box are drilled and punched as shown in the Diagram A, the large ventilation holes being very important for safe operation of the finished unit. These 1/2-inch diameter holes are most easily made using a Greenlee Radio Chassis Punch, available from a large hardware store or industrial tool supply house. Without this punch, however, you can make the holes by drilling with the largest bit you have, then enlarging the hole to size with a round file.

The outer half of the box will be bolted to the outside bottom of the mixing bowl, which will serve as the reflector. Measure carefully to assure correct alignment of all parts in the finished unit. Drill a small pilot hole in the front center of the box, as well as in the center of the mixing bowl. Line up these holes, making sure that the box is centered on the bottom of the bowl *before* drilling the mounting holes through the bowl. Fasten both of these parts together with short #10 round head machine screws, making sure that the pilot holes are still aligned.

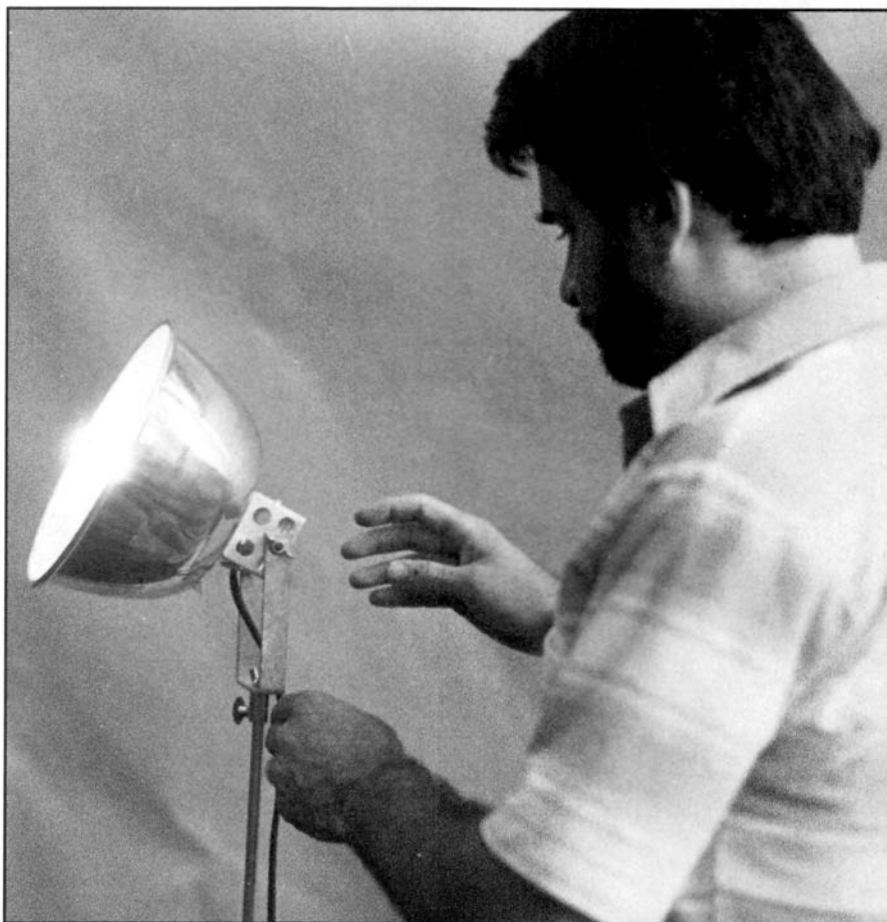

Author Thomas Fuller with the completed 600-watt fill light project.

You are now ready to cut the 1-and-3/8-inch diameter center hole. This hole is also most easily done with a large Greenlee punch, but an adjustable rotary hole cutter held in a bit brace will also do. In the absence of either of these tools, the center hole can be made by drilling a ring of closely spaced 1/8-inch diameter holes and filing out the metal in between. To prevent serious cuts, be sure to smooth the edge of the hole with emery paper.

Remember, you will be cutting through two layers of metal at the same time, the chassis box and the reflector bowl being already fastened together. Use the pilot

hole as the center point for whatever kind of cutting tool you use. For even illumination, finish the reflector by rubbing the inside of the bowl with steel wool in a smooth, circular motion.

Next, make the mounting yoke from a strip of steel flatstock, bent and drilled as shown in Diagram B. The inside dimensions of the yoke should be 2 7/8 x 4 1/2 inches. The easiest way to bend the flatstock is to file a shallow groove at the point where the bend is to be made, and then clamp the stock into a vise and hammer lightly for a sharp, even bend.

Install a 3/8-inch light stand adapter

DIAGRAM A

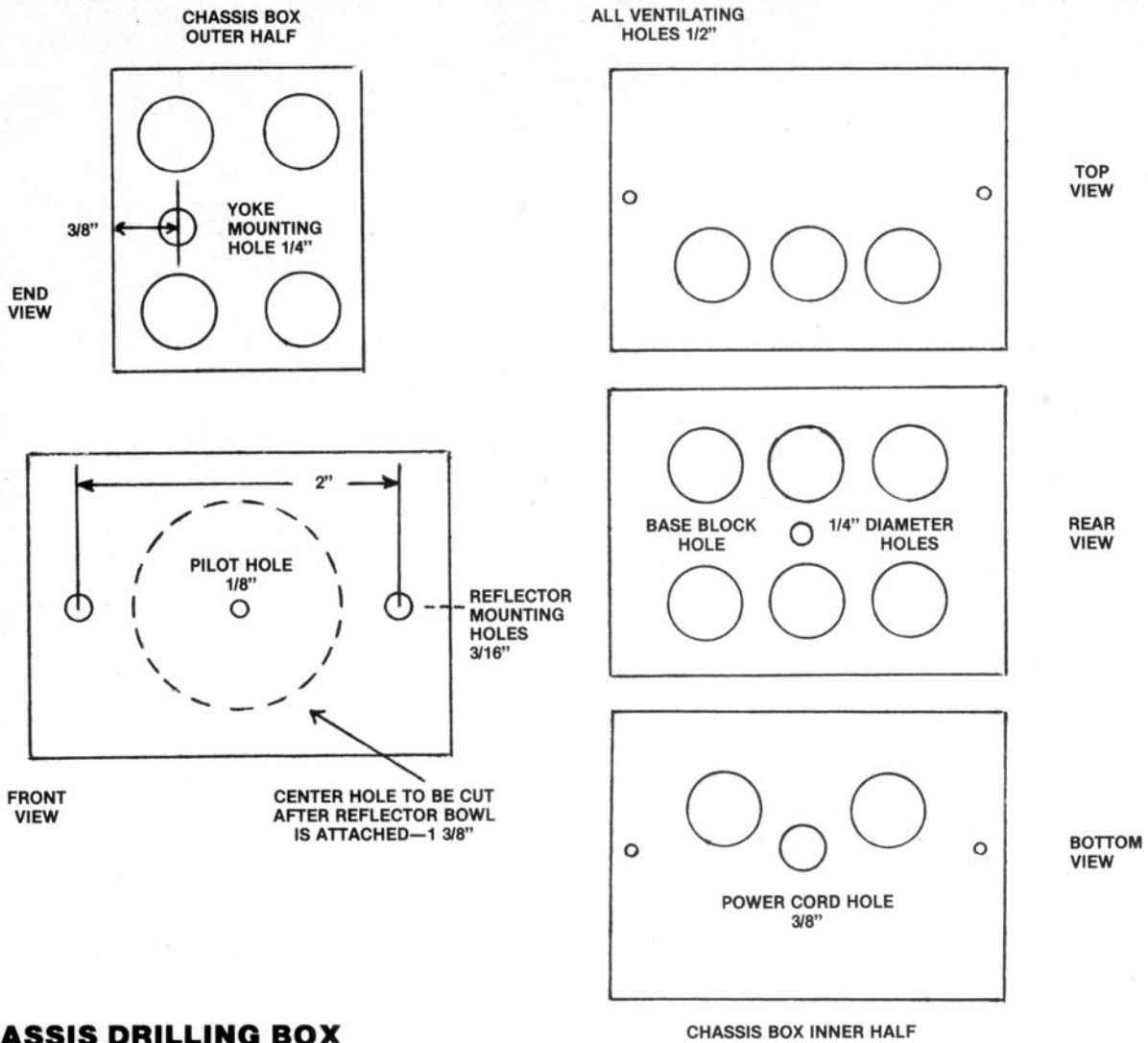

CHASSIS DRILLING BOX

through the bottom 1/4-inch diameter hole, and attach the completed yoke to the reflector assembly using the 1/4-inch holes in each side of the lamphouse. Use short 1/4-20 stove bolts with wing nuts on the outside, as shown on page 29.

The 600-watt DYH lamp is fitted with a pair of large spade lugs, bent and crimped to the two pins at the ceramic base. Be sure to bend the lugs *before* fastening them to the pins. I have found that it is much easier to place a crimp in the shank of the pre-bent lug and then press it onto the pin, rather than trying to crimp the lug with it already in place on the pin. Don't force the lugs onto the pins; only moderate finger pressure should be used. If a lug doesn't easily fit, discard it and try another that has been crimped less. Work carefully to avoid loosening the pins from the lamp base.

The lugs will hold the lamp in place on the lamp base block, made from a 1 5/8 x 1 5/8-inch piece of hard wood as shown in Diagram E. The two wood screws hold both the lamp lugs as well as the power

View of lamphouse interior. Large ventilation holes in chassis box are important to prevent overheating. Use only 16-gauge rubber covered heater cord for electrical safety. Vinyl grommet placed into power cord hole prevents abrasion.

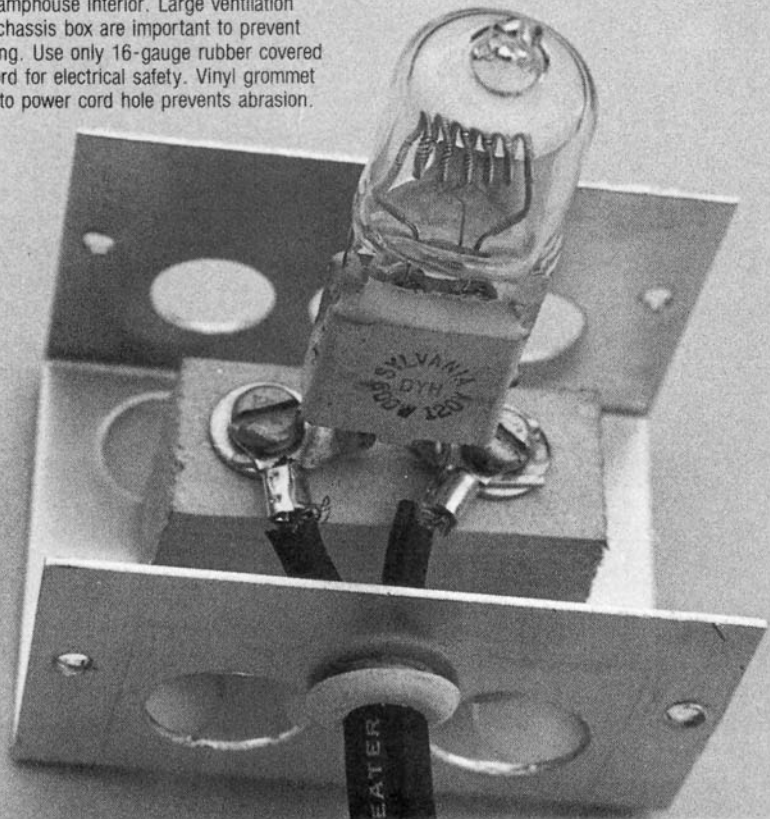

MOUNTING YOKE

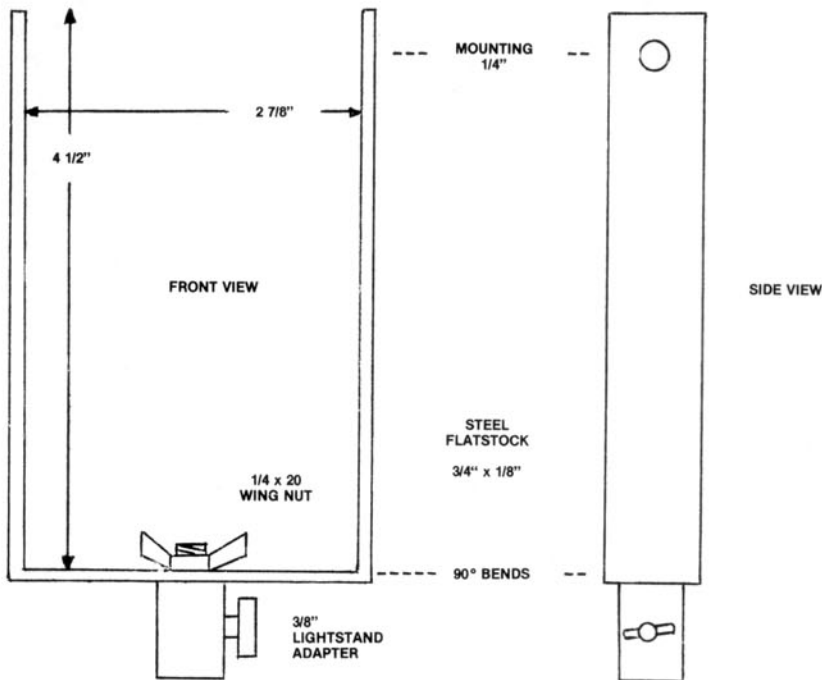

DIAGRAM B

HEAT DEFLECTOR PLATES

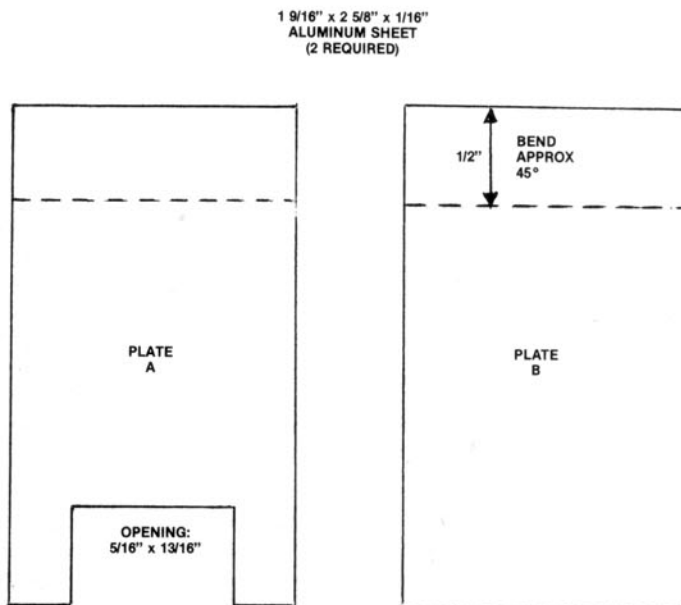
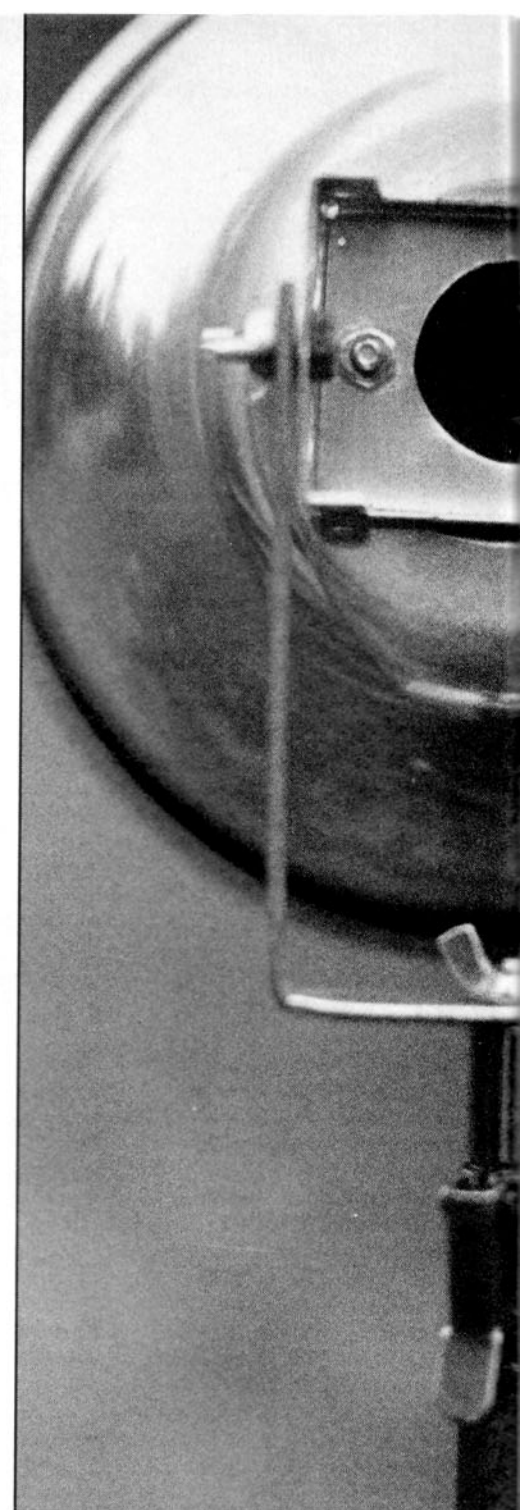
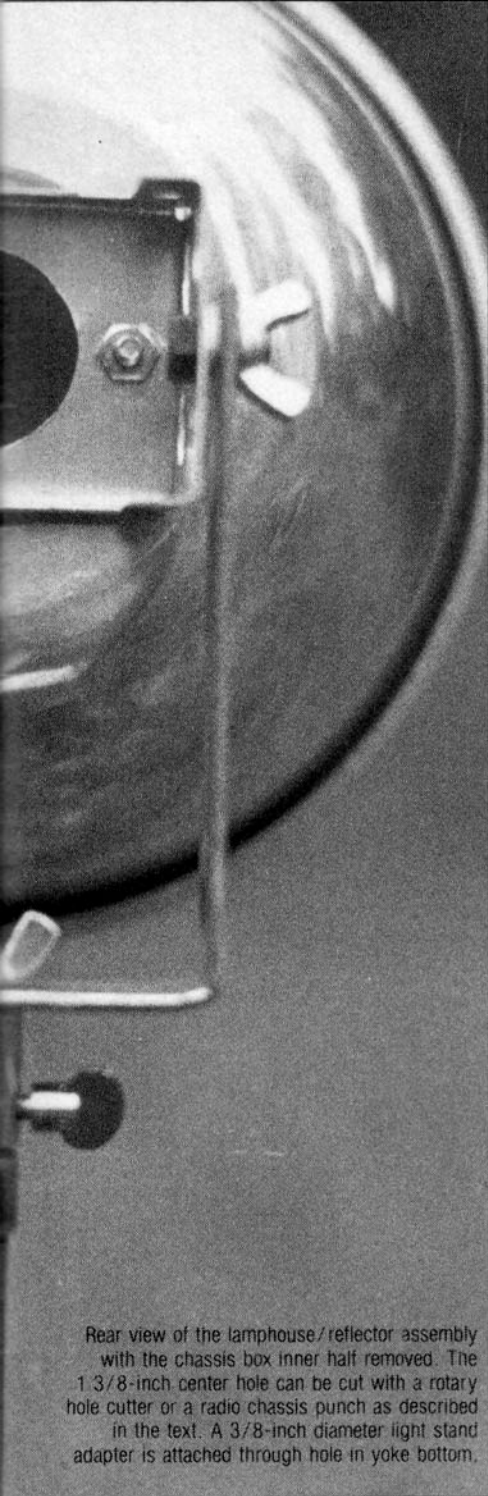

DIAGRAM C

cord lugs. The block itself is secured into the inner half of the lamphouse by a wood screw from the outside. Install a vinyl grommet to protect the power cord from abrasion where it passes through the box. Photo (on page 27) shows the completed inner half of the lamphouse.

Slide both lamphouse halves together and secure them with the four sheet metal screws provided. The tip of the lamp should protrude no less than 1 3/4 inches into the reflector if all has gone well. If necessary, loosen the two lamp mounting screws (*Not* the reflector mounting screws) slightly and gently move the lamp for exact centering within the reflector. Retighten the lamp screws carefully. Dur-





Rear view of the lamphouse/reflector assembly with the chassis box inner half removed. The 1 3/8-inch center hole can be cut with a rotary hole cutter or a radio chassis punch as described in the text. A 3/8-inch diameter light stand adapter is attached through hole in yoke bottom.

ELECTRICAL SCHEMATIC

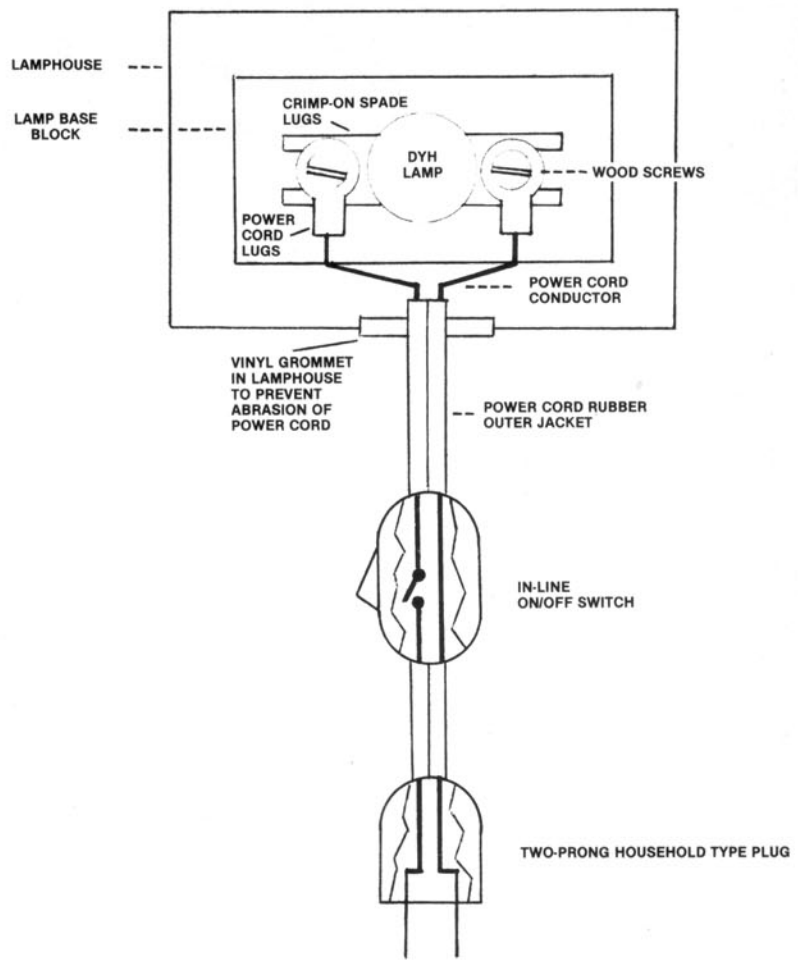

DIAGRAM D

LAMP BASE BLOCK

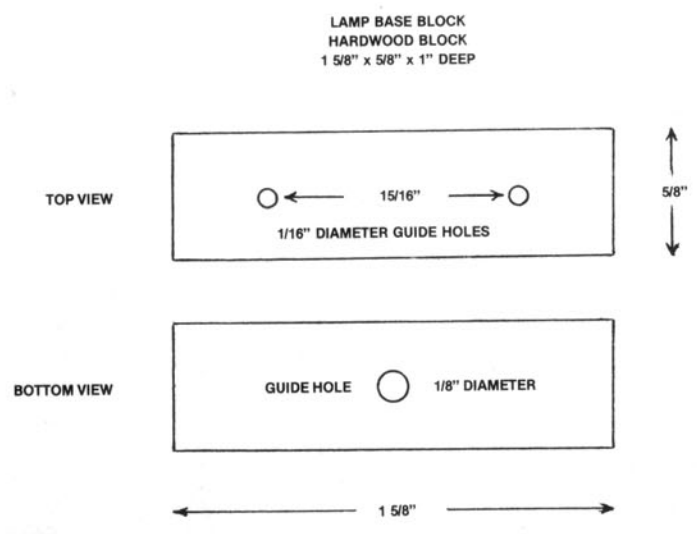

DIAGRAM E

ing construction be sure to always handle the DYH lamp with care.

The final stage of this project is to make and install the heat deflector plates. These simple yet crucial parts are cut from scraps of sheet aluminum as shown in Diagram C. For convenience, an extra #270-235 chassis box can be purchased and its inner half "cannibalized" for two pieces of exactly the right size. The notch in the top plate must be cut accurately, so that it fits around the rectangular lamp base with as little clearance as possible. Also, the mating edges of the top and bottom plates should fit together tightly, as the purpose of these deflectors is to pre-

(continued on page 29)

DISCOUNT SOUND

NEW!



THE COMPANY OF WOLVES
Classic, folk and original melodies by George Fenton mix in this dark, haunting orchestra-with-organ score.

NEW!



ALFRED HITCHCOCK
New digital recording (Utah Symphony) from "Family Plot" John Williams, "Suspicion" Waxman, "Strangers On A Train" & "Notorious."



THE AVENGERS
Themes from the series, plus THE NEW AVENGERS and THE PROFESSIONALS.



STARMAN
Jack Nitzsche's haunting, romantic score to John Carpenter's exciting alien adventure.



HALLOWEEN
Chill all year 'round to music composed and performed by John Carpenter.



BATTLE BEYOND THE STARS
Exciting orchestral score for humorous SF adventure. RARE!



HALLOWEEN II
Music to scream to, by the maker of Halloween.

NEW!



TEEN WOLF
Hilarious, hit Michael J. Fox film with hot, pop music by Miles Goodman.

NEW!

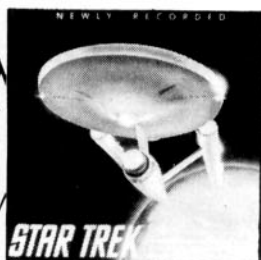

STAR TREK TV—Vol. 1 & 2
Music from the classic series that started it all. Available in two separate volumes.



BUCK ROGERS
The original motion picture soundtrack, composed and conducted by Stu Phillips.



STAR TREK II: WRATH OF KHAN
James Horner's score for the popular film. Digital.

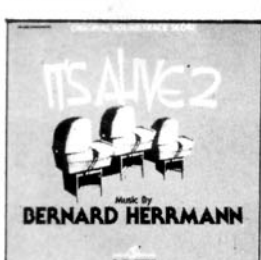

IT'S ALIVE 2
Bernard Herrmann's 50th and last soundtrack score.



LASSITER
Ken Thorne's driving orchestral soundtrack to Tom Selleck detective caper.



SECRET AGENT FILE
18 cuts in all! Bond films, "Ace of Spies," "U.N.C.L.E.," "I Spy" & others.



SILENT RUNNING
Music by Peter Schickele; songs by Joan Baez. Newly remastered.

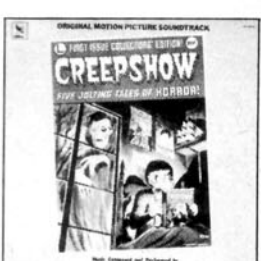

CREEPSHOW
Soundtrack composed by John Harrison. Wild synthesizer music and effects.



TOP SECRET
Maurice Jarre conducts Royal Philharmonic Orchestra (digital-mix) for this lush, madcap comedy.



THE LAST STARFIGHTER
Thrilling music by Craig Safan from computer-graphics space adventure.



CLOSE ENCOUNTERS OF THE THIRD KIND
John Williams's soundtrack score.



MUSIC FROM THE 21st CENTURY
Tangerine Dream, Neil Norman and others. Available in cassette or LP.

TRACK SHOPPER



THE TWILIGHT ZONE

Original soundtrack music from Rod Serling's classic TV series — released for the first time, complete with extensive notes on the episodes and composers.

VOLUME I:

Music by Bernard Herrmann, Franz Waxman, Jerry Goldsmith, Van Cleave (includes Main Title theme by Marius Constant).

VOLUME II:

Music by Fred Steiner, Bernard Herrmann, Jerry Goldsmith, Nathan Scott (includes Herrmann's Main & End Title themes).

VOLUME III:

Music by Jerry Goldsmith, Bernard Herrmann, Nathan Van Cleave, Leonard Rosenman and Marius Constant's alternate Main & End Title music.

VOLUME IV:

Music by Jerry Goldsmith, Fred Steiner, Van Cleave, plus Bernard Herrmann's alternate Main and End Title themes.

VOLUME V:

Music by Goldsmith, Fred Steiner, Van Cleave and Jeff Alexander—plus alternate titles by Bernard Herrmann.



ICE MAN

Lush, raw score by Bruce Smeaton to Tim Hutton adventure/drama.



OUTER SPACE SUITE

Music for TV & radio programs by the great Bernard Herrmann!



SUPERGIRL

Composer Jerry Goldsmith and National Philharmonic Orchestra with a thrilling original soundtrack.



THE ROAD WARRIOR

The hard-driving sequel to Mad Max with music by Brian May.



STAR WARS TRILOGY

For 1st time: the 3 themes on 1 album! John Williams' masterpiece!



MAD MAX

Dynamic, percussive music to futuristic adventure film.



SHEENA

Soundtrack score by Richard Hartley; wild film escapades of the popular comic book heroine.



YOR-HUNTER FROM THE FUTURE

Unusual past/future heroic adventure music by John Scott & De Angeles.

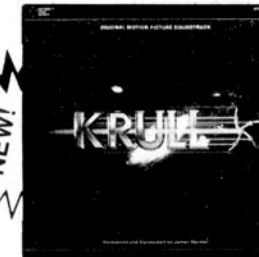

KRULL

Rich orchestral score by James Horner for magical adventure film.

DISCOUNT SOUNDTRACK SHOPPER ORDER FORM—SAVE OVER 10%

Send cash, check or money order

TEEN WOLF
List \$9.95 **Special: \$8.95**

STAR TREK TV Vol. 1
__Album __Cassette
List \$10.98 **Special: \$9.98**

STAR TREK TV Vol. 2
__Album __Cassette
List \$10.98 **Special: \$9.98**

THE LAST STARFIGHTER
List \$9.95 **Special: \$8.95**

ICE MAN
List \$9.95 **Special: \$8.95**

YOR
List \$9.95 **Special: \$8.95**

KRULL
List \$9.95 **Special: \$8.95**

TOP SECRET
List \$9.98 **Special: \$8.98**

STAR TREK II:
WRATH OF KHAN
List \$9.98 **Special: \$8.98**

AVENGERS
List \$9.98 **Special: \$8.98**

STARMAN
List \$9.98 **Special: \$8.98**

STARLOG PRESS

HALLOWEEN
List \$9.98 **Special: \$8.98**

BATTLE BEYOND THE
STARS
List: \$8.98 **Special: \$7.98**

HALLOWEEN II
List \$9.98 **Special: \$8.98**

IT'S ALIVE 2
List \$9.98 **Special: \$8.98**

LASSITER
List \$9.98 **Special: \$8.98**

ALFRED HITCHCOCK
List \$9.98 **Special: \$8.98**

SILENT RUNNING
List \$9.98 **Special: \$8.98**

CREEPSHOW
List \$9.98 **Special: \$8.98**

SECRET AGENT FILE
__Album __Cassette
List \$8.98 **Special: \$7.98**

CLOSE ENCOUNTERS
List \$9.98 **Special: \$8.98**

MUSIC FROM THE 21ST
CENTURY
__Album __Cassette
List \$9.98 **Special: \$8.98**

475 Park Avenue South
New York, NY 10016

BUCK ROGERS
List \$9.98 **Special: \$8.98**

THE COMPANY OF WOLVES
List \$9.98 **Special: \$8.98**

TWILIGHT ZONE I
List \$9.98 **Special: \$8.98**

TWILIGHT ZONE II
List \$9.98 **Special: \$8.98**

TWILIGHT ZONE III
List \$9.98 **Special: \$8.98**

TWILIGHT ZONE IV
List \$9.98 **Special: \$8.98**

OUTER SPACE SUITE
List \$9.98 **Special: \$8.98**

SUPERGIRL
List \$9.98 **Special: \$8.98**

ROAD WARRIOR
List \$9.98 **Special: \$8.98**

STAR WARS TRILOGY
List \$10.98 **Special: \$9.98**

MAD MAX
List \$9.98 **Special: \$8.98**

SHEENA
List \$9.98 **Special: \$8.98**

NAME _____

ADDRESS _____

CITY _____

STATE _____

ZIP _____

POSTAGE AND HANDLING CHARGES

U.S.A. — \$2.00 for first record
\$1.50 for each additional record
Canada — \$3.72 for first record
\$1.00 for each additional record

Foreign — \$4.50 ea. record

Total for records: \$ _____

Add postage: \$ _____

Total enclosed: \$ _____

California residents include 6½% sales tax.

(Payment in U.S. funds only.)

NOTE: If you do not want to cut this page, send order on another piece of paper. Please allow 4 to 6 weeks for processing and delivery. All records guaranteed! Ask for these exciting soundtracks at your favorite record store, or order direct at these **special DISCOUNT rates!**

IMPORTANT: A large selection of soundtrack albums from fantasy and horror movies (some old and rare, some new) is available for mail order purchase at **discount prices** in each issue of FANGORIA magazine. These are albums that do not appear in this STARLOG selection.

This Discount Coupon Saves You Over 10% Per Record!!!

MAKE YOUR OWN 3-D MOVIES

Use this inexpensive technique to make 3-D movies that reach out and grab your audience.

By MICHAEL RILEY

PHOTO 1

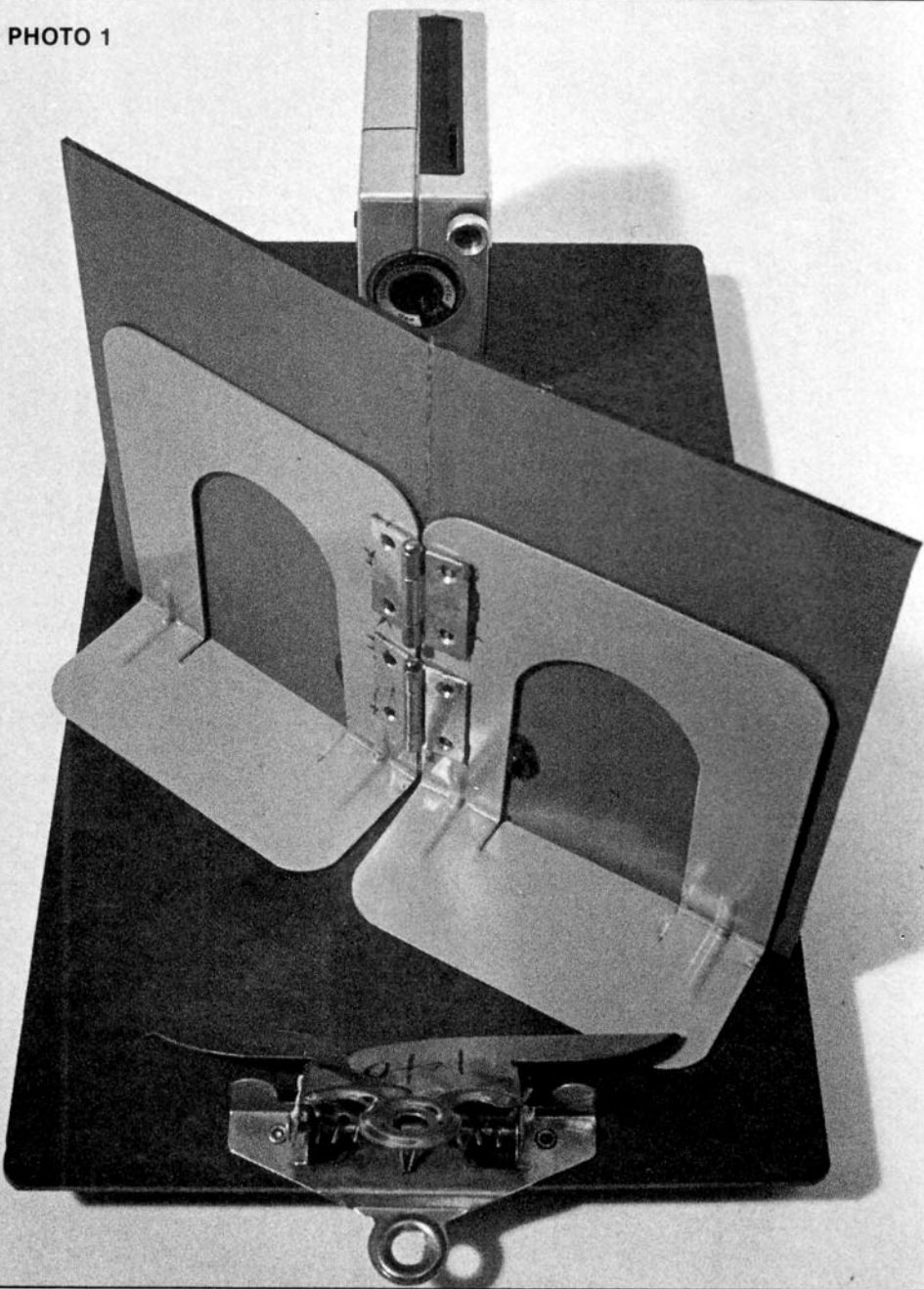

3-D camera system consists of two mirrors, a pair of bookends and a clipboard. Bookend closest to the camera should be glued firmly to the clipboard; the other should be left unglued so it can be repositioned when the clip is raised.

If you've ever tried to find out anything about filming in 3-D, you've probably ended up with the impression that you need expensive equipment, that the equipment is hard to find and that you wouldn't be able to use it unless you had a degree in mathematics. These were some of my thoughts when I began to explore the third dimension, but I stubbornly set out to make my own 3-D equipment, even though I can't hammer a nail into a piece of wood without hitting my thumb. I think the fact that I succeeded surprised me as much as it did anyone.

The apparatus described in this article can be used with any Super-8 or 16mm movie equipment. It is easy to build (you won't even have to use a hammer), easy to use and the results are surprisingly good. I've had people tell me that the effects were far better than any they had seen in the theater. This is partly due to the fact that people can get closer to a small home movie screen than they can to a large theater screen.

Every 10 years or so, a new wave of commercial 3-D films hits the theaters, and people rush to see them. Just as quickly as the fad dies out, a new generation of moviegoers comes along, and another brief wave surges through the country. One explanation for the erratic use of 3-D is that this kind of filming imposes many restrictions on the way the film is made. Certain techniques, such as soft focus, fast cutting and excess depth of field, must be avoided in order not to strain the audience's eyes. Furthermore, with most 3-D systems zoom, wide-angle and telephoto shots are impossible. Additional restrictions are imposed on the movie theater. The seats in the center of the theater offer by far the best viewing.

When light from the projector (which vibrates in all directions) strikes the two filters in the projector assembly, each picture passes through a different filter. The lines of the filters are oriented so that the pictures become coded, one in vertically vibrating light and one in horizontally vibrating light. When the light is reflected back from the screen to the viewer, it meets two more filters in the 3-D glasses. These filters are arranged so that the images become uncoded. For example, the image that consists of vertically vibrating light is the one that should be seen by the right eye. It is screened out by the horizontal lines of the left-eye filter, but the vertical lines of the right-eye filter let it pass through. In a similar manner, the left-eye filter passes only the left-eye image.

Since our camera system takes two pictures from two different angles (corresponding to the two angles from which your eyes would see the scene if you were actually there), and since each eye sees only the picture that was intended for it, the movie appears to be 3-dimensional.

System Construction

Use epoxy to glue metal hinges onto the backs of a set of ordinary bookends. Leave a 1/8-inch gap between them; let paste harden. Draw a line lengthwise down the center of a clipboard and position the bookends on the clipboard as shown in Photo 2. The joint between them should be at a 45° angle to the center line. Glue the bookend that will be closest to camera firmly to the clipboard. The other one should be left unglued so it can be repositioned when the clip is raised.

Glue mirrors to the bookends with epoxy paste, leaving a gap between the two mirrors equal to the thickness of one mirror. (Note: If your camera is a sound camera, the mirrors may have to be glued to the bookends so that they are about two inches higher than the ones pictured in Photo 2. This allows for the extra height of the lens on most sound cameras.) Use large dabs of epoxy so that mirrors can be aligned before the glue hardens.

Alignment can be checked by swinging the movable mirror (the one whose stand is under the clipboard) back until both mirrors form a flat plane. Hold a ruler horizontally up to the mirrors so that its reflection is visible. Then note where the ruler's reflection crosses behind the mirror joint. If the ruler appears broken—that is, if the reflection in one mirror is slightly higher than in the other—then one of the mirrors must be leaning away from you more than the other. Squeeze the bottom edge of that mirror forward until the edge reflection of ruler appears as a straight line.

Attach your movie camera to the clipboard with a 1/4-20 bolt and wing nut. The camera must be positioned so that its lens is directly over the center line and aimed toward the joint between the mirrors. Distance from the camera's focal plane (place where film is when it is being exposed) and the mirror joint should be eight inches.

Adjusting Convergence

The convergence distance is the distance from the mirror joint of the camera assembly to where the mirror's two fields of view converge (see Diagram 3). It should be adjusted correctly in order to avoid eyestrain or double images when the film is viewed. For most of your filming, the convergence distance should be nine feet. It gives the most realistic picture, and it can be used whenever the subject matter is more than five feet from the mirror joint. For close-ups the convergence distance can be temporarily shortened. This is called variable convergence.

To set convergence, first position your camera on the clipboard so that the mirror joint appears in exact center of your viewfinder. Then place an object nine feet from the mirror joint. This object need not be something that you intend to film. It is

DIAGRAM 1

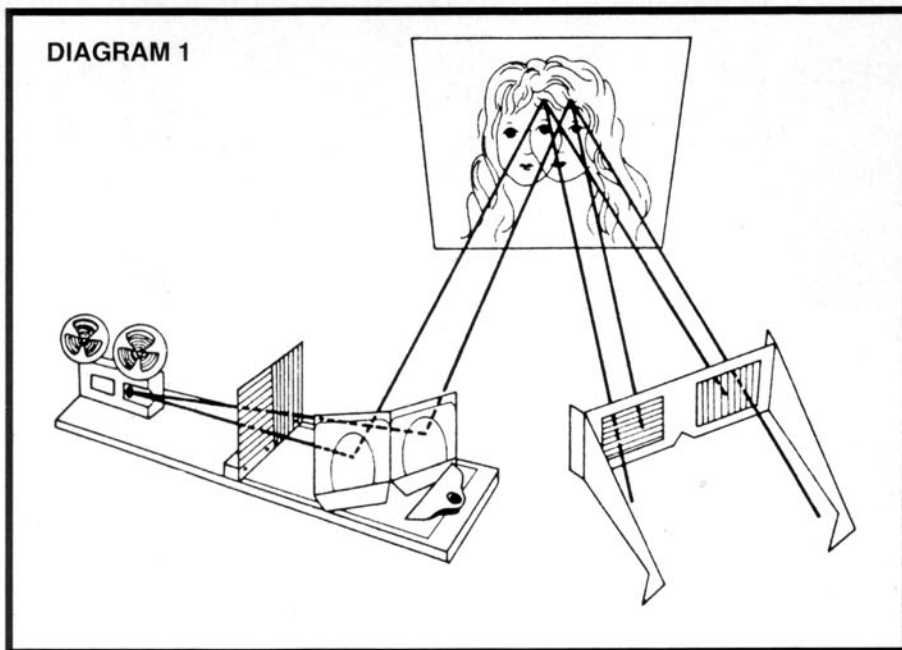

Mirrors of the projection system are arranged so that both pictures converge on one screen. Polarizing filters are arranged in your viewing glasses so that each eye sees only one picture.

DIAGRAM 2

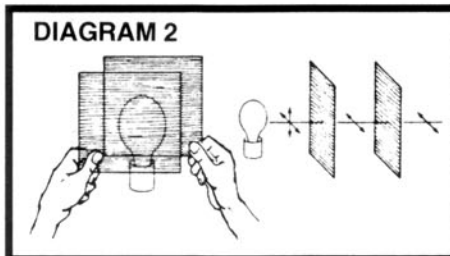

Light passes through two polarizing filters when polarization axes are parallel.

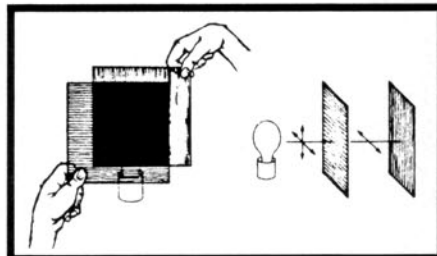

Light is stopped by two filters with perpendicular axes. This is called cross-polarization.

used merely for a reference point to help make the convergence adjustment.

Aim your camera assembly so that the object just touches the left-hand side of the right hand picture in your viewfinder. For fixed convergence adjust the zoom lens, if you have one, to the widest possible angle. Then make your convergence adjustment by changing the position of the No. 2 mirror. For variable convergence, the convergence adjustment can be made either by adjusting the No. 2 mirror or the zoom lens. Either of these methods will cause the object in the right-hand picture to remain in position while the object in the picture on the left will move either closer to or farther from the left side of picture. Make your adjustment so that the object just touches the left side of both pictures.

If your camera is not a reflex, you will have to make your convergence adjustment and then reposition your camera on the clipboard so that the taking lens is aimed directly at the mirror joint. For best results, this should be done as accurately as possible.

DIAGRAM 4

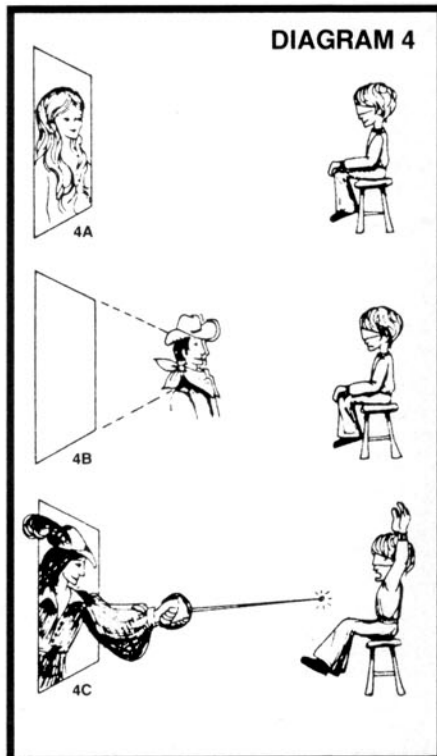

The stereo window. (A) The movie screen appears to be a window through which the action can be viewed. (B) When large objects are placed too far in front of the window, the 3-D illusion is destroyed. (C) This can be solved by having small objects, which aren't cut by the screen edges, appear to come through the window.

PHOTO 2

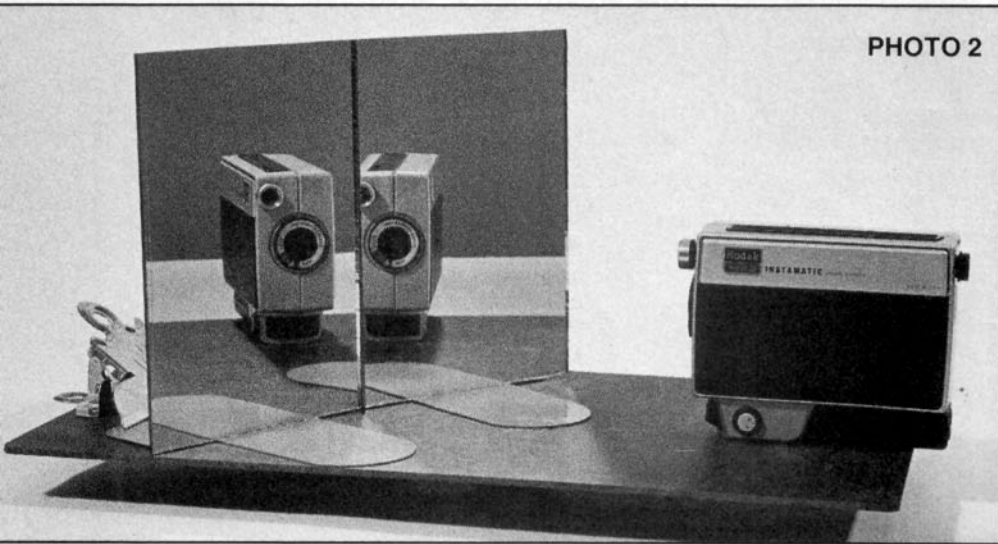

Two mirrors positioned side by side will reflect two slightly different pictures of the same subject in the camera's viewfinder. This double image must be recorded on film to produce a three-dimensional movie.

On the other hand, subjects filmed in 3-D seem much more real. A movie's action is much more exciting if the audience can be made to feel that they can actually reach out and touch the images that seem to float off the screen. For these reasons you might want to try shooting and screening films in three dimensions. If so, then the simple, inexpensive system described on these pages should be just what you're looking for.

How 3-D Works

When you look at things in real life, each of your eyes sees a slightly different picture. In effect, you see things from two slightly different angles. Try holding your hand about two feet in front of your face and then closing first your right eye and then your left eye. As you blink your eyes, notice how your hand seems to shift from side to side against the background. The difference between these two images is one of the things that enables your eyes to judge depth.

In stereo photography two pictures are taken of the same scene. These pictures are usually taken from two points that are 2½ inches apart, which is the same as the distance between your eyes. The two pictures are then presented so that one eye sees one picture and the other eye sees the other picture. This allows each eye to see the scene from the same angle that it would if it were looking at the real thing.

The first requirement for making 3-D movies is that two pictures must be taken of the subject from two slightly different angles. The easiest way to meet this requirement is by using a mirror arrangement as shown in Photo 1. As you look through the viewfinder of this setup, you'll see two pictures of the same subject side by side. The picture on the left side of the viewfinder is the reflection of one mirror, and the picture on the right is the reflection in the other mirror. The image that is

recorded on the film is the same as the one seen through the viewfinder.

When the film is projected, the two mirrors that were used in the camera assembly are placed in front of the projector. They are positioned so that each mirror reflects one of the two pictures and each picture is projected onto the same screen (see Diagram 1).

The second requirement that must be met for stereo movies is that each eye must see only one of the two pictures. This is accomplished by placing polarizing filters in front of the mirrors and in the 3-D glasses of the spectators. Polarizing filters act as if they had microscopic lines in them which screen out any light vibrating in the opposite direction of the lines but allow light vibrating in the same direction to pass through (see Diagram 2).

Filming in 3-D

Before shooting each roll of film, place an object nine feet from the mirror joint of your camera assembly. Center an object in either one of the pictures in your viewfinder and shoot a few feet of film. This part of the film will be used later as a test pattern to line up the projected images.

Filming in 3-D is not exactly the same as filming in 2-D. The first thing you'll have to get used to is aiming the camera. When you look straight ahead into the viewfinder, the mirrors will show you a picture of something that is off to your left. If you're not using a tripod, you should practice aiming the camera before shooting any film.

In 3-D, you have to avoid using a lot of fast cuts. You should especially avoid cutting back and forth between a distant subject and a close-up one. This is because it takes time for an audience to adjust to sharp changes in depth.

You should also pay attention to the amount of depth in each scene. Subject

matter that is shallow to begin with will also look shallow on the screen. When an object comes closer to the camera than about five feet, you should use the recommendations for super depth.

Super Depth

It seems that almost every 3-D movie has at least one scene where bats, arrows, landslides, etc., seem to come right off the screen and out into the audience. The secret for creating this type of illusion is to use a small object and bring it close to the camera without letting it touch the edges of either picture in the viewfinder. This is because the movie screen appears to be a window through which the action can be

DIAGRAM 5

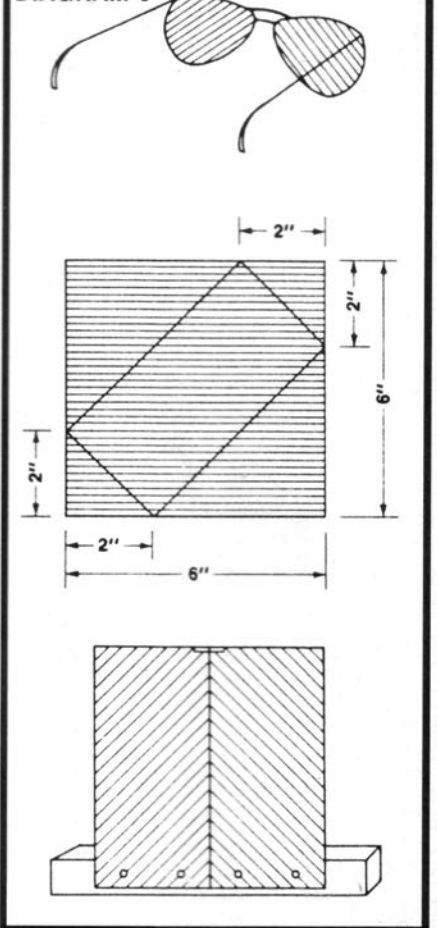

Commercially made 3-D glasses have a diagonal orientation. They require that filters in the projection system be specially cut.

viewed (see Diagram 4). Your mind will accept the illusion of a small object coming through the window, but it won't believe that a large object such as a car can come through a 2½ x 3½-foot opening.

Another aid to creating this type of illusion is to have the background the same distance from the camera as the convergence distance (usually nine feet). This establishes reference points so your eyes can compare the near object with the background. When these rules are follow-

ed, each member of the audience will see the object coming directly toward him. If the object is small enough, it can be moved to within about four inches of the mirror joint without touching the edges of either of the two pictures in the viewfinder. A member of the audience will then see the object as being about 12 inches in front of his or her face.

Projection Equipment

The movie screen can be any 2½ x 3½-foot smooth, flat surface. The screen surface must be covered with aluminum paint to insure that light from the projector remains polarized.

Aluminum paint does not make the best 3-D screen surface, but it will work and it is cheap. Standard matte white or glass beaded screens will *not* work—they depolarize the light, allowing your eyes to see both images. If you use a commercial screen it must be a silver screen. If you already own or have access to an aluminized video projection screen, you will find that it will work very nicely for 3-D. Eventually, if you get the 3-D bug, you should buy a commercial silver screen. They are available from nearly every major manufacturer.

The 3-D glasses shown in Diagram 1 were made from three pieces of thin cardboard that were stapled together. The side pieces are 2 x 6 inches, and the front piece is 2 x 6¾ inches. They bow in to fit all sizes and are big enough to fit over prescription glasses.

A 1 x 2 x 10-inch wood block can be used for the filter stand. Attach two of the 6 x 6-inch polarizing filters side by side to the stand with thumbtacks (see Photo 3). The other filters can be cut up into smaller squares and taped to the inside of the glasses.

Your polarizing filters will probably not have any markings on them to indicate their axis of polarization. However, you will still be able to align them properly in your glasses and filter stand. To determine if two filters are oriented perpendicularly to each other, place them together and hold them up to a light (see Diagram 2). If they are perpendicular, then the area where they overlap will appear black or dark blue. If not, they can be made perpendicular by rotating one of them. Filters will be properly aligned when: 1) two large filters on the filter stand are oriented perpendicularly to each other; 2) all left-eye filters in 3-D glasses are oriented perpendicularly to filter on left side of filter stand (when sighting from projector to filters); and 3) all right-eye filters are oriented perpendicularly to the filter on the right side of the stand.

Some polarizing filters have a film side and a base side. For best results the film side of the projector filters should be facing the mirrors, and the film side of the filters in glasses should be facing the screen. To determine the film side of two

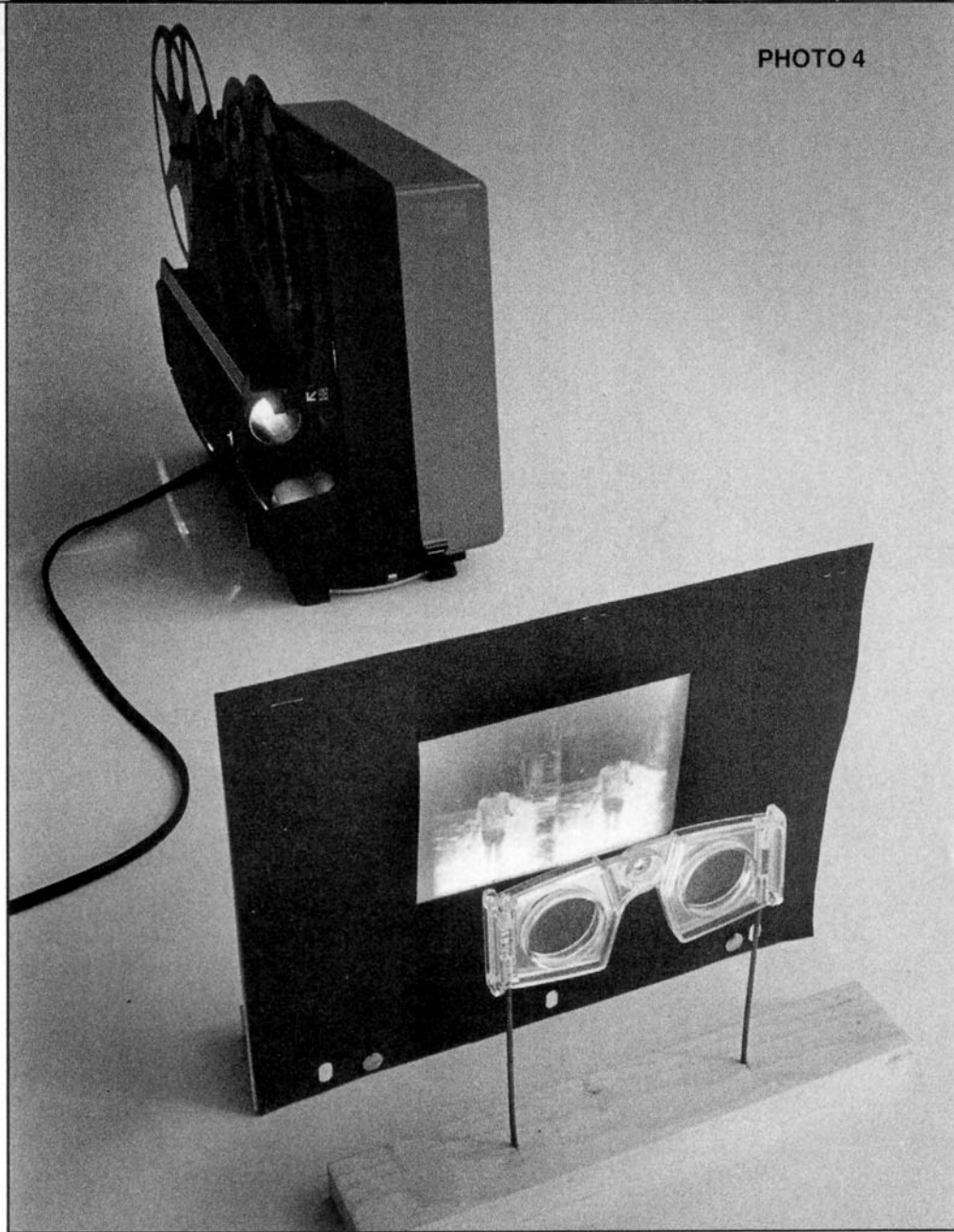

A rear-screen previewer can be constructed for single viewers and editing purposes. Plastic viewer can be adapted from parts available from Reel 3-D Enterprises (see source list on page 21).

filters, rotate one against the other until their axes are crossed. If the film sides of your filters are face to face, then they will cancel out evenly, and only a small amount of dark blue light will pass through. If, however, one or both filters is facing away from the other, then some patches of white light will be visible.

Projection Set-up

Draw a line down the center of 10-inch x four-foot board. Remove the camera from the mirror assembly and attach the assembly to one end of the board, as shown in Photo 3. The center line of the mirror assembly should be directly over the center line of the board.

Place the filter stand on your board so that the joint between filters is directly over the center line and is about six inches from the mirror joint. Filters should be at right angles to the center line.

Place your projector on the board so that the lens is directly over the center line and about two feet from the mirrors. The lens should be aimed directly at the mirror joint. If the projector's beam of light is too wide, not all the light will strike the mirrors, and some of it will spill over the edge. In this case, you will have to move the projector closer.

The best picture results when your projector, filters and mirrors are perfectly aligned. I've found an easy way to insure this alignment. First, move the filter stand off to one side and place a white piece of cardboard flat up against the mirrors. Change your projector's focus so that the projected image is visible on the card. This image will contain two side-by-side pictures. Sight from the projector to the card and aim the projector so that the line between the two pictures falls directly over the mirror joint. When the filter

assembly is replaced, the joint between the filters will cause a shadow to fall on the cardboard. This shadow should also fall directly over the mirror joint.

Center the projected image on your screen by moving the entire assembly rather than just the projector. To raise the image, tilt the assembly by placing blocks under the board edge.

Run your film through until you get to the test pattern. By adjusting the position of the No. 2 mirror, you can move one of the images on the screen from side to side, while the other image remains still. The No. 2 mirror should be positioned so that both images of the test pattern object are exactly on top of each other and appear as one image.

So far, if everything has been done correctly, the two images should already be

camera alignment didn't change too much during filming, you should be able to do this without having to adjust the projector mirrors each time you come to a test pattern. The basic rule to follow is: *The left-eye image on the screen should never be more than three inches to the left of the right-eye image.* Your eyes are only 2½ inches apart, so when the left-eye image is more than 2½ inches to the left of the right-eye image, your eyes would be forced to diverge (the opposite of going cross-eyed) more than parallel. This is something they are able to do, but only up to a point. Too much divergence can cause eye-strain. Before showing the film to an audience, align the images on the screen with one of the test patterns, and then run through the rest of the film without wearing your 3-D glasses. You will find that some objects

appear as single images, while others appear as double images. Pay special attention to objects that are farthest from the camera. Each time you find a pair of images that are displaced more than three inches, check with your 3-D glasses to see whether the left-eye image is the one that is the farthest to the left. If it is, then readjust the No. 2 mirror to bring the images back to the three-inch limit. Your final adjustment is the one that should be used to project the show.

Large Audiences

For large audiences you can avoid the trouble of making your own 3-D glasses by ordering ready-made glasses. Because professionally made glasses have a diagonal orientation instead of a horizontal or vertical direction, the filters will have to be recut as shown Diagram 5. Be careful to cut them so that when they are arranged side by side on the filter stand: 1) filter on the right (when looking from projector to filters) is perpendicular to left-eye filter in 3-D glasses; 2) filter on the left is perpendicular to the right-eye filter in the glasses; and 3) the film side of both filters is facing the mirrors.

Whenever a screen wider than 2½ feet is used with this 3-D system, there is a chance that far points on the screen will be displaced more than three inches. To avoid this you can use the system for alignment that is described above in the "Editing" section, or you can make a special test pattern at the beginning of each roll. The following table shows what camera-to-object distance to use.

TEST PATTERN DISTANCE FOR LARGE SCREENS

Screen Width	0-2½'	2½-3'	3-4'	4-5'	5-6'
Distance From Camera to Object	9'	10'	17'	21'	26'

PHOTO 3

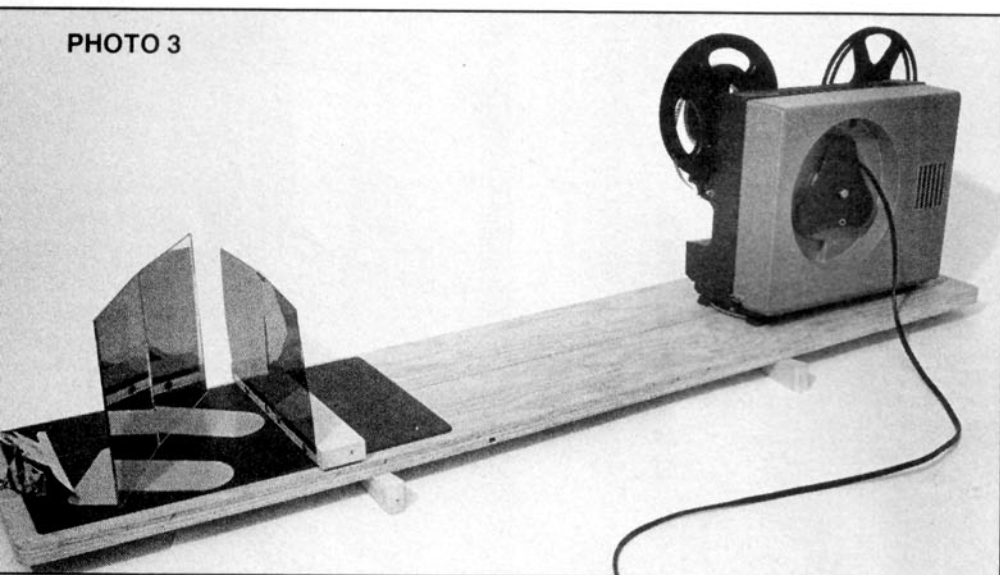

The projector system uses the same mirror assembly that was made for the camera. Polaroid filters have been placed on a stand between the projector and the mirrors.

aligned vertically as well as horizontally. That is, neither should be higher than the other. If this isn't the case, the best way to align them at this stage is to place a pair of small wedges underneath the projector legs in order to tilt the projector slightly to one side. This will lower one image while raising the other. Unfortunately, changing the vertical alignment will throw all your other alignments off, and you will have to go back to the beginning of this section and start over.

When your test pattern is aligned, you are ready for the moment of truth. Put on your 3-D glasses and see how the rest of your film looks. You'll find that by moving closer to the screen, you'll get a shallower picture, and by moving away, you'll get a deeper picture. As soon as you've found the best place to put the seats for your audience, you are ready for the show.

Editing

You may wish to splice several rolls of film together to make a complete show. If

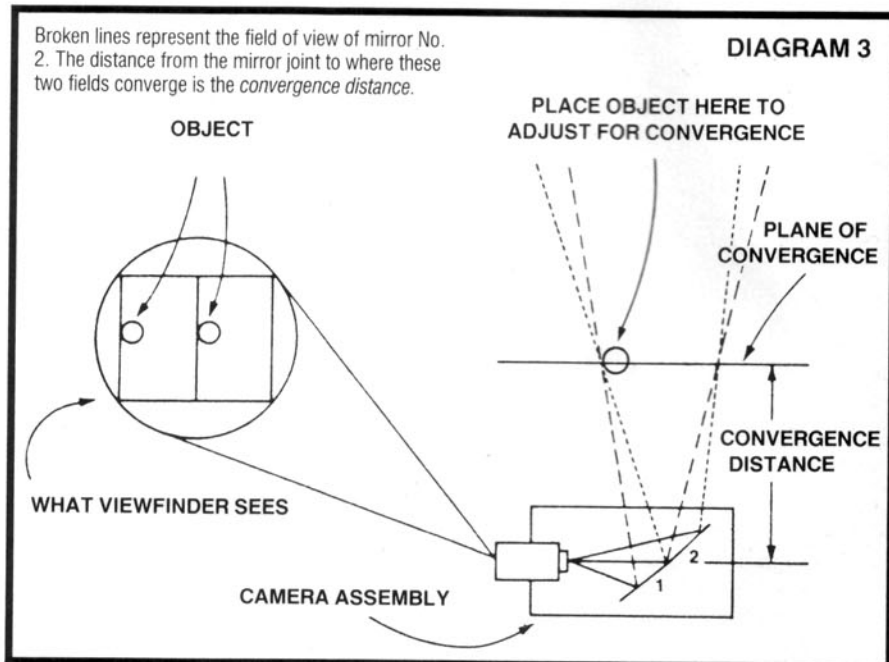

DIAGRAM 3

Broken lines represent the field of view of mirror No. 2. The distance from the mirror joint to where these two fields converge is the convergence distance.

Applications

The characteristic of 3-D films that has been exploited most often is their capability to make subjects seem more real. This feature is especially valuable in horror movies. The illusion of being in the same room with a ghost or monster makes scary films even more frightening. Not only could you almost reach out and touch the ghoul—it could almost pop out of the screen and get you!

But 3-D can also subtly enhance its subject. Images from nature take on new visual fascination when the textures, leaves, branches and water reflections appear deep and real. The perception of depth is a dramatic, important visual element that can be used to splendid effect in home motion pictures.

3-D offers new challenges in composition for the serious cinematic artist. Instead of arranging subjects on the screen like a painter would—in two dimensions—the director must think like a sculptor. The added dimension invites the audience into the picture. Instead of seeing the movie as objective observers, viewers are able to mentally explore the space of each scene. With this dramatic cinematic effect your 3-D movies are bound to be spellbinding eye-openers.

PARTS LIST

Legal-size clipboard
 Pair of plain metal bookends
 4-foot x 10-inch board
 1/2-inch 1/4-20 bolt
 1/4-20 wing nut
 1/4-inch washers
 Pair of small metal hinges
 Package of epoxy glue
 Small can of aluminum paint
 2 1/2 x 3 1/2-inch piece of smooth, flat cardboard or Masonite for movie screen

Polaroid filters and viewers are available in a special experimenter's package, which has been assembled for readers of this magazine. Twelve pairs of polaroid viewers and enough polarizing material for your projector are available from John Brumage of LeaVision, P.O. Box 3D, Lydenhurst, NY 11757 for \$15.00 postpaid. Sheet polarizing material is very thin, requiring a cardboard frame for support.

Two 5 x 7 x 1/16-inch mirrors
Note: Front surface mirrors have better optical properties than regular mirrors because they have the reflective surface in front of the glass instead of behind it. Thus light that's reflected doesn't have to be disturbed by passing through the glass. These mirrors can be ordered from Edmund Scientific Company, 101 E. Gloucester Pike, Barrington, New Jersey 08007.

ZOOMIN' OUT ATCHA! IN 3-D

SPECIAL
3-D VIEWERS
INCLUDED IN
EACH BOOK.

The Newest and Most Amazing STARLOG Photo Guidebook

STARLOG's special effects wizard, David Hutchison, has compiled a spectacular new addition to the famous STARLOG Photo Guidebook series of quality paperbacks. In one deluxe volume is a collection of the best articles on 3-D techniques, movies, comics, and much more!!!

- Complete index of 3-D comics & magazines!
- Complete guide to 3-D movies (credits, plots, etc.).
- How to make your own 3-D photos with any camera!
- Sources of 3-D equipment and supplies!
- 3-D books section!
- List of 3-D clubs worldwide!
- NASA/Mars 3-D photos!
- How 3-D TV works!
- History of 3-D!
- Movie special effects in 3-D!

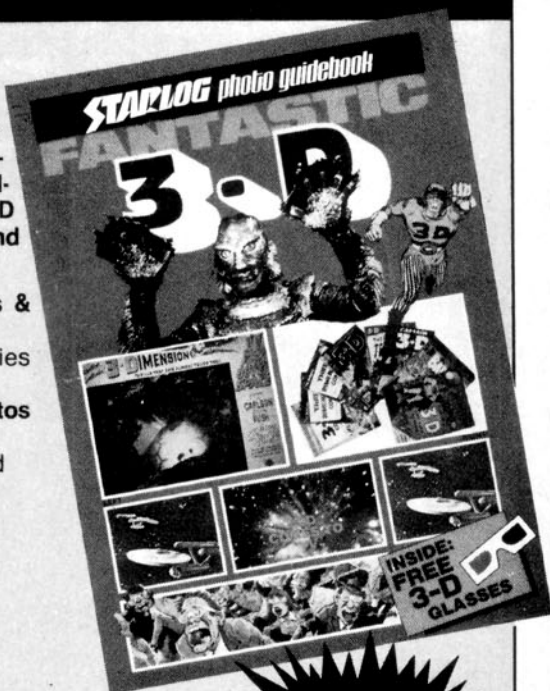

This exciting 96-page book includes articles by 3-D experts on state-of-the-art technology and is illustrated with hundreds of photos and special art. "Fantastic 3-D" is the one authoritative volume covering every aspect of this incredible field.

ORDER YOUR COPY TODAY!

*Also available at Waldenbooks and other SF, comics and movie book stores.

Please rush _____ copy(ies) of "FANTASTIC 3-D" at \$11.95 each, plus postage.

ADD POSTAGE:

_____ 3rd Class \$1.55 ea.
 _____ 1st Class \$1.75 ea.
 _____ Foreign Air \$2.50 ea.

Total enclosed: \$ _____

NYS residents must add sales tax. Please allow 3-6 weeks for delivery.

Send cash, check or money order to:

STARLOG 3-D
 475 Park Ave. South
 New York, NY 10016

NAME _____

ADDRESS _____

CITY _____

STATE _____ ZIP _____

Searching for

3-D



Filmmaking in 3-D is still an experimental format.

If Michael Riley's article on the basics of 3-D movie making has whetted your appetite for more, you may be pleased to learn that a few companies actually manufactured 3-D movie outfits for amateur enthusiasts. The most common 3-D movie outfits are (or were) the Bolex and the Elgeet for 16mm users, and the Elmo for Super-8.

Unfortunately, all of these 3-D movie systems are *attachments*—devices meant to adapt ordinary 16mm and Super-8 cameras to 3-D filmmaking. No manufacturer has ever produced a 3-D movie camera for the amateur market, nor has a standardized format ever been established for Super-8 and 16mm 3-D formats. This is in marked contrast to the situation of 3-D still photographers, who have comparatively easy access to 3-D equipment and established standards. Several manufacturers in the U.S. and Europe

designed and manufactured a variety of 3-D cameras, which are readily available in used camera shops everywhere.

The entire process of 3-D *still* photography has been thoroughly systematized. You just pop a roll of 35mm Kodachrome or whatever, into a Stereo Realist, Kodak Stereo, etc. and shoot away. Send the film out for processing and stereo mounting, and few days later you can project your 3-D slides in any several brands of 3-D projectors. No such luck for would-be 3-D movie buffs—it is all strictly an experimental, make-do operation, particularly for Super-8 users, as we shall see.

Dedicated 3-D Bolex

The Bolex Stereo System, originally marketed in the early 1950s, is probably the most well-known 16mm 3-D movie attachment. There are essentially two parts to the system. There is a special camera lens that fits the non-reflex Bolex H16, exclusively, and there is a special projection lens which replaces the normal lens on many 16mm projectors. Bolex supplied a number of adapter sleeves for this purpose.

The basic component of the Bolex system is the precision-engineered camera lens, which is screwed into the turret of the H16 in place of the ordinary lens. At the back of the stereo lens attachment are twin Yvar 12.5mm f/2.8 lenses separated by an optical axis of only 3.5mm. A prism system widens this axis to an effective separation of 64mm—normal interocular spacing for 3-D photography. The lenses are fixed focus, set at the hyperfocal distance of 10 feet; the aperture is continuously variable down to f/16.

The stereo window is set at approximately 10 feet. As you remember from Michael Riley's article, a 10-foot window means that when your 3-D movie is pro-

jected, anything closer than 10 feet from the camera will appear to hang in space in front of the screen, while objects beyond 10 feet will appear to be placed behind the projection screen. Bolex recommended keeping objects at least five feet away from the camera. For close-up 3-D effects, a special close-up attachment permitted shooting at distances from 18 inches to four feet. Special parallax correcting scales and viewfinder masks were supplied to maintain image placement accuracy with the close-up system.

The Bolex 3-D lens attachment places the left and right eye images side by side—splitting the normal 16mm frame. For projection a special duplex-lens objective replaces your standard 16mm projector lens. Inside the lens barrel are twin 20mm, f/1.6 Petzval lenses with parallel optical axes spaced 5.6mm apart. Standard orientation polarizers are built into the objective, so that your 3-D movies can be viewed with commonly available 3-D polarizing glasses.

Other accessories in the Bolex Stereo System included a special offset bracket for the camera's viewfinder and the finder aperture mask which masks down the standard 16mm frame to the Bolex stereo format for accurate composition.

The complete system, including camera lens, offset bracket, viewfinder mask, projection lens, two pairs of viewing glasses and a silver screen, sold for a hefty \$397.50 back in 1953.

Universal Elgeet 3-D

The only major competitor to the Bolex Stereo System was the Elgeet Cine-Stereo System. The system operated in a manner very similar to the Bolex system, but the Elgeet had two big advantages: it was cheaper and it would fit almost any movie camera.

The Elgeet Stereo Lens was designed to

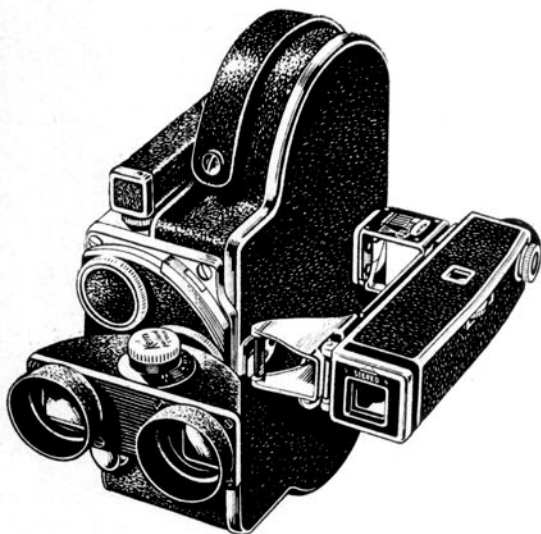

The Bolex camera with normal 3-D attachment fitted to the front of the camera.

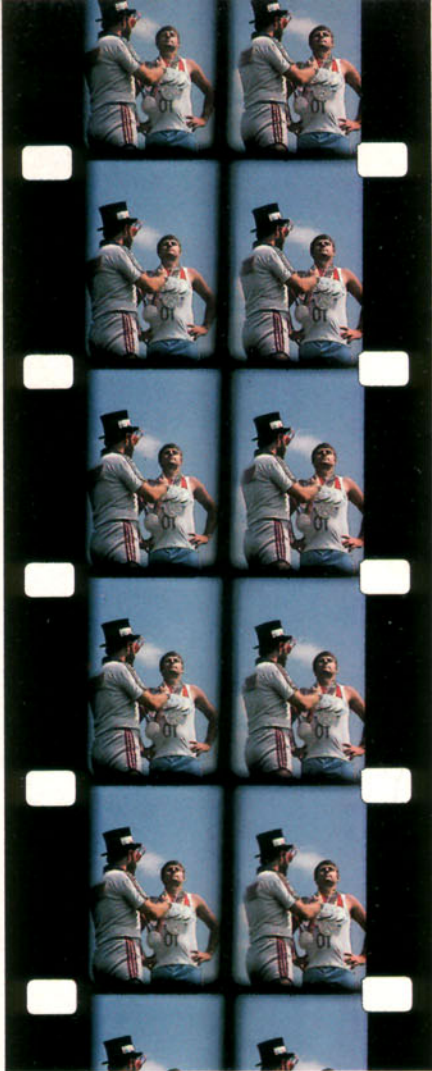

Opposite top: The Spondon 3-D attachment. **Above:** Bolex 3-D positions the left and right images side by side. **Below left:** Spondon 3-D creates a red/green anaglyph 3-D image using the entire Super-8 frame. **Below right:** Widescreen 3-D Super-8 is possible with attachments that split the frame and rotate the image.



fit all 16mm standard C-mount cameras. Twin 13mm, f/2.8 fixed-focus lenses at the rear of the attachment were spread to standard stereo interocular with rhomboid prisms were fully color-corrected, hard coated and were supplied mask corrected the field of view in the finder of the stereo format for accurate composition.

The projection lens was also very similar to Bolex's design with its twin f/1.6 coated lenses and built-in polarizing filters. A series of adapters permitted

are discovered at garage sales. But neither system is common or readily available. Professional dealers of used equipment, particularly those that specialize in 3-D and/or used movie equipment may be able to find one or the other for you. However, you may find that their retail value has appreciated a good bit over the years.

Super-8 In 3-D

Amazingly, only one 3-D attachment



David Starkman of Reel 3-D Enterprises demonstrates the Bolex 3-D Close-up System.

mounting the lens in a variety of different 16mm projectors.

The complete system, including camera lens, finder mask, projection lens, eight pairs of viewing glasses and a silver screen sold for \$249.00—considerably cheaper than Bolex's system.

Both systems work well and are easy to use. The biggest disadvantage is the format: the standard 16mm frame is split vertically to place the left and right eye images side by side. This results in a very tall, narrower format which may be ideal for taking pictures of trees, individuals and tall buildings, but can prove frustrating to those of us who are used to working in the standard slightly-wider-than-high image format.

From time to time, both of these 3-D systems show up in used camera shops or

was ever produced for Super-8 users. The Elmo Super-8 Stereo-Movie Unit ESM-1 was created in the early 1970s for use on certain Elmo cameras and projectors, specifically: Elmo camera models 8S-40, 8S-60, the Super 104, 106, 108, 110 and 110R.

It was the only system made specifically for Super-8, and the only one of all these commercial systems which produces a 3-D image in a horizontal format. The attachment was available directly from Elmo in Japan, but was never imported by the U.S. distributor. Elmo achieved the ultimate in economy by using the same attachment for both the camera and, with the addition of polarizers and bracket, the projector.

This single all-purpose 3-D attachment consists of a series of five front-surface

mirrors which split the movie frame vertically for the left and right eye images, placing them side by side. However, the side-by-side images are rotated 90 degrees in a foot-to-foot orientation. The result is a very pleasing wider-than-high format. The front-surface mirrors are not protected from dust and require frequent attention with a soft camel's hair blower brush.

Two brackets are supplied, which will mount the ESM-1 to the front of specific models of Elmo cameras and projectors, respectively. The 3-D attachment is quite large, measuring nine inches wide, by six inches high and three inches deep. Once mounted, camera operation is normal, except that the zoom lens is restricted to a range of 10mm to 18mm. Convergence is variable, but the control is not calibrated and requires some experimentation and practice to achieve predictable results.

A viewfinder attachment rotates the two images from the side-by-side vertical orientation so that one image may be seen from a normal horizontal viewpoint. For normal shooting the inverted image is ignored.

A special bracket attaches the ESM-1 to an Elmo projector: specifically all SP and ST series projectors; the FP-A, FP-C, FP-E and FP-H projectors; and the GP-E, GP Deluxe and GP Hi-Deluxe models. Elmo projectors have a threaded hole for attaching various accessories, including the Stereo Projection Bracket, which mounts directly to the projector and contains its own polarizing filters. The ESM-1 unit is removed from the camera and mounted in this projection bracket. Convergence is adjusted using the same knob control that was used when filming. Vertical alignment is achieved by moving the entire unit in the bracket mount.

Your film should be edited with a splicer that makes a cut between the frame lines,



Filmmaker John Hart shoots Super-8 3-D with a custom designed mirror box attachment. Image format is the same as with the Elmo 3-D attachment.

instead of through the center of the frame. David Starkman of Reel 3-D Enterprises recommends a Hervic/Minnette, as one popular, easy-to-use model that does the job.

The Elmo projection bracket places the polarizers between the projection lens and the mirror box unit. The polarizers are *not* oriented in the standard position, which means the polarizers in standard glasses will have to be re-oriented. Alternatively, Starkman recommends replacing the Elmo polarizers with large standard-orientation polarizers placed in front of the mirror unit. "By making the polarizers the *last* surface for the images to pass through," Starkman explains, "ghosting is reduced, and standard 3-D glasses may be used.

"The final result," Starkman adds, "is a very acceptable Super-8 image that is almost twice as wide as it is high, with the same film and processing cost as standard Super-8. Editing is the same, although 3-D viewing cannot be done on a table-top film editor. To edit out scenes with 3-D convergence problems, one has to first view the movie projected in 3-D, and make notes on what scenes to edit later."

Do It Yourself 3-D

It is unfortunate that the Elmo unit is not more generally available. Comparatively few units found their way into this country, largely through the efforts of enthusiastic 3-D buffs and members of the Widescreen Association. For this reason, most 3-D filmmakers working in Super-8 have cobbled together 3-D rigs of their own design.

It is possible to adapt attachments that were designed for 3-D still photography to Super-8 cameras. Quite a few varieties were manufactured over the last couple of decades. Most are readily available through used equipment dealers and some are still available as new equipment from manufacturers.

These devices are usually referred to as 3-D "beam-splitters" and are designed to be mounted to the front of a standard 35mm camera lens via the filter threads on the front of the lens barrel. They are marketed under various trademarks including: Stitz, Pentax (still manufactured),

and Stereo-Tach, Tri-Delta (available only as used equipment).

Experimenters have reported good results with the Tri-Delta Prism Stereo unit. The unit was not designed for Super-8 use and there is no convergence adjustment, but the attachment produces a wide horizontal image similar to the Elmo unit. The Tri-Delta Prism Stereo Attachment can often be found at used camera and equipment trade shows.

Some years ago, Super8 Sound electronically linked a pair of Nizo Super-8 cameras for filmmaker Lenny Lipton. This double system 3-D unit requires a pair of interlocked projectors as well. The system can achieve brilliant high quality results, but only at enormous costs.

Anaglyph Alternative

Half a decade ago, before the video boom many major motion picture companies released abridged versions of their theatrical features in Super-8. Home movie buffs had access to everything from *Birth of a Nation* to *Star Wars* with some titles boasting stereophonic sound and widescreen CinemaScope.

For consumer convenience, a few black and white 3-D films were released in the red/green anaglyph form. Requiring only red and green glasses (similar to the type used for 3-D comic books) these films could be shown anywhere, with a standard projector and on an ordinary screen. Among the titles released were: *It Came From Outer Space*, *The Creature from the Black Lagoon*, *The Mad Magician* and a couple of Three Stooges shorts. Red/Green anaglyph is not the best system for 3-D, but it is an inexpensive way to get started in 3-D.

The red/green 3-D process dates back to the middle of the 19th century, but survives today as the medium of choice for 3-D comic books and 3-D book and magazine illustrations (as in my book *FANTASTIC 3-D*). The quality of the anaglyph 3-D image does not begin to compare with the more sophisticated polaroid projection systems described earlier in this article.

However, there are some *big* advantages. You can use the camera and projector that you currently own. No polaroid filters are required. You will not have to spend hundreds of dollars searching out and buying antique 3-D attachments from the 1950s. And, you can get big full frame images without resorting to double system 3-D—two cameras, two projectors, sync block, etc. Anaglyph 3-D presents a minimum fuss, trouble and expense to the 3-D experimenter.

Recognizing this, a British firm has just introduced a new 3-D attachment which allows you to make your own anaglyph movies in Super-8 or 16mm. The Spondon anaglyph attachment uses two mirrors to superimpose the left and right eye images within a single frame. One is a

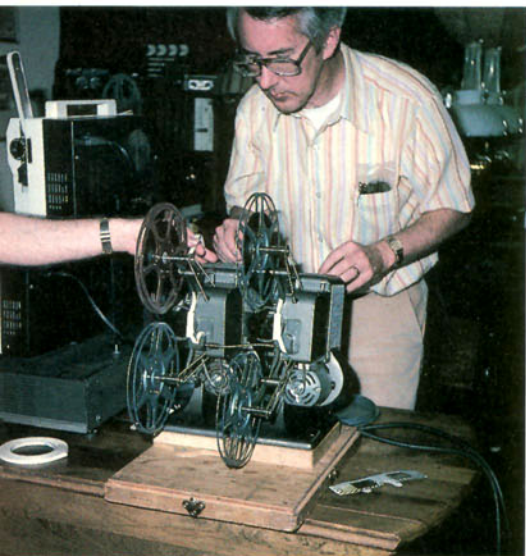

John Hart prepares to screen a dual 8mm 3-D film with a pair of mechanically interlocked Kodak projectors—a custom-built rig.

From A,B,C, to MTV

By REX PIANO

Vinyl to Video

So, you want to make a rock video. You've got a camera, your friend's in a band, and they've got a song recorded. Great! Now what? Well, sit down, turn on some music, get a drink and read this. Having produced a dozen or so videos myself, I'll tell you step by step how to make your own—*cheap!*

Before I start, let me make one thing clear; if you want your video to ever find its way to television or MTV, it must be up to professional standards and that means that the minimum you are going to spend is around \$3,500, to make it look good—unless you get everything for free. If you want to make a rock video just for fun, or to try your hand at it; then it will probably cost you just expenses.

Now that you are totally depressed at the reality of what it actually costs, keep reading, it gets better.

Your first step is to listen to the song, and believe me that can be torture. Before the video is done you will have listened to the same song over and over a couple of hundred times, and if you don't like the music, then it's even worse. When you listen to the music, write down any ideas the lyrics or the tune evoke; you'll use these ideas later when you are storyboarding the video. After listening to the song a few times, the next step is to transcribe the lyrics and break them up into seg-

ments: Phrase one, Chorus, Phrase two, etc. This can be a real pain, especially if you are taking them from a record instead of a cassette deck with a pause lever.

After all of the lyrics are transcribed, lay the song out on paper. This will become the blueprint of your video, and should include all the timings, from the very first note of the song to the last. Every section has to be timed: choruses, any solos, etc. These times will later be used when you storyboard the show.

Storyboarding

Now that you've got the song broken down in terms of lyrics, chorus, and solos, all with individual timings, you can start directing on paper by making storyboard sheets. Use regular 8½" x 11" paper with four horizontal frames running down the center of the page (I've made my own by outlining credit cards, their shape is almost 1:85 scale—roughly the aspect ratio of a video frame.) On the left side of the column will be the timings of each shot along with the lyrics that go with the shot. On the right side of the column should be all camera and action directions.

When you are designing the video keep these things in mind:

1) **Make sure to cover actions in close-ups!** These include guitar solos, drum solos, even drum hits. These will save you

in the editing because you can always cut to something on the beat.

2) **Get a lot of cut-aways!** Shots of the singer smiling, guitar and bass players swinging their instruments, the drummer's face, anything that has to do with the band. This is especially important if you are shooting a performance piece, because you want to show a particular side of the band's personality and this is conveyed by their on-camera actions.

3) **Cover the same lyrics and solos with lots of angles!** Make sure when you shoot that you have plenty of film, because you're going to have to shoot the same actions over and over from different angles and possibly at different locations. This will allow you show the singer in different settings without disrupting the



Choker close-up of lead singer John Pisciotta.

song, missing a lyric cutting to another performer.

4) **Move the camera when you film!** All music has a beat, and the camera should enhance this beat through visual motion. Do not be afraid to turn the camera sideways, or to move around the band as they perform. It makes a more interesting shot, and also helps in the editing.

After you've finished all of this preparation—the script is written and the storyboards are complete—a script breakdown is next. You do this by going over every shot and scene, then pull out all the elements that are necessary to the shoot and list them, for example: location, props, day or night, etc.

Before you shoot, you should consider how you want the video to look. If you intend to "post it" (a term which means to finish or edit, derived from "post-production") on video tape, then you should shoot on negative film stock as this allows you the most latitude when color correcting. Each film stock looks slightly different when transferred, and the choice should be made based on the aesthetic qualities desired. The choice of film stock could also vary depending on the conditions of the shoot. If your story calls for something to look like Super-8, then shoot it on Super-8, and so on. Once you have everything under control, then comes the fun part: shooting the video.

Video Transfer

But wait, if the song is still on a record or a cassette, how do you play that and film at the same time so the band is in sync? Here comes the tricky part. There are several ways to do this. The cheapest way is to just play back the music from a cassette deck and shoot the band lip-syncing to it. But this is also the most difficult way to sync up the exposed footage, and you may not get more than four words in sync with each take. However, it can be done this way, although I don't recommend it. The most effective way to sync up audio and video is as follows. This pertains only if you are planning to edit on 3/4-inch and one-inch video tape (this is where it starts to get expensive). If you are going to edit on film, using a flat-bed, I'll go over

that later.

To finish on video tape, you must understand the process. Once shooting is completed, have the exposed film developed only. Then transfer that to both one-inch and 3/4-inch video tape with identical time code numbers on the address track. When you make the 3/4-inch specify that you want the time code numbers in a window with V.R.O. (visual read out). These numbers will later allow you to match the off-line picture to the 1-inch picture. The off-line is where you do the actual cutting of picture to sound and make your "workprint" or "frozen cut." The next step is the on-line edit session. At this point you match, using the time code numbers, your original picture to your "workprint." At the end of the on-line session, the rock video will be complete.

However, before you get to this point you still have to have the music transferred. You should take the cleanest form of the recorded song, preferably from the original mastered recording and have it transferred to 1/2-inch four-track audio tape, with the stereo music on tracks one & two, Nagra-tone on track three, and time code on track four, at the same time, a 1/4-inch tape should be made for playback during the shoot. While the lab is doing these transfers, they should also transfer the music with the same time code to one-inch and 3/4-inch video tape. These two tapes will become your edit masters.

When you go to shoot, your sound man will need two Nagras; one for playback, the other for recording a scratch track; a line connects both Nagras—thereby recording the song onto the scratch track. A set mic will be needed to record the slate claps. You will also need a P.A. system, so the band can hear the music being played. If you have some extra money, you can rent "ear wigs," these are tiny radio transmitted speakers that the musicians can put in their ears and listen to the music, cutting the volume of set noise drastically.

Shooting begins like any other shoot; start rolling sound, film the slate clapping, then roll the song on playback. Shoot all of your storyboards, plus whatever else you can squeeze in and then it's a wrap!

Editing on Video

Now comes the tough-but-fun part—Editing!

As mentioned before, have the film developed and transferred. Have all of the sound transferred to another 3/4-inch tape, and then sync up the sound to the picture. Once all of the sound has been synched you are ready to start editing.

At this point you will take the 3/4-inch master tape, that has just the song recorded on it, and make insert edits using the scratch track to sync up to the music. Although this system is very complex in that it needs a lot of preparation, it saves you the most time in editing. When the

show is completed, you simply take the 3/4-inch master edited tape into the on-line session.

For the on-line session the elements you will need are the original one-inch video, the one-inch master tape (that has the song on it), and the 3/4-inch edit master. The time code numbers on the 3/4-inch edit master will match the time code numbers on the one-inch master. The window time code numbers on the 3/4-inch master will match the time code numbers on the camera original one-inch tape. Once the two tapes are in sync, then you can start laying clean video on to the one-inch master tape. If you want to do any effects, it is at this time you lay them in using an ADO (Automated Digital Optics), a DVE (Digital Video Effects), or the like.

The off-line edit should last no longer than three days and usually costs about \$35 per hour, however deals can be made so it's much cheaper.

The on-line session should last no longer than eight hours, and usually costs around \$250 per hour, but deals can be made to cut that expense too.

Editing on Film

As you can see, to shoot on film and edit on video tape requires a lot of time and preparation, many different stages of pre and post production, and can run into a lot of money.



Same lyrics, different locations allow the "set" to change with a musical phrase

To edit a rock video on film creates different problems. The main differences are as follows:

1—For editing purposes, the song should be transferred to 16mm or 35mm magstock, depending on what format you are shooting, instead of to the one-inch and 3/4-inch video tape. (Unless you are shooting Super-8 double-system-sound, in which case you will need the song transferred to Super-8 magstock.)

2—The scratch track recorded during shooting should also be transferred to magstock and rushes synched to it.

3—You should then cut the show on a six plate, allowing yourself to put the original song magstock on one track, and the picture and sync sound on the remaining sound and picture heads. Sync up



Hand held two-shot moves past singer to capture guitar solo in close-up

both tracks so that the sound is running together and edit your picture to match the original song.

Once you have a frozen cut, you can do one of two things: Have the film negative cut, with a low-con print struck from it and transfer that to one-inch video tape; or do a sloppy transfer of the selected negative to one-inch video tape. I would recommend the former, as it is cheaper and the generation loss is negligible.

There are still other ways to cut a rock video, most not as complex and efficient as these, but cheaper.

Video Adventure

I was in a situation to shoot, direct and edit a rock video with a total budget of \$2,000, and I did it. I got a call on a Thursday night to shoot a band performing the following Friday night. I rented a camera and showed up. I shot the guys like mad, running all over the stage with them—even filming them getting dressed. Then I had the film developed. I had shot with 7294, the fastest 16mm Kodak color stock, because I knew I would be filming with available lights. Luckily the band's stage show had lots of lights, and when the footage came back, much to my surprise and delight, it looked great. Even so, I shot a second night, still having no idea as to what song we were going to use for our video.

By the time we were finished, I had about two thousand feet of film of the band performing completely out of sync. We decided on a song to use. I had the record transferred to 16mm mono and 35mm stereo magstock and started lip-syncing the video. The lead singer and I looked through the footage and pulled the best shots out. Then I separated them in terms of content: bass player, drummer, singer, full shot, etc. I cut the video in two days (two very long days, I might add) on a four plate. When it was done, I had the negative cut, stuck a low-con print, and transferred it, double system using the 35mm, in a film-to-tape transfer.

We shot the piece in two days, without playback, and finished it in another three. Sweet, neat—and *Cheap!*

It all worked out, but let me tell you, it was tough to edit. If I were to do another one, I'd shoot it on film and transfer everything to video tape. It costs a little more, but in the long run saves you time and the quality is much better.

Rock videos are great. You can be as creative and weird as you like in interweaving a story with the band's performance. The fact that most videos are only three minutes long limits the time you should spend on it, but also makes them easier and cheaper to produce. That's not to say you shouldn't do your best, but it's not as big a commitment as shooting a feature or even a longer, narrative short subject. So get some film, find a band and shoot them! Just be forewarned, the entire process could drive you video-ga-ga.

CM

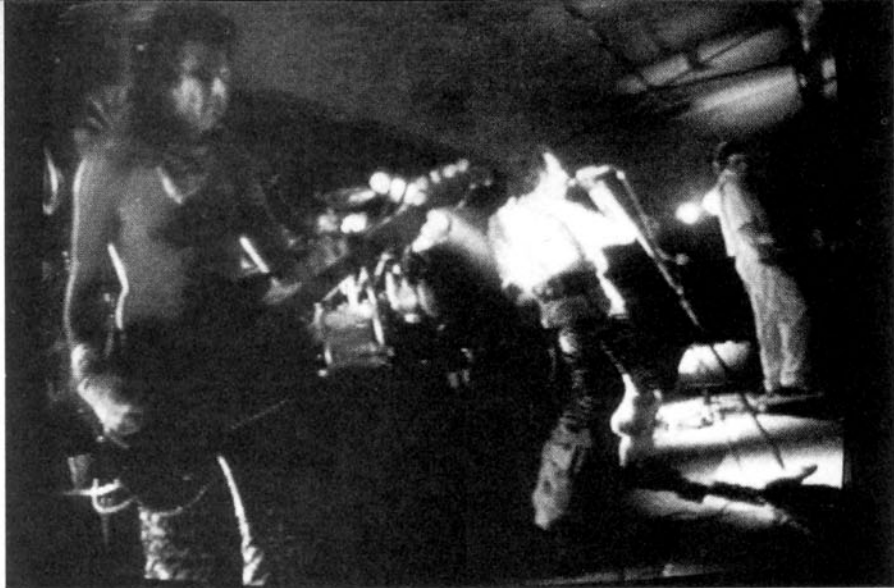

Slow-motion sequence

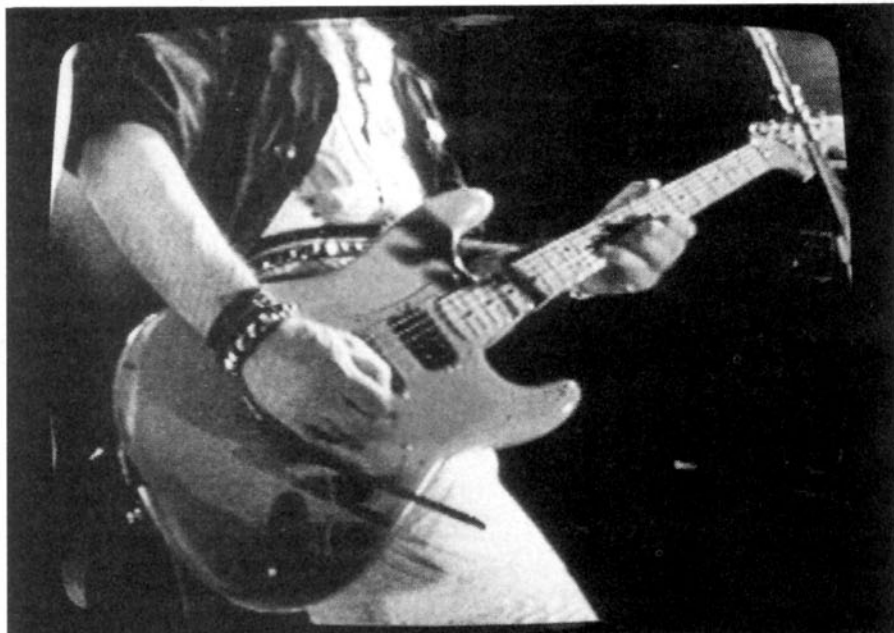

A close-up of a guitar solo is a standard shot for a performance video.

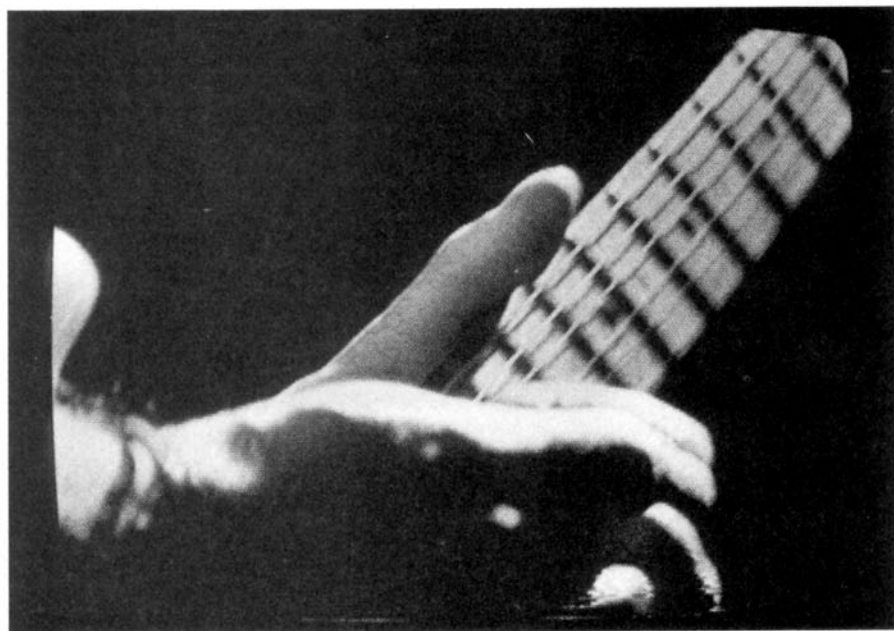

Extreme close-up covering guitar solo

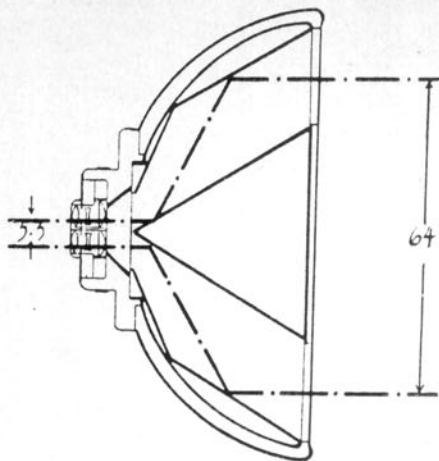

This diagram of the Bolex Twin Lens and Beam Spreader attachment shows the path of light rays through each aperture, spaced at normal interocular, and then through prisms to the film via two side-by-side lenses.

(continued from page 20)

half-silvered mirror and the other is a front surface, which is about two inches off axis. The mirror separation is not adjustable. Properly placed red and green filters, color and the left and right eye images as they are superimposed for the camera's lens. The filters and mirrors absorb a good bit of light, requiring an extra 2½ to three stops exposure.

The filters and mirrors are enclosed within the camera attachment, which is fitted to your camera with a universal bracket (supplied). An extra adapter is available for folding handgrip cameras, such as the Bauer. Projection requires no special attachments at all. You may pro-

ject the film as you would any film, and on any screen.

Even though you will be using color film in the camera (black and white film will not work), there will be no perception of color. The color layers of the film are being used to encode the left and right eye images; the 3-D image, as viewed through the red/green glasses, will appear in black and white or slightly sepia toned.

While the Spondon 3-D attachment will work with almost any camera, it is preferred that the lens diameter be no larger than 38mm and not recessed more than 12mm. Larger lenses will result in vignetting. If your camera is equipped with a zoom lens, you should have the focal length set at "normal"—25mm for 16mm cameras, 15mm for Super-8 cameras and 12.5mm for regular 8.

For complete information regarding the Spondon 3-D anaglyph attachment see the address listed at the end of this article.

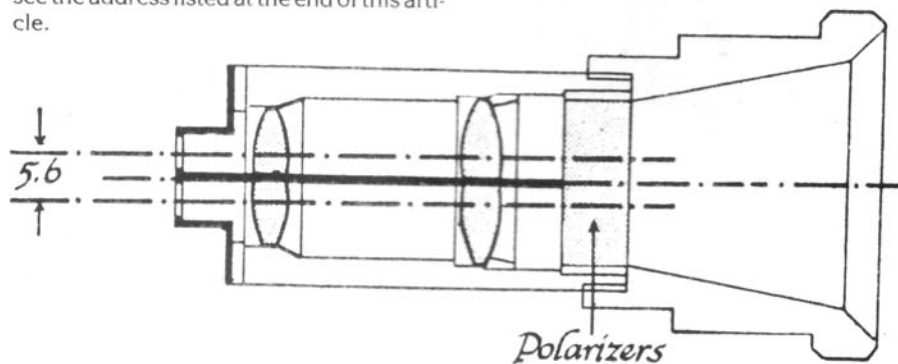

The Bolex Twin Lens Projector Objective has twin lenses and built-in polarizing filters. The optical axes are 5.6mm apart.

3-D SOURCE LIST

Further Reading

Foundations of the Stereoscopic Cinema—A Study in Depth by Lenny Lipton. A comprehensive 319-page guide to 3-D filmmaking by a well known proponent of the Super-8 format. Available from Reel 3-D Enterprises, \$21.95 plus shipping. See address below.

Fantastic 3-D by David Hutchison. A lively survey of 3-D movies and comic books, including annotated indexes and numerous 3-D illustrations. Glasses included. Available from Starlog Press, see ad on page 17. \$11.95.

How to Make Your Own 3-D Movies by Lenny Lipton. This three part article originally appeared in *Super-8 Filmmaker* nearly a decade ago. All three parts are available as back issues from Super8 Sound, 95 Harvey St., Cambridge, MA 02140. Ask for: Volume V No. 7; Volume V, No. 8; and Volume 8, No. 1. Send \$9.00 for all three issues, shipped postpaid.

Used 3-D Equipment

Mr. Poster, P.O. Box 1883, So. Hackensack, NJ 07606. An established dealer in 3-D still cameras and accessories, who may occasionally have 3-D movie attachments available. Send a long (#10) self-addressed, stamped envelope for a copy of his latest list.

Ron Speicher, P.O. Box X, Far Rockaway, NY 11691. Send a self-addressed, stamped envelope with your inquiry concerning 3-D movie equipment. Remember, all 3-D movie items are rare, but a dealer will put you on a waiting list of you have a specific request.

Shutterbug, P.O. Box F, Titusville, FL 32781. A monthly tabloid publication advertising used photographic equipment of every kind.

There are regular sections devoted to movie and 3-D equipment. A subscription costs \$12.00 for one year.

Anaglyph Movies

Spondon 3-D Attachment. A simple to use 3-D anaglyph system is supplied as a complete kit from Spondon Film Services. The unit is suitable for most Super-8 and 16mm cameras, but you should make written inquiries before placing an order. Anaglyph films may be shown on any projector and on any screen. The kit includes: 3-D camera attachment, universal fixing bracket, four pairs of viewing glasses and instructions. Cameras with a folding handgrip require an adapter bracket, available at a small extra charge. Complete kit sells for 69. For ordering information write to: Spondon Film Services, 5 Charles Avenue, Spondon, Derby, DE2 7AJ, England.

How to Make Your Own 3-D Movies by Lenny Lipton. This three part article originally appeared in *Super-8 Filmmaker* nearly a decade ago. All three parts are available as back issues from Super8 Sound, 95 Harvey St., Cambridge, MA 02140. Ask for: Volume V No. 7; Volume V, No. 8; and Volume 8, No. 1. Send \$9.00 for all three issues, shipped postpaid.

3-D Supplies

Reel 3-D Enterprises, P.O. Box 35, Duarte, CA 91010. The world's largest mail order source for new 3-D supplies. Owned and operated by knowledgeable 3-D enthusiasts. Send \$1.00 for a copy of their latest catalog. From time to time, they will have a few used 3-D still cameras and, occasionally, 3-D movie equipment for sale. Excellent catalog includes 3-D books, viewers, a variety of polaroid glasses and other hard to find 3-D accessories.

The Great Mouse Detective

More than just another animated "Mouse" adventure, this animated feature hints at the coming revolution in animation.



Basil and Dr. Dawson are on the track of Ratigan. Dawson was inspired by veteran animator Eric Larson, one of Disney's "Nine Old Men" and animator Hamilton Lusk's assistant in the 1930s. Even some of Larson's mannerisms have been immortalized in the animation.

ART: © 1986 BUENA VISTA

Based on *Basil of Baker Street*, a series of children's books by Eve Titus, the project was first proposed at Disney many years ago—as far back as during the production of *The Rescuers* (1977), and kept alive over the years with the assistance of the younger generation of animators, some of whom were fans of Conan Doyle's Sherlock Holmes stories.

Holmes, the real Sherlock Holmes, is never seen; as far as the Disney animators are concerned, Basil is Holmes and the human world is barely noticed. But Basil is not a watered-down Holmes, the characters have their own reality. This is not "Sherlock Holmes with Animals," but the complete creation of a miniature world, very much in the tradition of "The Mag-

nificent Mr. Toad" from *The Wind in the Willows*.

Produced by Burny Mattinson and directed by John Musker, Dave Michener and Ron Clements, *Mouse* represents a return to the rich character style of *Song of the South* or *Wind in the Willows*. The emphasis for the animators is not what it was in *The Black Cauldron* with its massive crowd scenes and vast sweeping action, but more focused on the individual characters.

"Character animation is at the very heart of this picture," affirms Ron Clements. "The animators are absolutely integral to developing the personalities of the characters." In some films, an animator does little more than illustrate the story with his drawings. But in this

film, the on-screen drama is created by the artists through the sheer force of the personalities they create on paper.

"Everything that happens up to the point an animator picks up a pencil—script, storyboard, etc.—is just *planning*. The story just suggests a direction, but the animator, the really top animators, determine the character's personality. From that, comes the drama. And that is the way it should be! This is an animator's medium, not a director's."

"Other studios pour all their creativity into story, layout and design. The animation is just 'move it around a little,' adds John Musker.

"Stylistically, the film is much broader than the last few films I've worked on. It's more cartoony than *Fox and Hound*,



Animator Sandy Borgmeyer checks off key poses on her timing sheet.

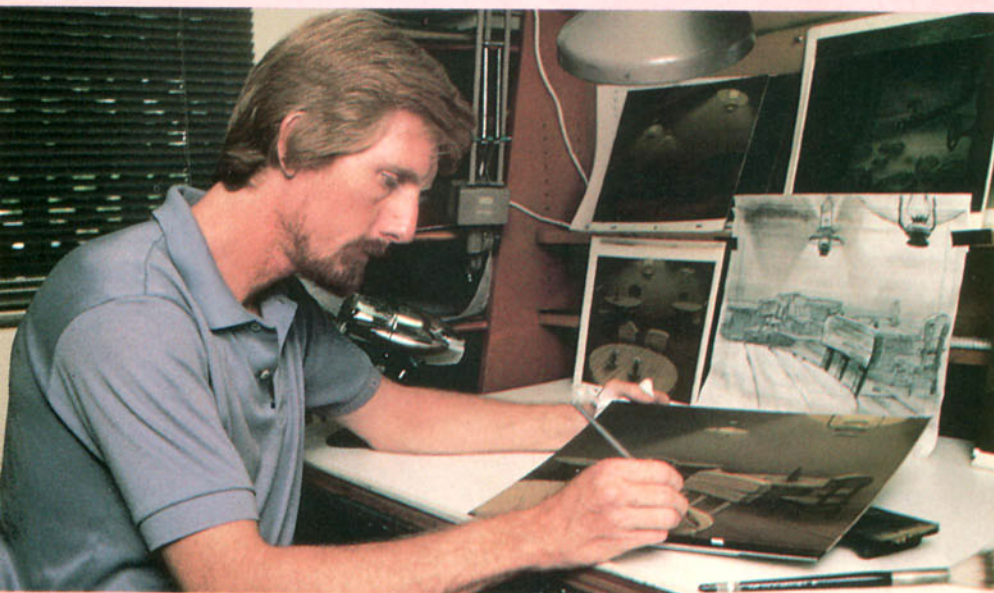

Artist Brian Sebern prepares a few of the numerous backgrounds required in an animated film.

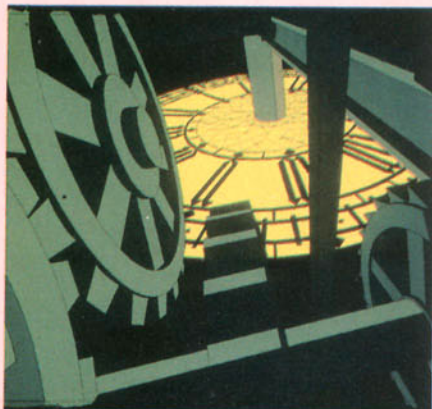

A view up through the clockworks of Big Ben. Turning gears and wheels were animated by computer, which rescued the effects animators from months of tedium.

ARTIST: 1986 BUENA VISTA

Cauldron, and even *Rescuers*. It's closer to the flavor of *Wind in the Willows* and *Song of the South* as far as the feeling of caricature. It's simpler. Our attempt was to create characters who were easier to draw and construct, and who could afford more caricature in their expression."

The Disney animation team has been working under the close scrutiny and direction of the Company's new management team: Jeff Katzenburg and Michael Eisner, formerly of Paramount, and Frank Wells, who came over from Warner. By the time the new team took over, all the character's voices had been recorded, music and song tracks had been worked out and a good portion of animation completed. They suggested a number of changes, which they hoped would make

the film more marketable. In spite of the fact that the picture was set in 19th century Victorian England, they wanted a modern score. In particular, it was suggested that Michael Jackson and Madonna should do a few songs.

Moreover, Disney management voiced concern over the less than boffo business that Paramount's *Young Sherlock Holmes* garnered. Obviously, the public was not interested in Sherlock Holmes, they reasoned. Disney marketing decided to distance themselves from the Paramount film by changing the title from *Basil of Baker Street* to *The Great Mouse Detective*.

Only a few months before the film's completion, marketing expressed dissatisfaction with the character's English accents. Could the film be re-dubbed with a more "American" sound? Yes, but only at great expense and many months of work. Other studios animate characters with flapping mouths in rough sync to the dialog, but Disney animators work very precisely to the spoken word. In the end, management decided it was too expensive to change the voices.



Vincent Price emotes for Ratigan.

Animated Backgrounds

One of the most startling sequences in *The Black Cauldron* involved the use of animated background. It happened early in the film when the Horned King's flying minions and snatch Hen-Wen in their claws. Phil Nibbelink was responsible for this visually dramatic sequence in which the camera appears to be flying a few feet above the ground. Hills and trees come flying towards the audience in this unusual sequence.

Animated backgrounds are not new, but they are very rare. Back in the early



Animator Glen Keane based villain Ratigan's character design (inset) on Ron Miller, the former head of the studio. Keane was also responsible for the designs of Ratigan, Fidget the bat, and Olivia, as well as animating Ratigan's key scenes.

1930s, Max and Dave Fleischer built three-dimensional scale models to use as backgrounds for animation. A special horizontal animation camera was built with a special easel that suspended the cels between the camera and the background which revolved on a turntable.

Disney's great contribution to creating realistic backgrounds was in the form of the multi-plane camera which allowed the camera to dolly through landscape. *The Old Mill* (1937) premiered this technique.

Great Mouse Detective has been produced under very severe budgetary restrictions. After *Black Cauldron* was completed, animators and management alike were embarrassed by the enormous cost over runs incurred by that production. Steps were taken to make sure that didn't happen on the next film. The first cut back was in running time. The animators had to eliminate 20 minutes of story to bring the picture in at about 72 minutes. Other restrictions involved production values—only a single color of Xerox toner was allowed (black) and the characters were limited to about nine colors. In the past, a character may have required more than two dozen colors, depending on the lighting and mood of a scene.

The animators were also under the gun to work on a very short schedule. "We pretty much had to eliminate the rough in-between phase," explains director John



Layout artist Dan Hansen sets the stage.



Musker. "An animator will shoot pose tests, that will not be in-betweened until after clean-up. In other words, they clean-up the extremes, the rough extremes, and then it's in-betweened. So you never see an in-between test until after it's cleaned up and a fair amount of money has been spent on it. It really puts a lot of burden on the director and the animator to be guessing right.

"It's been pretty tough for the novice animator, who isn't quite as familiar with timing or exactly what the effect on the screen is going to be, to work in that system. There is much less margin to go back and adjust things. We have changed some things, but we are having to live with some things that we might, in another system, have gone back and said, 'Shoot! We made a mistake in this; let's go back.' And then, in some cases, we've had to say, 'Close enough.' So we've thrown some animation out for one reason or another, but a lot less, I'd say, than *Cauldron*."

Entire backgrounds were animated by hand in *Three Caballeros* (1945) for the Bahia sequence in which Brazilian entertainer Aurora Miranda walks through a town of dancing buildings.

But imagine the complexities involved if a camera were to follow an animated character as he walked around a room or through a landscape. Figuring out intricate changes in perspective is too tedious a job for any artist; it's a job for a

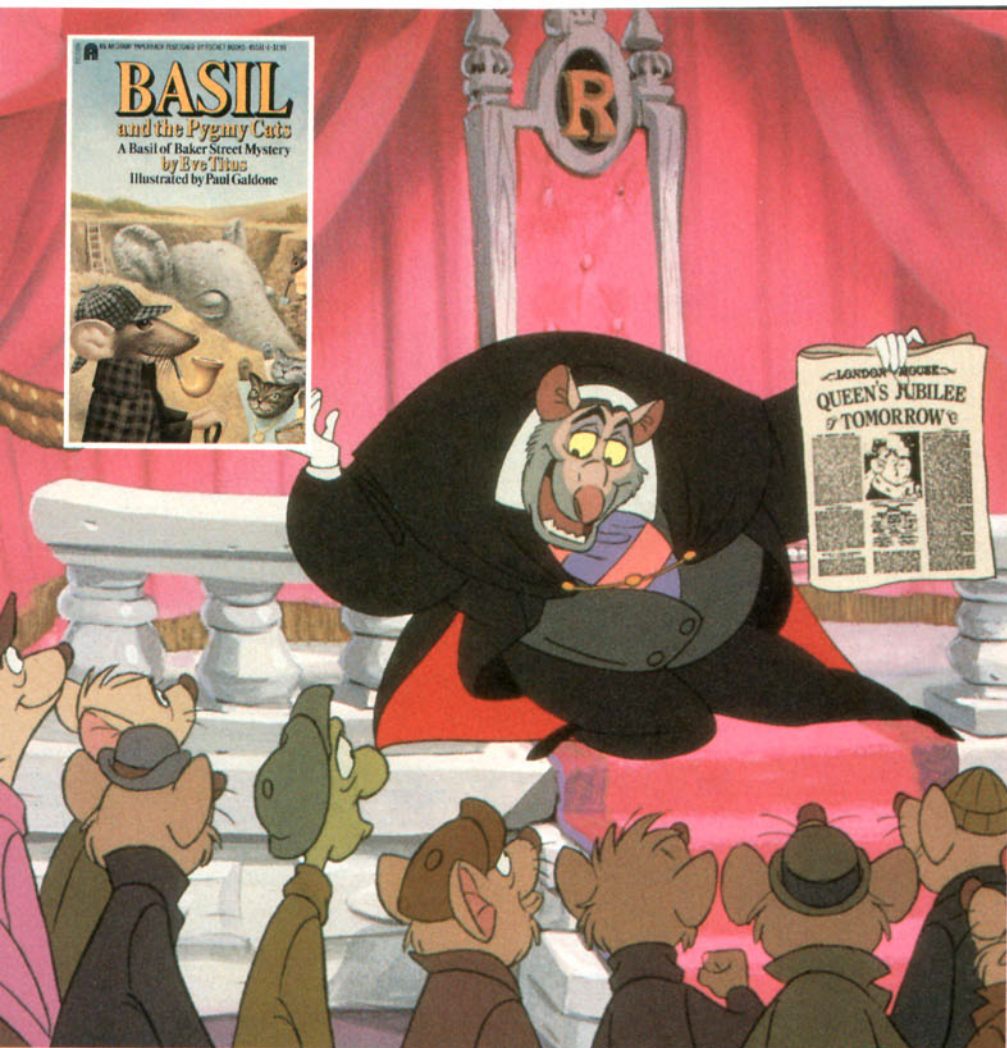
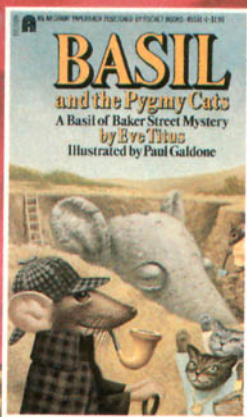

ART: © 1986 BUENA VISTA

Ratigan announces his latest scheme. Inset: The film is based on the famous series *Basil of Baker Street* by Eve Titus.



Kathy Zielinski flips through her animation of Fidget the peg-legged bat.

computer. Not long ago, a test was made at Disney using a sequence from Sendak's *The Wild Things* (see STARLOG #77) in preparation for the proposed filming of Thomas Disch's story *The Brave Little Toaster*. Rapid camera moves and startling subjective points of view were demonstrated in the short test. But while the animators were enthusiastic, Disney

management put Disch's story into turnaround.

The climax of *Great Mouse Detective* takes place in the clock tower of Big Ben amidst the complex turning and thrashing clockworks. During this dramatic two-minute sequence, characters (animated in the traditional, painstaking manner by Disney artists) move through a room con-

sisting of 54 moving gears, winches, ratchets, beams and pulleys, which have been literally drawn by computer.

The credit for this innovative sequence belongs to animator Phil Nibbelink and Ted Gielow, his associate from Walt Disney Imagineering and a specialist in computer programming for graphic artists.

"This sequence represents a hybrid of what the computer does best and what animators do best," says Nibbelink. "A computer is adept at creating precise, geometric man-made or inanimate objects. If an animator tries to draw a gear or a car or house, it's imperfect. What we do best is fluid organic character animation. By combining the two, we get the best of both worlds and, hopefully, create a more believable and exciting world for the characters to interact in."

Nibbelink cautions that computers are not yet ready to handle the kind of personality-oriented animation, which is the hallmark of Disney animation. But, as a tool, computers can be used to solve the myriad complex problems of changing perspective in a moving camera shot.

Several months were spent designing the interior of Big Ben in accord with storyboarded action. Their designs were digitized—built point by point in the electronic brain of the computer. Once the computer had an idea of what the room looked like, Nibbelink used a simple joystick to move around the room and establish a point of view from literally anywhere.

"In being able to create the entire room, we were able to do the kind of cinematography that's not normally possible," explains Nibbelink. "In normal animation, we are limited to simply trucking in or panning left and right on a flat piece of artwork. With the computer, we can rotate around the whole room and do any kind of camera move that best suits the drama of the situation. For the first time it was possible to approximate helicopter or Steadicam shots in which the camera is floating free in the room and flies over gears, skimming over the teeth as the characters are running for their lives."

After the sequence is completely laid out in the computer, the computer prints out the background on a printout sheet of animation-size paper—one printout for each frame of film. These drawings are then Xeroxed onto cels and painted in the standard fashion. Character animators must match the changing perspective of the moving camera as they work in a sequence, effects animators have been saved the agony drawing dozens of slowly rotating gears and wheels.

Many animators at Disney are very excited by the possibilities that have been opened up with greater use of a moving subjective camera effect. Computer generated scenes will be the biggest change in film—live action and animated—over the next five to ten years.

FRONT VIEW OF REFLECTOR

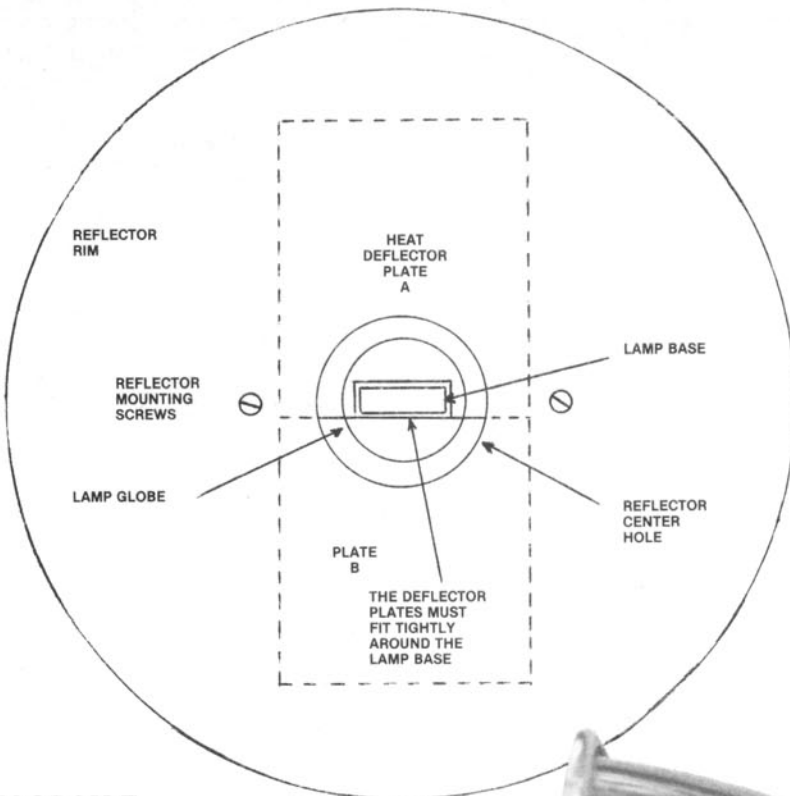

DIAGRAM F

well. The 600-watt, 3400° Kelvin tungsten-halogen lamp is far superior to conventional photoflood bulbs in that both light output and color temperature remain virtually constant throughout its rated 75-hour life.

For the serious filmmaker or videographer on a budget, several of these units together can form the basis of a functional studio lighting set-up each being built for less than \$40—including the lamp.

Materials

You will need the following readily available materials: One aluminum mixing bowl, about 7½ inches in diameter, and 3 inches deep; one Radio Shack #270-235 chassis box; ¾ x 1/8 x 24-inch stell flat stock; one light stand adapter with ¼-20 threaded stud; Crimp-on terminal lugs, Radio Shack #64-406; one type DYH T/H lamp; #16 gauge two-conductor wire; 8 in-line on/off switch; one standard two-prong electrical plug; assorted vinyl grommets, Radio Shack #64-3025; assorted wood screws, washers, nuts and bolts, two-scraps of sheet aluminum, and a small block of hard wood; general collection of home workshop tools, preferably including a ½-inch diameter sheet metal hole punch, an adjustable hole cutter, and a lug crimper.

CM

(continued from page 9)

vent heat produced by the operating lamp from entering the lamphouse and overheating the base block and wiring. To install the plates, simply loosen the reflector mounting crews (*Not* the lamp mounting crews), slide the plates between the lamphouse box and the back of the reflector, then retighten the reflector screws firmly. After you have attached the plug and in-line on/off switch to the power cable, your fill light is ready for use.

Safety Note: This project is completely safe if built and operated as described. However, if this is your first electrical project, have the finished work checked by an experienced do-it-yourself before its initial use. The DYH lamp produces a considerable amount of heat during operation, so always keep the reflector at least three feet away from any flammable surface. Remember, the tungsten-halogen lamp is especially vulnerable to breakage when hot, so avoid jarring the unit when it is in use, or until it has cooled completely. Clean any fingerprint smudges from the globe of the lamp with a soft cloth to prevent it from shattering due to uneven expansion. *Never* operate your fill light without the heat deflector plates in place.

Advantages

This powerful unit has many uses in the film and video studio, yet it is light-weight enough for convenient location use as

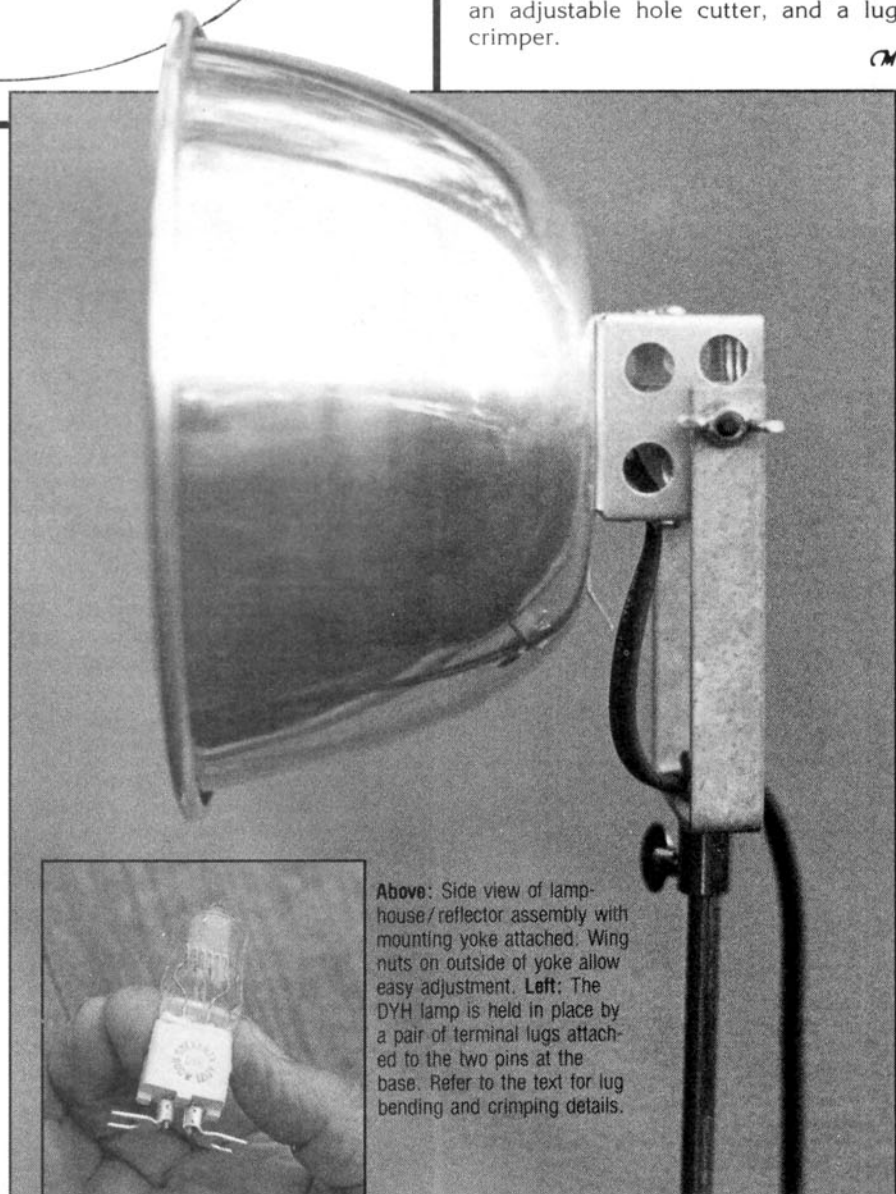

Above: Side view of lamp-house / reflector assembly with mounting yoke attached. Wing nuts on outside of yoke allow easy adjustment. **Left:** The DYH lamp is held in place by a pair of terminal lugs attached to the two pins at the base. Refer to the text for lug bending and crimping details.

CAREERS

By DAVID BACON

Stephen Frears: 16mm Goes Legit



Omar (Gordon Warnecke), an ambitious Pakistani in his late teens, convinces Johnny (Daniel Day Lewis), an old schoolfriend who hangs out with a group of racist white youths, to help him manage a seedy and unprofitable South London laundrette. With money raised by the sale of drugs stolen from a Pakistani pusher, Omar and Johnny transform the laundrette into a "Ritz among laundrettes," a gaudy, neon-lit palace of a gathering place called "Powders," complete with an aquarium, video games, potted plants and a deejay console pumping classical music among the washers and dryers.



In the United States, filmmakers have three basic formats in which to work: Super-8 for home movies, 16mm for TV news documentaries and 35mm for theatrical features. In Europe and many other parts of the world, filmmaking categories are not so tightly drawn. Super-8 and 16mm formats are more popular than in the United States; 16mm is treated much more seriously and can be the format of choice for theatrical motion picture production.

Recently, a British filmmaker, Stephen Frears, chose to shoot a feature film in 16mm. Frears admits that 35mm would have been his automatic choice for a feature, but that budget and production economies dictated the 16mm choice. It was not his first outing with the smaller for-

mat; Frears has a very solid reputation in England for making TV movies, which are generally shot in 16mm. And this film, *My Beautiful Laundrette*, was specifically commissioned for television.

mat; Frears has a very solid reputation in England for making TV movies, which are generally shot in 16mm. And this film, *My Beautiful Laundrette*, was specifically commissioned for television.

Frears was pleased and surprised when *My Beautiful Laundrette* garnered lavish praise from critics and began winning notoriety in festivals. The film, which had started out as a low-budget, 16mm TV movie, was picked up by distributors for big time theatrical distribution. Since few movie houses can project 16mm films, it was blown up to standard 35mm, and has been playing to worldwide acclaim.

Part of the reason for *Laundrette's* big time success as a 35mm blow-up is the high quality image. It doesn't look like a 16mm movie. The colors are rich and saturated, and the image is fine grained and highly detailed. Careful attention to the technical side of filmmaking—lighting, camera technique, etc.—has allowed Frears to compete with the gloss of 35mm.

Though Frears insists he shot *Laundrette* only for television, the film has a big screen look. The endless sequences of talking heads which populate TV movies are not in evidence here. *Laundrette* is a stylish, high energy mix of unusually rich characterization and rapid pace action.

The script is by one of England's most respected and controversial young playwrights, 29-year-old Hanif Kureishi, who was born in South London to a Pakistani father and an English mother. The material for *Laundrette* was developed by the request of Britain's Channel Four Television. Kureishi submitted the finished script to Frears, who immediately agreed to direct the film.

Frears assembled an interesting mix of highly talented and very experienced actors with some equally talented newcomers to films. His actors' credits ranged from lead roles in Attenborough's *Ghandi* and Lean's *A Passage to India* to Spielberg's *Indiana Jones and the Temple of Doom*. All of them were seduced by the power of *Laundrette's* script and Frears' professional dedication to the project. The characters are remarkable. Frears and Kureishi have the power to create characters that are, on the one hand, perfectly ordinary people, but within the film's 93 short minutes become absolutely fascinating. The characterization is so skillful that any one of them could have their own film. Frears found himself in the enviable position of obtaining the services of leading actors even for walk-on bits. The parts are that good.

In the past Frears has worked with the Academy Award winning British cinematographer Chris Menges (*Killing Fields*,

Local Hero), but the film's low-budget obliged Frears to work with fresh faces in key positions, many of whom had never worked in their respective capacities on a feature film before. Frears appreciated the younger crew's energy. Working in 16mm on a six-week schedule, Frears moved quickly and efficiently from location to location in London.

"I don't shoot a lot of coverage," Frears admits. "The more inexperienced you are, the more film you shoot, because you haven't learned how to do shots that tell what you want to tell and express the moods, emotions and ideas you want. For some reason, we were very confident about making *Laundrette*. I don't mean confident that it was going to be a success, or anything like that, but the people making this film *knew* the material. The actors were very clear about it, the writer was clear about it. And when you have material that is so original, you don't need to shoot a lot of coverage; you just need to be able to shoot close-ups for emphasis."

For Frears, filmmaking is a very close knit collaboration of artists. While he knows very specifically what he is looking for in any given shot, he relishes moments of creative spontaneity that can come from anywhere—cast or crew. His style is fast, intense and highly dramatic. He peers at life with his camera and generates excitement on the screen. "All films are sort of like acts of piracy, aren't they?" he muses. "It's so unnatural to make a film; you see a little chink of light and go for it."

Frears and his cameraman shot on various locations in London. But the laundrette was a set built on location. Its broad expanse of storefront glass would have been a nightmare for cameraman. Standard interior lighting would have let the background street action bleach out to a formless white in the London sunshine. But Frears loves to balance exterior light with interior scenes. Action is played out in the laundrette with the big glass windows revealing the background of the London streets. In fact, most of Frears locations have open windows with the city skyline as backdrop. "That's where life comes from, isn't it?" Frears believes. "It comes in through the doors and the windows. If you burn them out, it's all gone, wasted. A waste of what God's given you."

When filming was completed and Frears had assembled a rough cut, he found he had a very long film that wasn't quite working the way he had originally envisioned it.

"I put it all together and looked at it with a group of friends. It was quite apparent that I had the potential for a very serious film—the content was really good. But the tone wasn't quite right. There were a lot of somber, dark speeches.

"A lot of time when you are editing, you are trying to get your film to be about something. When the rhythm works, then the content comes to the surface. Well, this film had content spilling out of it.



Daniel Day-Lewis, whose credits include *Ghandi*, *The Bounty* and *A Room With A View*, stars as Johnny, a tough punk who decides to make something of himself by helping a young Pakistani on the road to capitalist success.

When the content is that strong you can be much less intense about cramming it down peoples' throats. There were lots of long speeches about contemporary life in England. We took them all out, because they were unnecessary. It was all quite apparent from the drama and the characters, people didn't need to be told about it. We

Johnny (Daniel Day-Lewis) stands by uncomfortably as Omar's father (Roshan Seth) arrives twelve hours too late for the grand opening of his son's neon-lit laundrette.

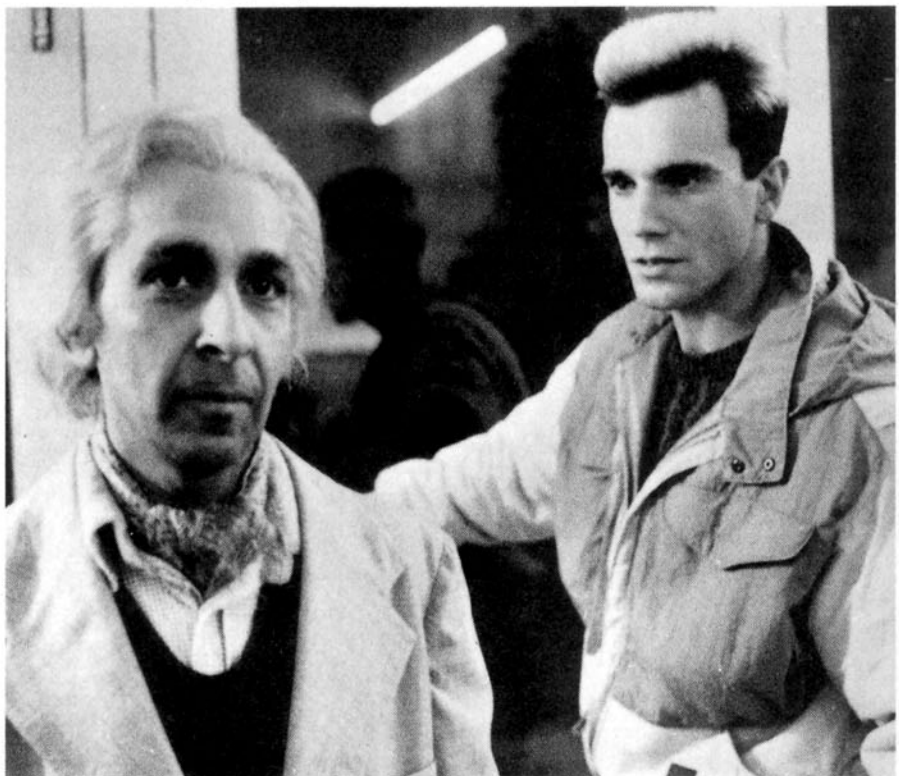

PHOTOS: © 1986 Orion Pictures Corporation

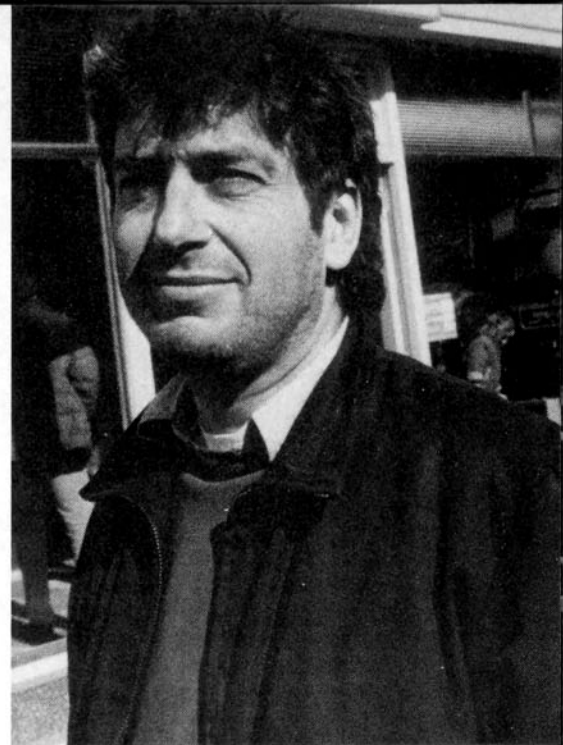

Director Stephen Frears, veteran of more than two dozen television films and two features, combines the best of both worlds by making a low-budget 16mm film intended for television into a big-screen theatrical hit.

were in the enviable position of being able to treat serious issues very lightly and still have the message come across."

Frears is also in the enviable position of having produced his award winning film for a mere \$900,000. With average Hollywood features coming in at \$12,000,000 and up, West Coast producers would do well to re-examine the economies of the 16mm format. The result is a money-making, high quality 35mm feature film, produced in money saving 16mm. CM

Coming to Terms with Blue Screen Photography

By PAUL MANDELL

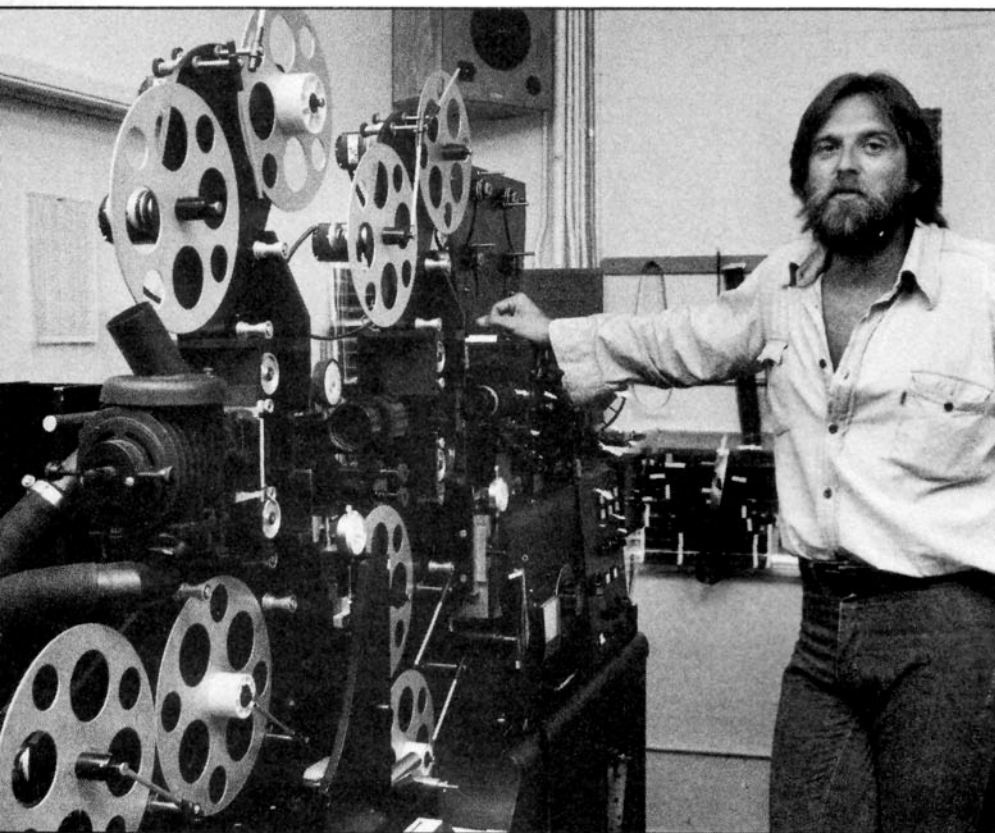

Got the travelling matte blues? Get rid of them, once and for all.

Question: OK, it's confession time. I've seen the term "blue screen travelling matte" in every book and article I've ever read on special effects. But frankly, I just don't understand it.

Answer: Don't fret. You're not alone. Many special effects fans have the same problem. But don't let it rattle you. It's just one way of combining a previously filmed background scene with a studio-filmed foreground scene, be it a spaceship or an actor in motion. Understanding the technique is not that horrendous—it just requires a visualization of the various steps involved during the printing process.

Q: I know that you're double-exposing one image on top of another somehow.

A: Right. The big difference is that in a simple double exposure, one image can be seen *through* another. You've seen double exposures in ghost movies, where people are intentionally transparent. In situations like that, the actor playing the ghost was filmed against a black velvet

drape, on a blackened set. The background scene with "normal" people in it was filmed separately. Both were superimposed in an optical printer.

Of course, there's a way to avoid that transparency. You might want to make your studio actor appear as though he were standing in front of the Grand Canyon. If you could block out the *exact shape* of the actor on the Canyon film, the double exposure would no longer be transparent because the background has been masked in that area. When correctly done, it can look as though the person was actually on location.

Q: So you're masking the background with a black shape of the actor, then exposing him into that black shape.

A: Right again. Obviously, to make this system work, you need three pieces of film. One is the background scene. The second is a film of the foreground actor illuminated against a black background. The third is what we call the *matte* film—

an opaque silhouette of the actor on clear, transparent celluloid. Because this matte "moves" frame by frame, just as the actor does, it's called a "travelling matte."

If we literally sandwich the matte and the background scene together, we'd see the background through the clear area of the matte roll. The black silhouette, however, keeps the background from showing through. As you've observed, it's masking the shape of the actor, holding it back from exposure.

Q: OK, we've sandwiched the matte with the background. What's next?

A: That sandwich is duplicated onto a *new* negative (a "dupe" negative) one frame at a time in an optical printer. Result? A single strip of film of the actor's silhouette on the background scene.

See what we've done? The background has been exposed onto a new negative—*except* where the moving silhouette was. It shielded it from exposure, in the exact shape of the actor. So what we literally have is an area of *raw negative* moving against the background scenery.

Now, it's simply a matter of exposing the actor (filmed against a black drape) into this raw space. If he fills it perfectly, we have an excellent composite. If he doesn't, a "matte line" will appear around the actor. And we've all seen those!

Q: I'm with you so far. But how do you get a moving silhouette of the actor in the first place?

A: Well, in the old black and white days, the film of the actor was duplicated over and over again onto high contrast negative stock. If his clothing was bright enough to separate from the black drape behind him, all the highlights and gray tones would eventually "drop out." A *print* of this would show a clear shape of the actor moving against the drape. But the negative, of course, would show the opposite—a silhouette of the actor moving against clear emulsion. Hence, a "travelling matte." The old Invisible Man films used this technique.

Q: I'm still a little hazy on how the highlights of the actor "drop out," as you put it.

A: Well, imagine Xeroxing white and gray lettering pasted up on a black card. The first copy still retains some of the gray. But if you kept re-Xeroxing the copy, the gray tones would gradually wash out. By the time you reach your fifth "generation," you have white lettering against a very dense black background. However, if you compare the original paste up with the final generation, the geometry of the lettering changes. The lettering "bleeds." It no longer conforms precisely to the shape of the original lettering. And, if this were a matte in trick photography, you would

John Dykstra of Apogee in Van Nuys, CA displays one of his company's optical printers. The printer is used to create the various elements used in the blue screen matting process, and, finally, combine them into a finished composite.

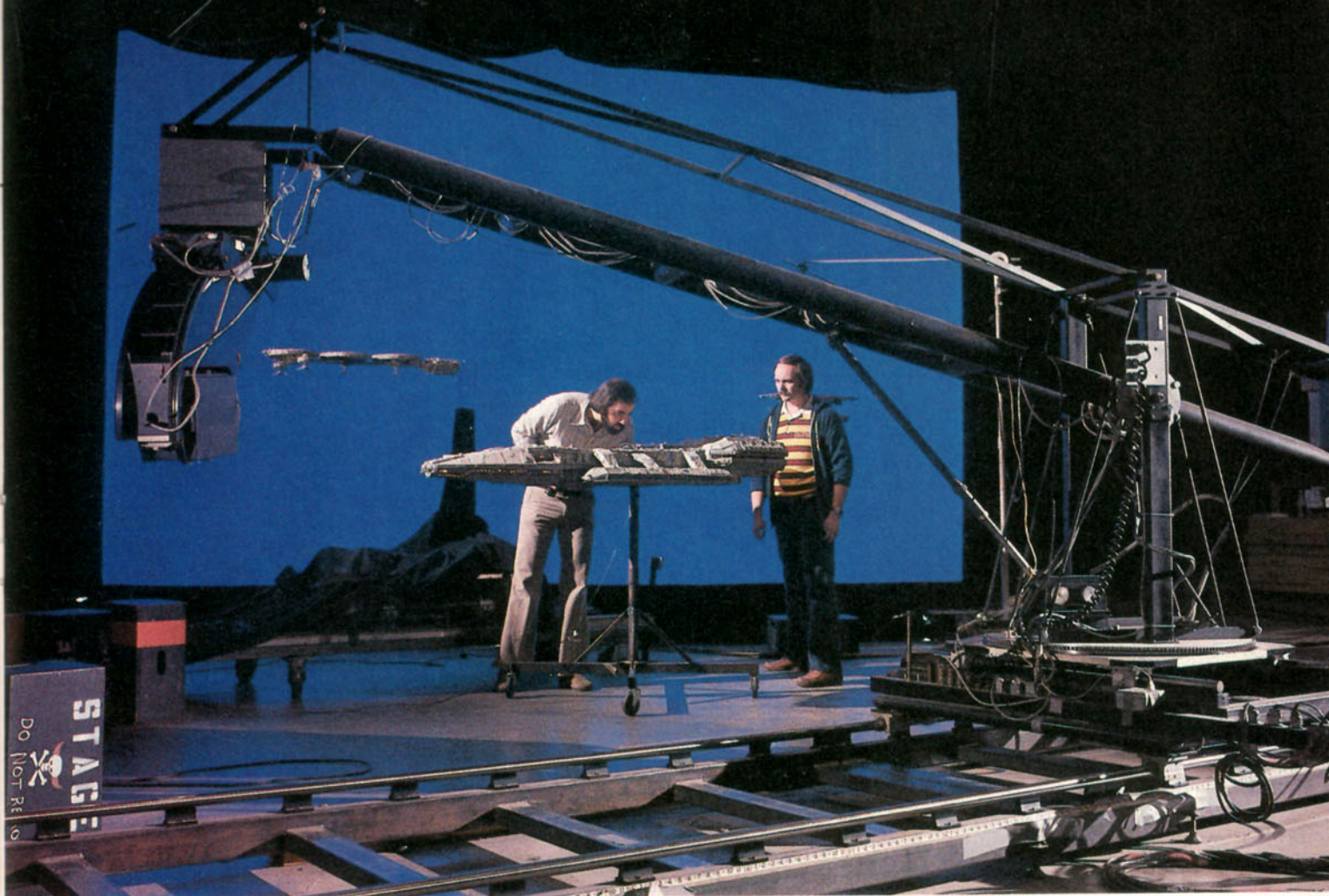

David Robin and Don Dow inspect the model of the *Battlestar Galactica* which was used for the TV series. The original Dykstraflex camera is visible in the foreground and the backlit blue screen is visible in the rear.

inevitably wind up with a matte line. That was a major problem in the old days, of duping the foreground actor repeatedly onto high-contrast stock to get a dense enough matte. With the coming of better film stocks, the technique improved.

Q: Ok, I understand the travelling matte process. But what about "blue screen" travelling mattes? How does *that* work? We're back to my original question.

A: Right. I just wanted to prepare you for it.

Q: Fire away.

A: Well, in color, the principle is the same. You have to mask the background scene with a moving matte of the actor, and expose him into the masked area on an optical printer, frame by frame. You *could* film the actor against black. But how, then, would you get a clean silhouette? Since we're now dealing with color film and an actor wearing multicolored clothing, a different method is required.

The blue screen system solves this problem rather ingeniously by having the actor filmed against a bright blue screen. Using a series of optical printing steps, the color blue is literally "filtered out" and ultimately replaced by the desired background scene.

Q: How is this done?

A: Well, the system is based on how *black* & *white* film responds to a color scene

when a corresponding color filter is placed in the optical printer. In a nutshell, the blue areas of the scene look transparent on black & white film when filtered through blue light. Conversely, the blue areas look dark on black & white film when filtered through red light. Using this principle, a travelling matte of the actor in the blue screen shot can be made.

Q: I'm getting lost.

A: Hang on. Let's take it step by step.

First, a black & white print of the original blue screen shot is made on an optical printer. During this step, a blue filter is placed in the path of the printer's projector beam. The result is a black & white version of the shot. The actor is reproduced normally. But the blue area (the screen) is reproduced as clear emulsion.

Q: Why?

A: Because blue looks clear when seen through a blue filter, remember? And "clear" on black & white film translates as transparent emulsion. We call this black & white print a "blue record" or a "blue separation." The terminology is not important.

Q: OK, I'm following you.

A: The next step is to *sandwich* this filtered black & white print with the *color negative* of the blue screen shot. If you looked at this sandwich, you'd see that the

black & white image of the actor "fills in" the negative color image of the actor. They interface. It as though they cancel each other out and create an opaque image of the actor.

Q: Go on.

A: The sandwich is printed onto *another* black & white film using *red*-filtered light. The red light "neutralizes" the yellow-orange area on the blue screen negative (the color of the blue screen in *negative* form), leaving it clear on this new B & W film. At the same time, red light increases the *density* of the "filled in" image of the actor.

The resulting black & white film (in *negative* form) shows a clear shape of the actor against a black field, and print of *that* shows the actor's dense silhouette surrounded by clear emulsion. That, at last, is our travelling matte.

Q: Whew!

A: Yes, I know. But see what we've done! We've "pulled a matte" from the original blue screen negative. We've created, via filtered light, a perfect silhouette of the actor without resorting to repeated high-contrast contact printing, as was done in the old black & white days.

Q: OK, we've got our travelling matte. Then what?

(continued on page 61)

STEP 1



Foreground element: A full size or miniature is photographed against a bluescreen of a very particular hue and brightness. The foreground element is lit in such a way as to match the lighting of the background plate into which the foreground element will be inserted.

STEP 2

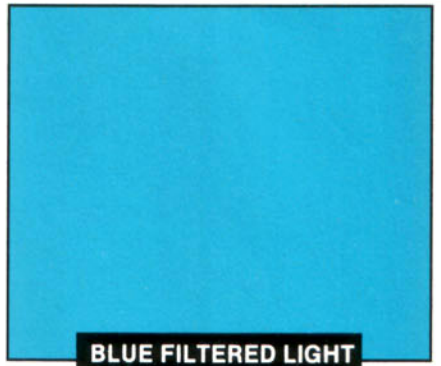
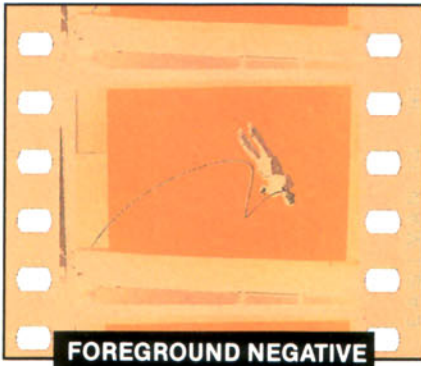

STEP 3



STEP 4

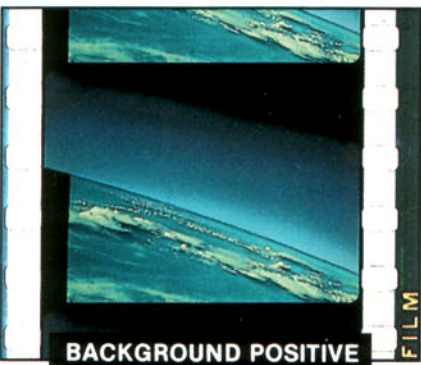

STEP 5

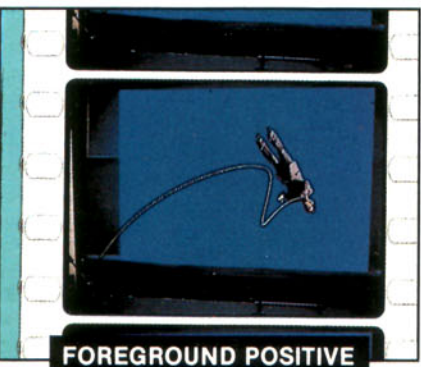

Elements from MAX Telecommunications commercial courtesy Bran Ferren. Additional thanks to John Alagna, Sandy Duke, and Mitch Wilson of The Optical House, New York City.

Background element: This is the scene into which the foreground element is inserted. The background element is called a plate and is usually shot with a pin-registered camera to insure absolute steadiness, otherwise the background and foreground will not be locked together and the illusion will be destroyed.



BACKGROUND

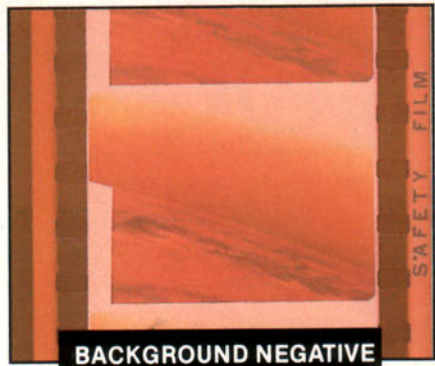

BACKGROUND NEGATIVE

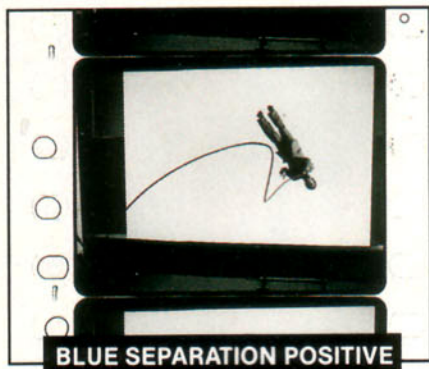

BLUE SEPARATION POSITIVE

A **blue separation positive** is prepared by printing the original color negative of the foreground element onto black-and-white film with blue-filtered light. Our spaceman foreground element is recorded normally in shades of grey, but the background bluescreen is clear film. Green and red separation positives may also be prepared at this point for making additional mattes that may become necessary in tricky or unusual situations.

The original color negative of our foreground element is sandwiched with the blue positive separation. In doing this, the positive and negative images of the spaceman cancel each other out. The sandwich is printed onto a new black and white film using red-filtered light resulting in a black and white print in which the insert area is transparent and the background is opaque. This **background mask** is printed onto another piece of film to create the **insert mask**. These masks are called **travelling mattes**.



BACKGROUND MASK

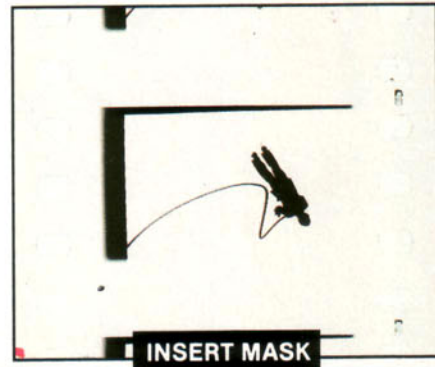

INSERT MASK

A color print (or interpositive) of the background plate is sandwiched with the insert mask and printed onto a new color negative. The mask protects the area into which the spaceman can be printed. This new negative is wound back to the beginning of the shot for the next step.

A color print (or interpositive) of the foreground element is sandwiched with the background mask and printed onto the same color negative used in the previous step. The mask protects the area into which we have already printed the background. This final **dupe negative** is developed and printed revealing our **composite**. Spaceman and background are as one.



FINAL DUPE NEGATIVE

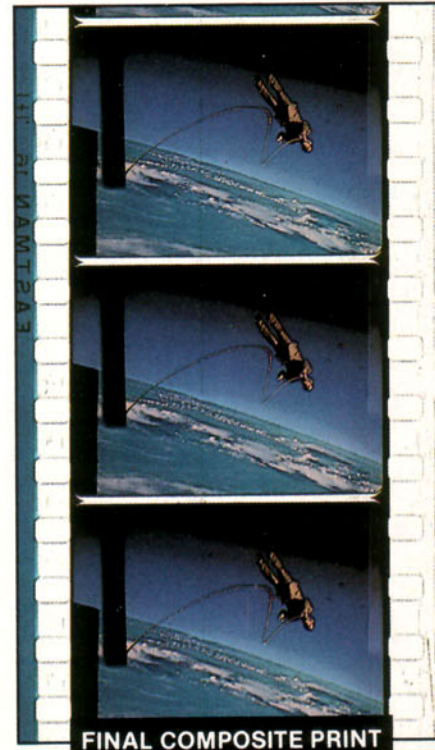

FINAL COMPOSITE PRINT

On LOCATION

By JOHN CLAYTON

The Making of “Welcome Back Mr. Fox”



In the last shot in the film, Fox lets out a harrowing scream when he realizes that he is condemned to live the rest of his life as a head in a hospital cubicle.

The winning 16mm film in the 1985 CINEMAGIC Short Film Search, Walter Pitt's *Welcome Back Mr. Fox*, is so well directed and produced that it could easily be an episode on *Tales from the Darkside* or even *Amazing Stories*—and it would stand out as one of the better episodes on either of these shows. Pitt, who made the film as a graduate thesis project at New York University film school, intentionally kept the running time to 21 minutes—the length of a *Tales from the Darkside* episode.

Welcome Back Mr. Fox is the story of a famous movie producer who has himself

cryogenically frozen after dying from lung cancer. Several decades later, he is brought back to life and finds himself lying in a hospital bed, unable to move. An overbearing, egotistical man, Fox threatens the orderlies, flirts with the nurses and makes fun of a poor girl who tries to befriend him. The girl has also been brought back to life, decades after a successful suicide attempt. Still wearing bandages on her wrists, the girl desperately seeks Fox's friendship because she feels he is the only person in the world who can understand what it feels like to come back from the dead to an alien world, decades

after every person she knew has died. In a merciless tirade of insults that reveals his true character, Fox calls her a pathetic loser and taunts, "What's the matter, Debbie, cut yourself shaving?"

Towards the end of the film, Fox makes the horrible discovery that he has no body—his body was too ravaged by cancer to be saved—he is only a head attached to a life-support machine!

"The idea for *Welcome Back Mr. Fox* came from a newspaper article I read when I was in San Francisco about a group of cryogenic facilities," Walter Pitt begins. "There was one place where it was cheaper to get your head frozen than to get your whole body frozen after death.

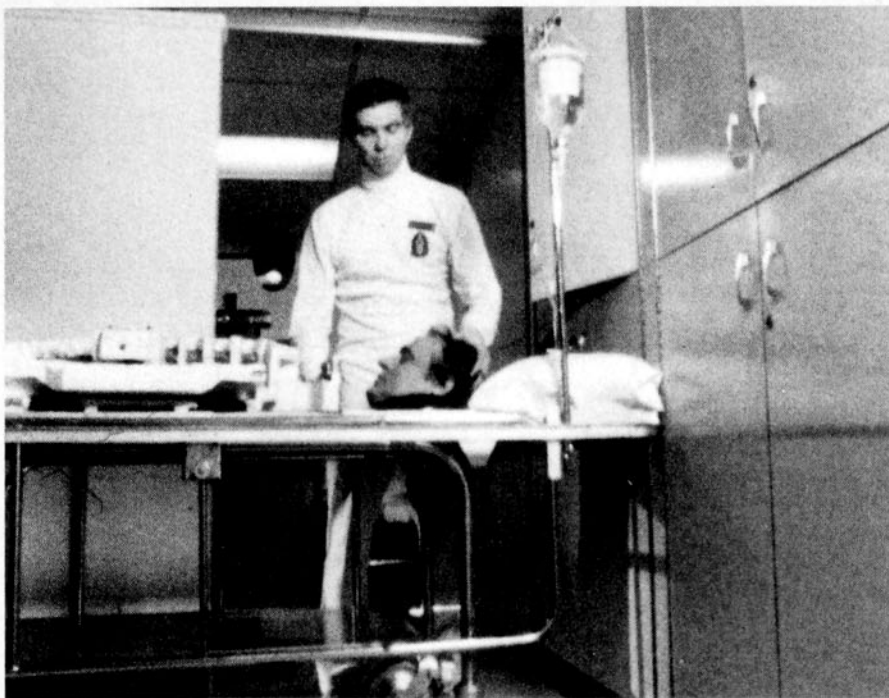

The scene showing the orderly disconnecting Mr. Fox's life-support system and rolling his head around on the gurney was accomplished through use of an in-camera matte. The gurney hides the matte line.

The places were going bankrupt and shutting down—they were discarding the bodies of people who had paid big money to be frozen until some time in the distant future when medical science could find cures for the diseases that had killed them—and could figure out how to bring them back to life. Along with the bodies, they were also burying heads.

"I thought that the idea of freezing someone's head and then bringing it back to life in the future seemed like a great idea for a movie. I had some specific goals in mind when I decided to make *Mr. Fox*," Pitt elucidates. "I wanted to format the film to fit onto television. The film is 21 minutes long—that's the standard length of a *Tales from the Darkside* episode. I had seen several *Tales from the Darkside* shows and thought I could do something better. I also wanted to work with an actor who couldn't move anything, so all you would have to work with was his head. My leading actor, Ed Phillips, is very talented. It's very difficult to perform with just facial expressions—without any body movements—but Ed handled the assignment beautifully."

Pitt used an interesting mixed bag of special effects tricks to convey the idea that Mr. Fox was nothing but a living head. "Working with special effects was new to me. My cinematographer, Bill Tunncliffe, was responsible for the visual effects. Bill was more of a collaborator than just a cinematographer, he's a very talented director in his own right and he thought up some of the more interesting shots in the film. There's a shot of Mr. Fox on a hospital gurney that establishes that Mr. Fox is just a head. It's a medium shot and all you see is the orderly, played by Gene Borio, disconnecting the head from its life-sup-

port system and rolling the head around on top of the gurney. It's a matte shot. We lined up the matte line with the horizontal surface of the gurney and shot the top half of the frame first. There was a hole cut in the gurney for Ed Phillips to stick his head through. Ed is a big man and if we simply laid him on the gurney his body would have stuck up and made the shot unconvincing. We shot the top half of the frame first and then backwound the film and shot the bottom half with just the orderly's feet showing through the gurney. Ed's head was there, but his body wasn't. It's a very convincing shot and the natural horizontal line of the gurney hides the matte line.

"There's a scene at the end of the film in which Mr. Fox's head is placed in a cubicle in a wall full of cubicles containing other heads. The front and back of each cubicle is glass and they are stacked right on top of each other, so you can see right through them and you can see that the bodies of the people in the top row are not there behind the cubicles on the bottom row. It's done with mirrors. We shot it on a sound stage at N.Y.U. We built a wall with the little glass cubicle windows in it. The actors who were on the bottom row simply sat down and poked their heads into the windows, since the wall was solid beneath them, there was no need to do anything special to make them look like disembodied heads, except to keep them low to the floor. The actors on the top row are directly over the bottom row. They were standing up and not really facing directly out the windows—they were shot through mirrors placed in the windows at a 45-degree angle from the front of the wall. Since you can see through the bottom row of cubicles and can't see the bodies of the actor's on the top row, the shot creates a very convincing illusion, even though it's a simple trick."

The film opens with a series of shots showing the thawing process. The frozen head—you don't know it's just a head until towards the end of the film—emerges from a vat of bubbling, steaming water. It's covered in plastic. "That was a very scary shot for Ed Phillips," Walter Pitt exposes. "We used an athletic jacuzzi and we put Ed in it. Ed was very patient and understanding. I told him, 'We're going to wrap your head in plastic for this shot and we want you to hold your breath, go under the water and rise very slowly.' It was a
(continued on page 40)

Fox, played by Ed Phillips, makes the horrible discovery that he is merely a head attached to a life-support machine.

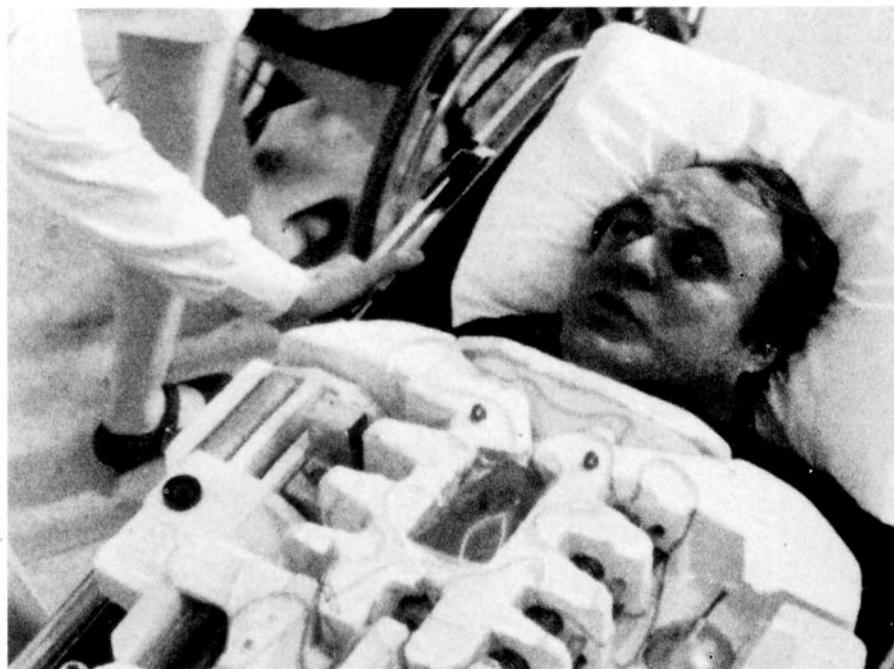

Friendly Plastic

By JOHN DODS

Fighting the clock with tooth and nail.



Friendly Plastic comes packaged in this very friendly looking 1¼-pound container for \$25. A 4.4-ounce container is also available for \$15.

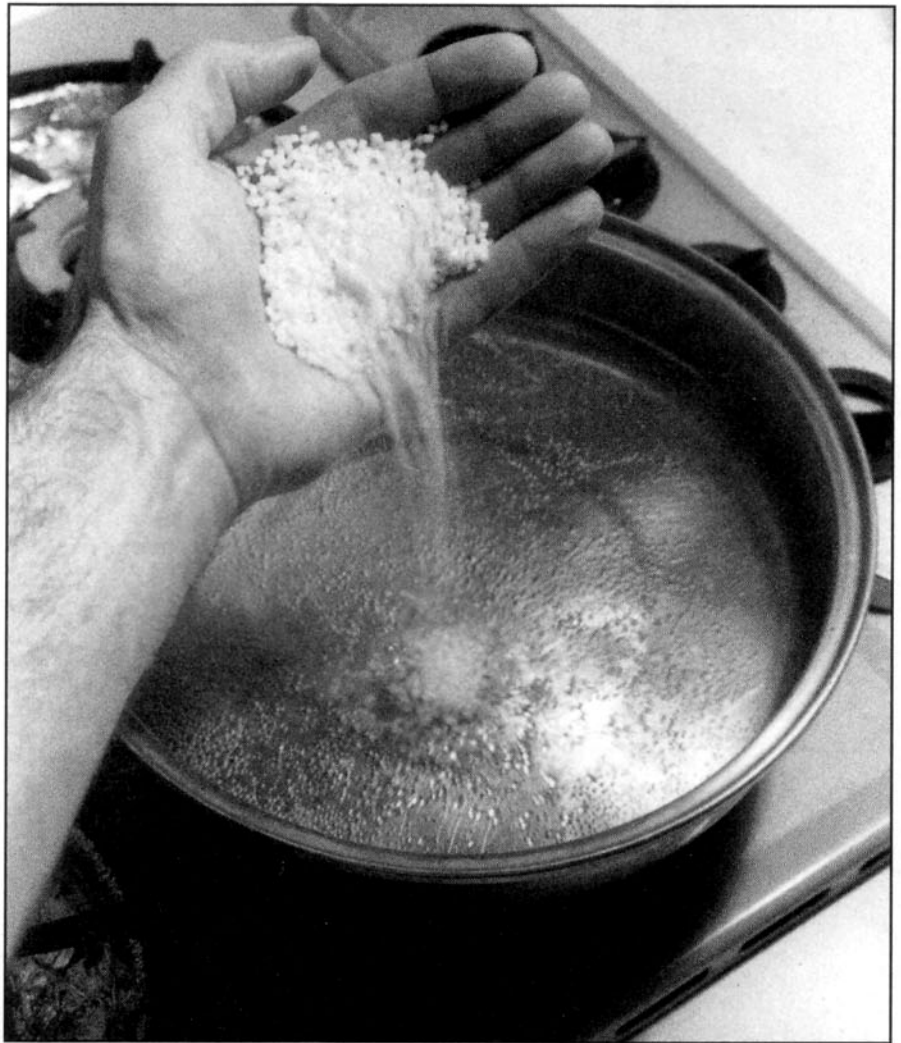

When Friendly Plastic is poured into hot water it turns into a clay-like, pliable material.

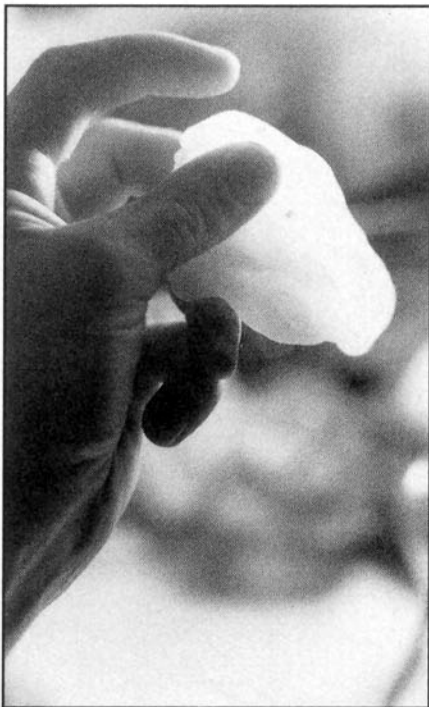

A piece of Friendly Plastic in its soft, pliable state. It remains workable for only 1½ minutes.

In two weeks!" That's when director/producer Fred Olen Ray was telling me he needed a disgusting rat-like creature to appear in his 35mm feature *Prison Ship*. I would usually take that long just to do a detailed sculpture, so I needed all the help I could find to get the job done *fast*. Help came in the form of Friendly Plastic.

Friendly Plastic is a modeling material which is hard until heated in hot water (135°F/60°C); then it turns into a clay-like, pliable material. While the plastic is soft, fingers and tools can be used to form it into teeth, nails, or any shape that can be sculpted in the short time the material remains workable—about 1½ minutes. As

Friendly Plastic cools, it hardens into a practically indestructible solid. It is somewhat flexible and does not crack or break easily. It can be drilled and carved with tools.

I used Friendly Plastic to make the teeth and nails for the deadly "Jager-rat." This took minutes compared to the days I would typically need to make teeth of dental acrylic cast from latex molds of Sculpey tooth forms. I attached the Friendly Plastic teeth directly to the model's foam-rubber mouth with Super Glue.

Detailed sculptures are difficult to make because of the short time that the plastic remains workable; this can,

however, be extended by periodically holding the work in progress under hot running water. A heat-gun can be very useful on larger projects for heating areas of the sculpture onto which additional plastic is going to be applied. Friendly plastic is white in its natural form; you can paint the cooled material with most solvent-based paints including spray paints and model paints; it can be colored with permanent-type felt-tip marking pens or dyed by soaking it in cool fabric dye overnight. Other adhesives that bond to Friendly Plastic are epoxy, model cement, and silicone bathtub glue.

CAUTION: The label on my container of Friendly Plastic says: "NONTOXIC: ingestion may cause nausea but no harmful effects are expected." The Friendly Plastic Company plainly didn't see the contradiction in their phrasing; nausea is a toxic effect. In general, however, Friendly Plastic appears to be an unusually safe material. John Kay of the Friendly Plastic Company told me that if their material is being "dry heated" (heated in an oven, or with a heat gun) for "extended" periods, the work should be done in a ventilated area. This means: do this kind of work out of doors unless you have a professional ventilation system.

Friendly Plastic isn't cheap but it is reusable. It costs \$15 for 4.4 ounces or \$25 for 1 3/4 pounds (a 1 1/2 quart volume). For further information contact Friendly Plastic Co., 2888 Bluff St. #233, Boulder, CO 80281, Tel. (303)530-5115.

CM

Use an ordinary kitchen knife to stir the Friendly Plastic into the hot water.



A tooth or claw can be made out of Friendly Plastic in a matter of minutes. It would take days to make a similar claw out of dental acrylic, because you would first have to sculpt it in clay and then make a mold.



PHOTO: JOHN DODS



PRESERVATION!

Protect your precious copies of CINEMAGIC, while keeping them on hand for easy reference in custom-crafted leatherette file cases or magazine binders embossed in gold with the CINEMAGIC logo. These handsome cases enable you to slip your copies of CINEMAGIC in-and-out individually, while the metal rod binders hold your copies of CINEMAGIC together, intact, like a large book, allowing you to leaf through issue after issue in chronological order. Each binder or case holds two year's issues!

Library Cases: \$7.95 each, 3 for \$21.95 & 6 for \$39.95 Postpaid.

Binders: \$9.95 each, 3 for \$27.95 and 6 for \$52.95 Postpaid.

U.S.A. ORDERS ONLY—Satisfaction guaranteed or money gladly refunded. Please allow 4 to 6 weeks for delivery.

Mail order to and make checks payable to: Jesse Jones Box Corp., P.O. Box 5120, Phila., PA 19141.

Foreign Orders: Add \$2.50 per unit for additional postage and handling outside the U.S.A. Prepayment must be in US funds only.

SUBSCRIBER SERVICES

Missing copies? Moving? Renewals? Receiving duplicate issues? Questions about your subscription? Write directly to:

CINEMAGIC

Subscriber Services,
P.O. Box 142
Mt. Morris,
IL 61054

NEW SUBSCRIBERS ONLY:

Do not send money and order to the above address. See subscription ad elsewhere in this issue.

Label Goes Here

Subscription inquiries addressed to the editorial offices will only delay your request.

NAME _____
ADDRESS _____
CITY _____ STATE _____ ZIP _____



The shot in the beginning of *Mr. Fox* in which Fox's head is thawed out in water was dangerous to actor Ed Phillips.



The "body", with its blinking lights and tubes filled with moving colored liquids added production value to *Mr. Fox*. It was built by artist Tyler Smith.



Fox discovers that he's nothing but a head attached to a machine when he sees himself reflected in a hospital elevator ceiling.



Fox smokes his first cigarette after being brought back from a death caused by lung cancer. Only his head could be saved.

PHOTOS: COURTESY OF WALTER PITT

Mr. Fox

(continued from page 37)

very dangerous situation because the jacuzzi was surrounded with movie lights and one could have fallen in and electrocuted him. He was a real trouper, he let us do several takes before he couldn't stand it any more."

The life-support machine—which Pitt calls the "body"—is a very elaborate device with blinking lights and tubes full of flowing, colored liquids. The presence of the "body" in the film raises the production values to a very high level and helps make *Mr. Fox* look like a production done on a sizeable budget.

"The body was built by an artist named Tyler Smith, and it was one of the aspects of the production that I actually had to pay for," Pitt continues. "Tyler has his own distinctive style, which worked very well for our purposes. There was one time when the body shorted out with Ed Phillips in it—which Ed didn't appreciate too much. It was another hazard Ed had to endure to play Mr. Fox. I was very lucky to have so many talented people working on my film for little or no money. *Mr. Fox* was done as a student film for a budget of \$12,000. If I actually had to pay everyone involved it would have cost at least five times that much. Ed Phillips and Bill Tunnicliffe would get up with me a dawn on the days we were shooting, help load the

equipment into the van and spend long days on the set—and I couldn't afford to really pay them for their efforts. Their devotion to the project was incredible and it would have been impossible to make *Mr. Fox* without that kind of support. Ed has gotten acting jobs as a result of *Mr. Fox*, so his devotion at least paid off for him in the long run.

"Actors are really taking a big chance when they sign on to do a student film—they are committing their time and talent in the hopes that the film will be worth showing around to casting people on larger projects—they're also hoping that you will make it big someday and remember the sacrifices they made for your early work. The principal actors in *Mr. Fox*: Ed Phillips, Gene Borio (who played the orderly), and Gustav Vintas (who played the psychiatrist), were all terrific—especially Ed. Casting a student film is usually very difficult, I was lucky to find the right actors to fill the roles in *Mr. Fox*.

"I spent one month writing *Welcome Back Mr. Fox*," Pitt reveals. "We had two shooting schedules. We spent about two-and-a-half weeks in the fall shooting most of the principal photography, and then we shot one week of pick-ups in the spring. I don't believe in shooting a film in dribs and drabs—it isn't fair to the actors and other people who are contributing their time to force them into a shooting schedule like that. I think you should have enough money to shoot the entire film,

and then—if necessary—go out and get more money for post production. *Mr. Fox* cost \$12,000, most of which came out of my own pocket. I worked odd jobs while I went to school to finance the project. I also got a \$2,500 grant from the Louis B. Meyer Foundation, but about half of that money went towards paying my tuition.

"I now have a partner, Randy Lippert, and we have formed our own production company. We have several projects in the works. We just finished shooting a 45-minute documentary about the fashion modeling business for the Learning Annex in New York. It focuses on the Elite modeling agency. We shot it in New York and West Palm Beach, Florida. I'm also currently writing a feature film which Randy and I are looking for backing for. We hope to start shooting this coming fall. I'm interested in mixed medias and I like the idea of shooting on film and editing on video, so I'm looking to shoot some rock videos. We have lots of 'irons in the fire.'

Director Walter Pitt and his partner Randy Lippert, who is a producer, have big plans for the future. *Welcome Back Mr. Fox* is currently serving as an impressive demo reel that proves they can do big things. *Welcome Back Mr. Fox* is being distributed on TV, film festivals, local cable stations and the American film market by I.F.X. (The International Film Exchange)—watch for it. You will undoubtedly be seeing more work from these talented filmmakers in the future.

Test Driving Back to the Future

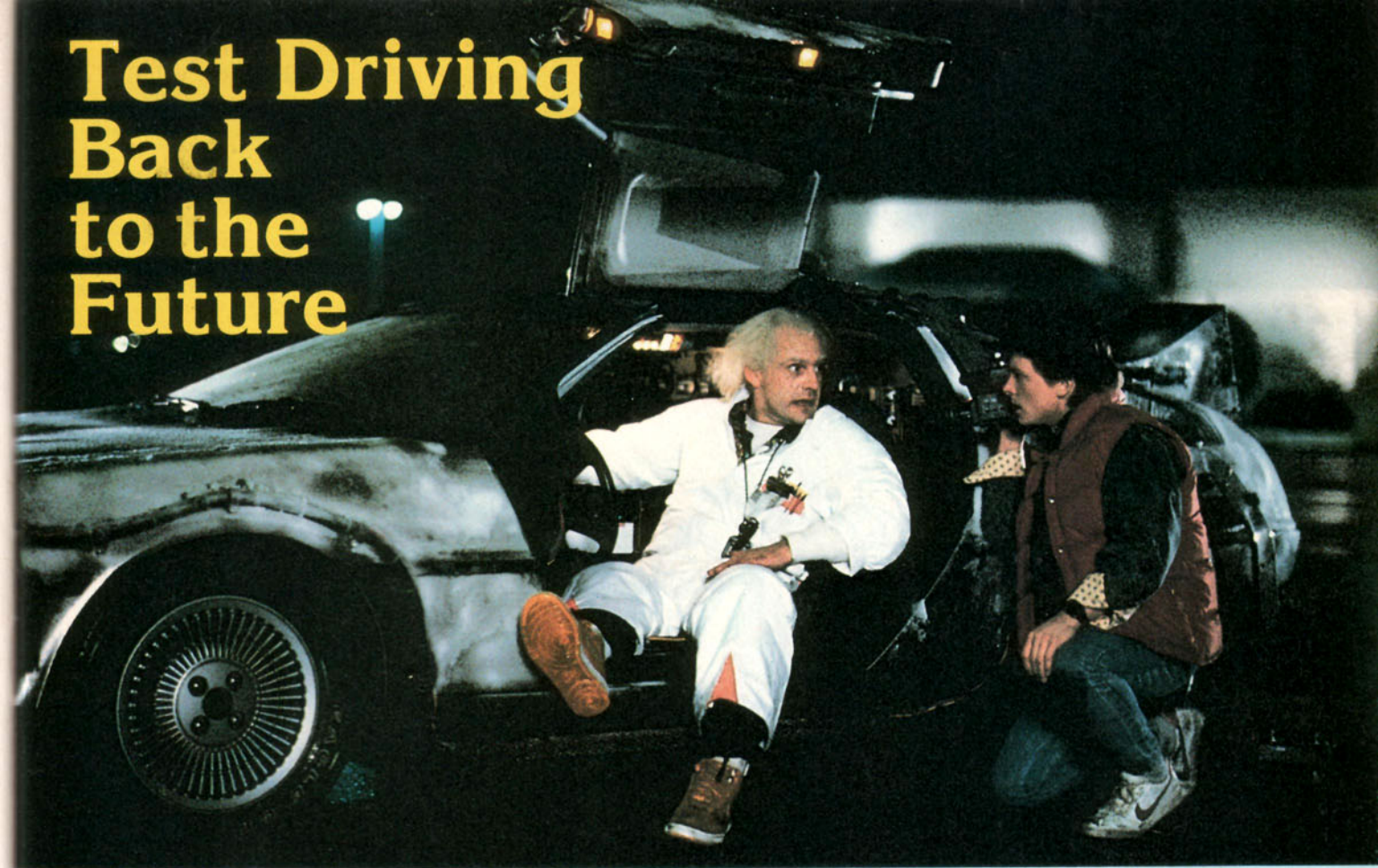

PHOTO: © 1985 UNIVERSAL CITY STUDIOS, INC.

Time travel is one of the staples of science fiction. Every writer from Mark Twain to Robert Heinlein has explored the possibilities. When time travel comes to the screen, designers have a field day creating contraptions that will become time machines. Over the years dozens of time machines have been built for the movies. They've taken almost every shape imaginable—everything from ornately elegant 19th century barber chairs to awesome chrome and plastic sculptures. For the 1985 hit movie *Back to the Future*, writers Robert Zemeckis and Bob Gale envisioned a shiny stainless steel DeLorean as the basis for their time machine.

The original design work was done by conceptual artist Ron Cobb, whose work has been seen in many SF pictures including *Close Encounters* and *ALIENS*. Cobb worked up very complete designs for both the inside and outside of Dr. Emmett Brown's DeLorean time machine, but was forced to go onto other projects before *Back to the Future* actually went into full production.

The producers wanted to see some more design variations on the DeLorean, so they turned to their own storyboard artist and production illustrator, Andrew Probert, for the task. Conceptual design is nothing new for Probert who spent a good deal of time re-designing the *Enterprise* for *Star Trek—The Motion Picture* and designing TV's *Airwolf* helicopter, inside and out, among other credits.

Artist Andrew Probert shows off some of the DeLorean designs that were created for the hit time travel movie.

By DAVID HUTCHISON

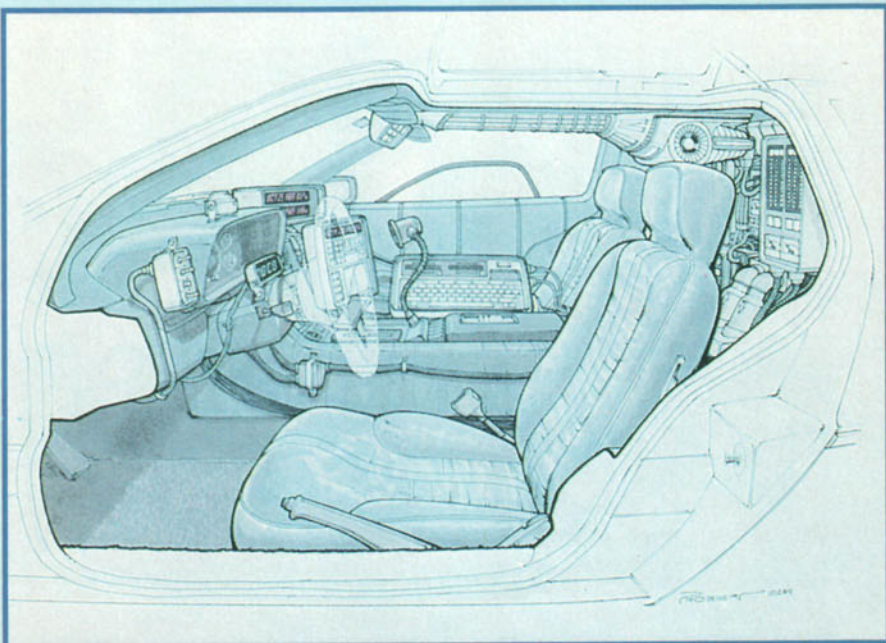

ART: ANDREW PROBERT



Above: Marty crashes into the barn. Below: Design concepts.

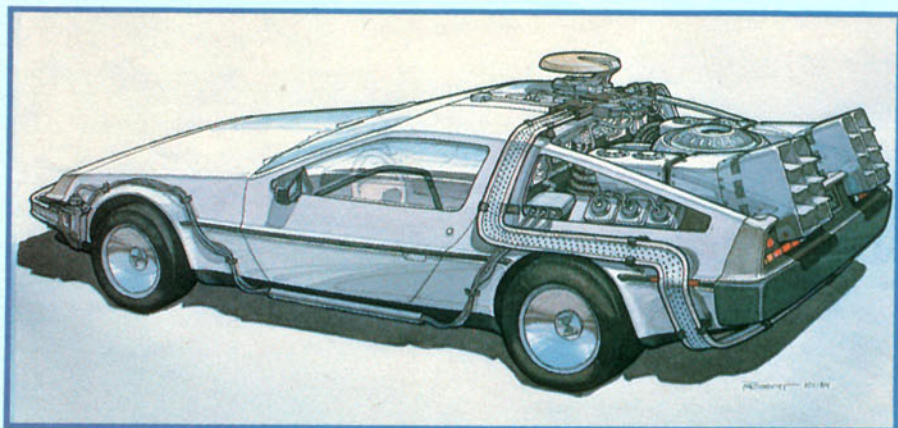
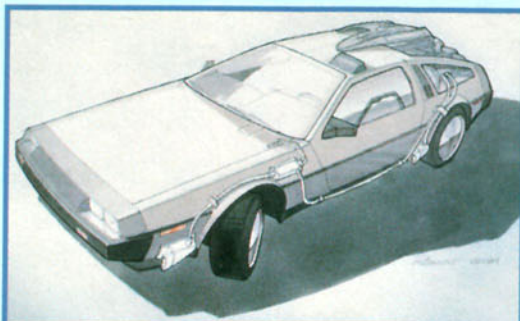
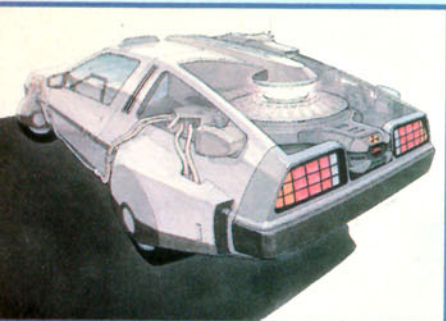

"I went to Arts Center and majored in Industrial Design," explains Probert, "so the project was a natural for me. The producers wanted me to produce some variations and update what Ron Cobb had started. Essentially, my big design con-

tribution was on the outside of the car. Even though Ron and I had done interior drawings, the final version was assembled by the Effects team."

Many times production art is used not so much as a literal plan as it is for inspira-

tion. The art suggests a direction, generates excitement and gets everyone working on the same wavelength. The final product may or may not end up looking like the original art. Usually, the spirit of the original art is maintained.

"Once a concept has been approved, it's up to the director, initially, and then the art director or production designer, to either use that as a springboard for an approximate feel or direction to go, or, if they love it, then they can come as close to it as possible, to the point of actually fabricating the various components. But, essentially these concept sketches are only to provide a feel, or a general orientation, for the various bits of detailing to be used.

"In this case, they went in a totally different direction," says Probert. "Most of what I had proposed for the interior were items that could be found at your local electronics store—keyboards, mini-computers, etc.

"The direction Rob Cobb took was still a found-parts situation, but his was more in the line of older hardware—airplane parts, you know, throttles, gauges, dials . . . that sort of thing. So, I think what the Effects Team came up with was sort of a happy medium between the two of us.

"The producers wanted the car to look like it was assembled not only on the inside but the outside, from bits and pieces of things the professor would be able to lay his hands on. In the original script, this

car was described as having wires and such taped and rivetted along the side of the car up to the front. As you know, the front is a trunk, so there was sort of an understood concept that there would be an additional power-supply up front: you know, generators or what-have-you. Now, Ron came up with the idea of the exterior coils that would create sort of a flux or time warp bubble. which was a great idea, because in my initial concepts I had just thought of the car as being in a stasis field or something that would be generated from within the car; he came up with the idea of a bubble being generated around the outside of the car. So, essentially, when he left the show, that was an idea that I wanted to hang onto. The director, Bob Zemeckis, thought it was a good idea as well, so that was one of the ideas that stayed. Visually, it works very well."

In addition to his storyboard and illustration chores, Probert created the *Tales from Space* comic book with the cover story "Space Zombies on Pluto."

"The comic book appears in the film right after Marty crashes through the barn and the Peabodys come out to investigate what's going on. They see this mysterious-looking vehicle, and then this guys steps out, in their eyes, wearing a spacesuit. The kid advises his Dad to shoot it, because it's from Pluto and it's going to fry his brain. To prove his theory, he shows his Dad this comic book. Dad looks at the comic, and then lowers it to reveal the car in a reasonably approximate position of the ship in the comic book.

"The comic was very heavily researched, to be as authentic as possible for the era. So, taking my cue from my research, I noted the illustrators' signatures were fairly large, so I put mine on the comic the same size. But when they shot the insert of Mr. Peabody's point-of-view, he had his thumb right on my name!" Probert sighs.



CM

Above: Probert's Comic cover. Below: Scene illustration.

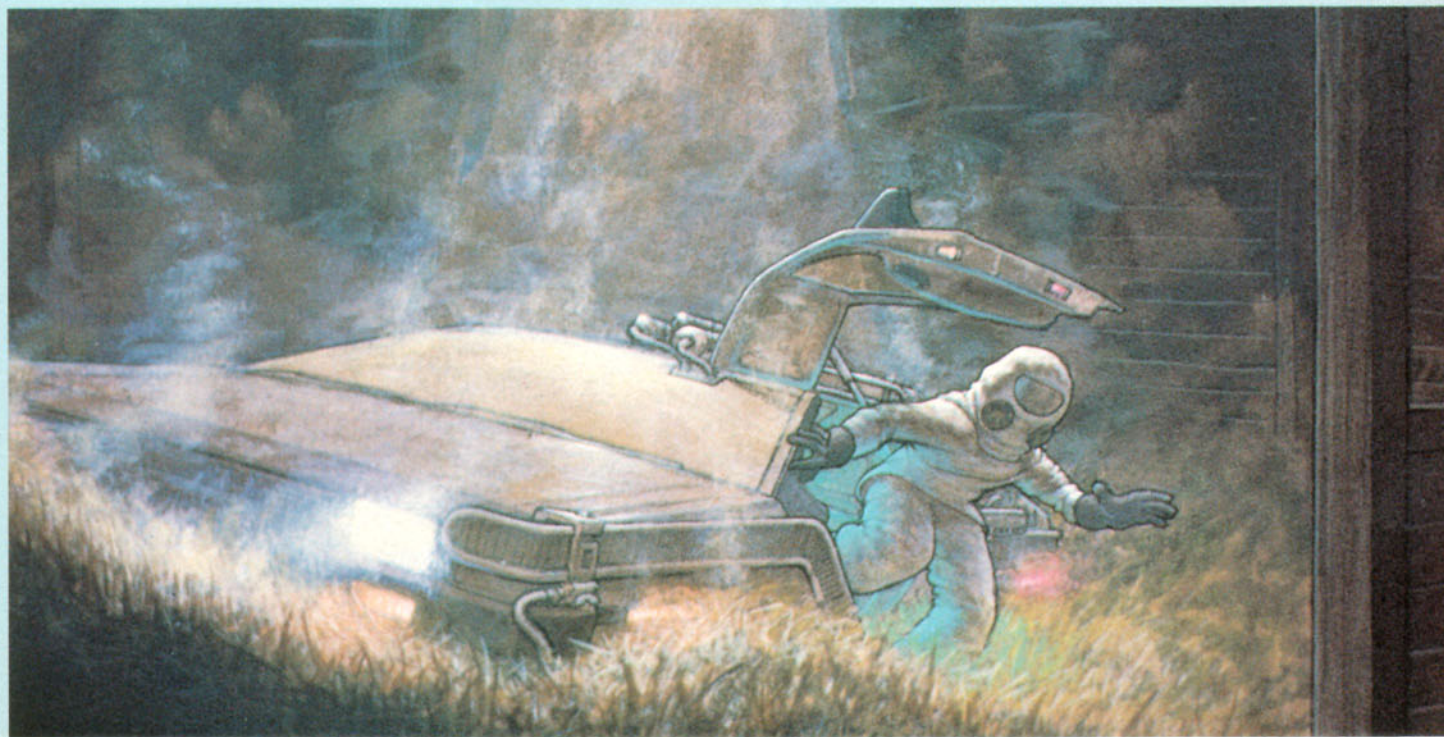

STARLOG

photo guidebooks

NEW!

SPECIAL EFFECTS, Vol. 4

Just published, this newest volume in the STARLOG Photo Guidebook series on Special Effects takes you into the magical realm of fantasy filmmaking. Detailed accounts of such films as *TRON*, *Raiders of the Lost Ark*, *Dragonslayer*, *E.T.*, *Something Wicked This Way Comes*, *Star Trek II*, *Dark Crystal* and *Poltergeist* are lavishly illustrated with page after page of photos (many in full color). Journey into the realm of pure imagination that is fantasy filmmaking at its best—new worlds, new creatures, ghosts, aliens and fire breathing dragons.

FANTASY EFFECTS!

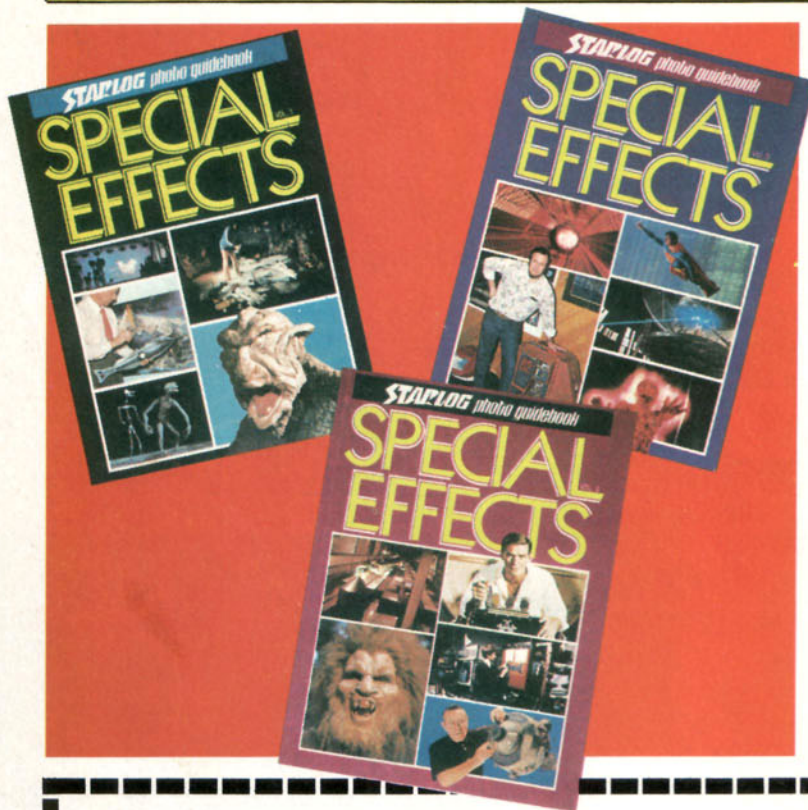
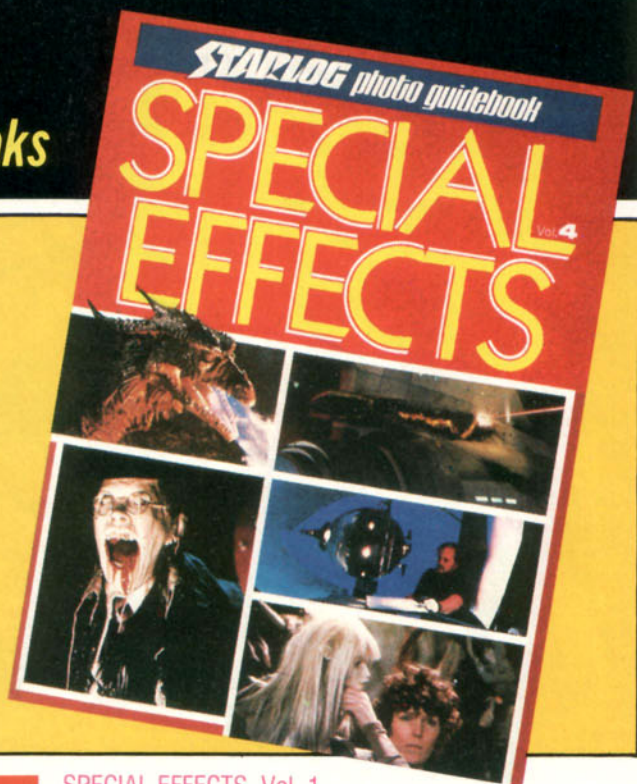

SPECIAL EFFECTS, Vol. 1

See the amazing world of miniatures and model animation—from *King Kong* to Ray Harryhausen and TV's *Land of the Lost*. Special blueprint section includes: the Nautilus from *20,000 Leagues Under The Sea*, Robby the Robot, the C-57D flying saucer from *Forbidden Planet*. Behind-the-scenes color photos from *Battlestar: Galactica*, *Space: 1999*, *The Lost Saucer* and SF classics like *Close Encounters*, *Flight To Mars*, *Thunderbirds*, *War of the Worlds*, *Star Trek*... more!

SPECIAL EFFECTS, Vol. 2

Exclusive interviews with masters of matte painting, effects, make-up and cel animation. A festival of effects films from space epics to splatter movies—pictured in color photos and technical diagrams. Special section on making the giant squid from Disney's *20,000 Leagues Under The Sea*, the Time Machine from George Pal's movie, and the Enterprise designs—from TV to theatrical. All this... plus more!

SPECIAL EFFECTS, Vol. 3

Take a trip into the gleaming world of modern film wonders—the technologies that create Hollywood's special effects for science fiction, horror and fantasy movies. Lavishly illustrated, this book explores computer animation, robot cameras and new optical processes. Journey behind the scenes of *Star Wars*, *Flash Gordon*, *ALIEN*, *The Empire Strikes Back*, *Altered States*, *The Black Hole*, TV's *Dr. Who*, *Cosmos*, and more! Discover the innerworkings of Doug Trumbull's new Showscan process and the double 70mm 3-D system.

Send to:
STARLOG GUIDEBOOKS
475 Park Avenue South
New York, NY 10016

Add postage to your order:

Total enclosed: \$ _____
NYS residents please add appropriate sales tax

Please allow 4 to 6 weeks for delivery of 3rd Class mail. First Class delivery usually takes 2 to 3 weeks.

Please make check payable to Starlog Press.

Name _____

Address _____

City _____ State _____ Zip _____

- ___ Vol. I \$8.95
- ___ Vol. II \$8.95
- ___ Vol. III \$8.95
- ___ Vol. IV \$9.95

Add postage for above:

- ___ 3rd class \$1.55 ea.
- ___ 1st class \$1.75 ea.
- ___ Foreign Air \$2.55 ea.

ORDER NOW!

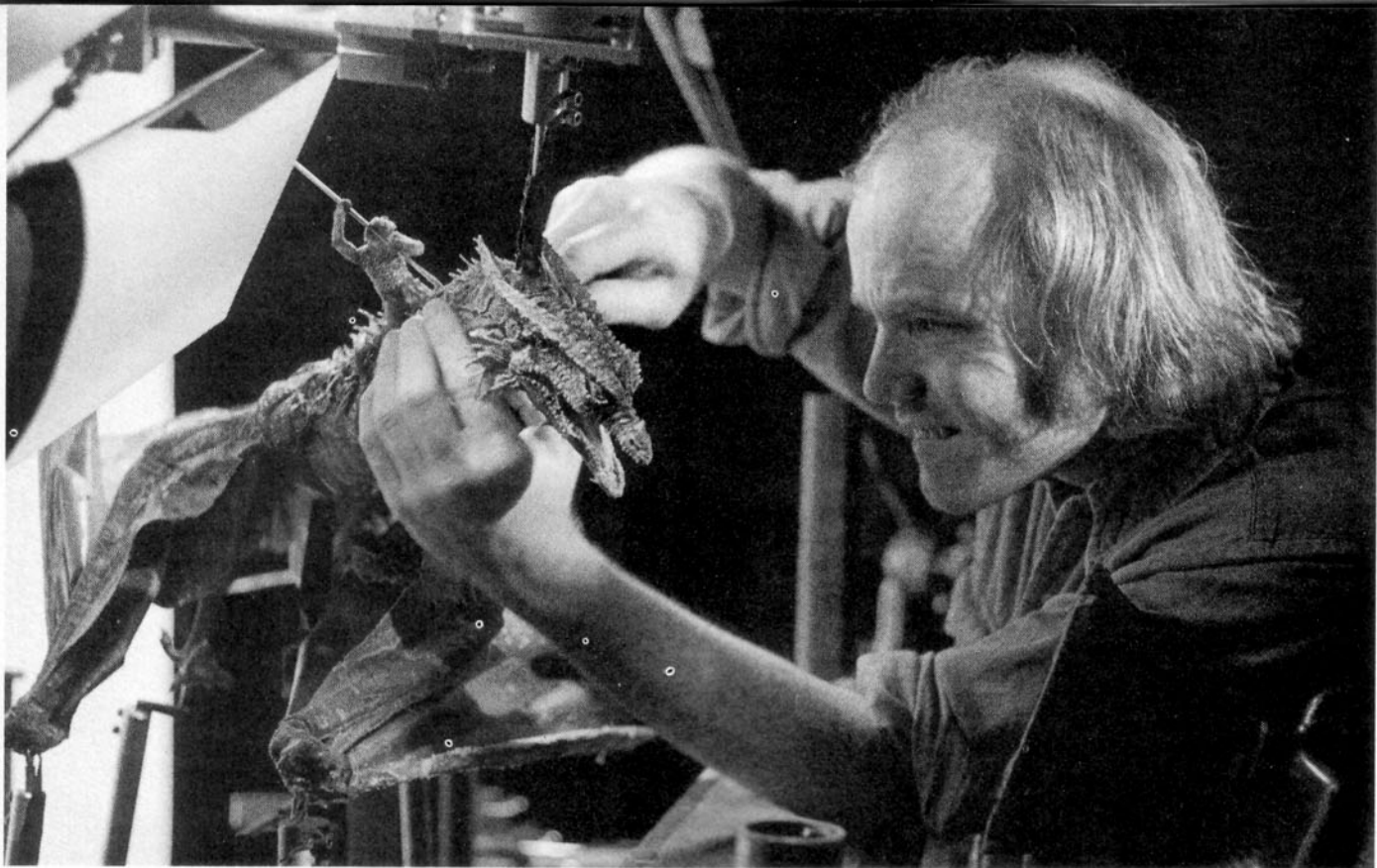

Phil Tippett works with the go-motion dragon at Industrial Light and Magic during the filming of *Dragonslayer*. The feet and head of the dragon are connected to motorized rods, but some small movements of the mouth and the figure are made with traditional stop-motion.

Stop-Motion With Style

Add a new dimension to your animation by recognizing and developing your own style.

By DOUGLAS BORTON

To some, it might seem strange to talk about style in relation to any area of special effects. Travelling mattes and process projection are simply techniques used to approximate reality as closely as possible; miniatures and even matte paintings are designed not for their artistic value but to supplement and match live-action footage.

But stop-motion animation is a technique of a different kind. At its best, it is used to create a performance—to breathe life into a model and let it interact with the live-action characters, almost as another member of the cast. Not all actors have a distinctive style, but the great ones usually do. The same is true of the animators who stand behind their creations' on-screen performances.

Let's look at some of the leading model animators and try to identify at least the major facets of their distinctively personal animation styles. Then we will consider how a young animator might learn to develop his or her own style, as one more step toward becoming a pro.

Willis O'Brien

Willis O'Brien was the pioneer in the use of model animation as a special-

effects technique. In his younger days, he tried a number of odd jobs, including ranch hand, boxer and cartoonist; when he turned to filmmaking his first efforts were animated short subjects featuring caricatured latex puppets of cavemen and dinosaurs. The elements of the cartoon—exaggeration, humor, and a certain roughness around the edges—found their way into all of O'Brien's animation, even that of his feature films. Those elements are the essence of his animation style.

O'Brien personally animated major portions of only two feature films, the silent *Lost World* and *King Kong*. In *King Kong* the strengths—and weaknesses—of his unique approach to animation are most readily apparent. Kong conveys a range of emotions unparalleled in a stop-motion creature: O'Brien invests the giant ape with elements of pathos, humor, nobility and horror. The animation is vigorous; the fight scenes, especially, capture an overpowering vitality, a rough-and-tumble wildness that makes most later animated brawls seem timid by comparison. O'Brien's fertile imagination

Jim Danforth animated the incredible Beetle Man from the rarely seen parody *Flesh Gordon*.



gave rise to an astounding variety of actions; in the battle with the tyrannosaurus, Kong first boxes with the dinosaur, then pulls it down by its leg, somersaults it onto its back, and finally mounts it to crack its jaws. O'Brien was an expert, as well, at providing small touches calculated to give each animal the illusion of life. The tyrannosaurus, entering the glen, pauses to scratch its ear; Kong, after killing the creature, lifts its head and lets it drop to make sure it is dead; sniffing Ann Darrow's dress, Kong's nostrils twitch and his brows furrow in bemusement.

Willis O'Brien was a master, and *King Kong* remains unquestionably the greatest stop-motion film and arguably still the screen's most awesome exercise in special effects. Nevertheless, O'Brien's work does have its faults. His animation, though powerful and even emotionally moving, is generally rough and jerky. Often, actions are speeded up beyond anything possible in reality. After being initially felled by Kong, the tyrannosaurus leaps to its feet in a split second; later, Kong climbs almost instantly onto the animal's back. Possibly O'Brien found the job of concealing the wires or support rods required for those actions so tedious that he simply rushed through them. Certainly the aerial-braced action in Kong's fight with the pterosaur is among the crudest animation in the film, and the animated portion of Kong's fall from the Empire State Building, where he finally lets go and drops away on wires, is also too fast. O'Brien's animation is further marred by a tendency to slip too rapidly into "held" or frozen poses and to maintain such poses too long, without enough incidental animation of the figure to fully maintain the illusion of life. This, too, may reflect a certain sloppiness on his part—the desire to expose as many frames as possible for the least effort.

The spectacular dinosaur roping sequence from Ray Harryhausen's *Valley of Gwangi*.

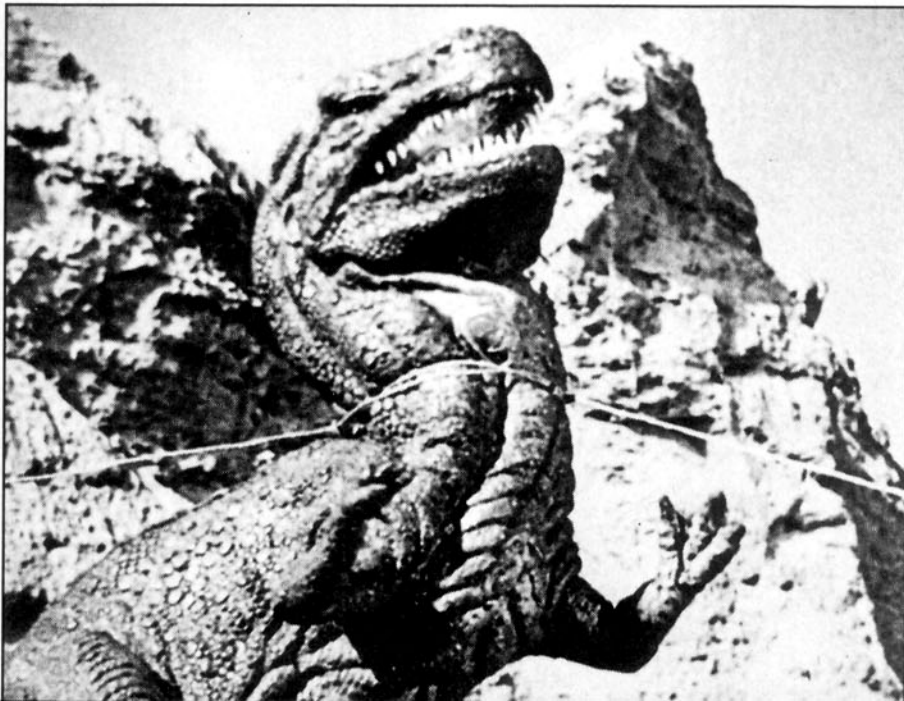

It is important to note, however, that much of the vitality and drama of O'Brien's animation actually stems from the very elements which can be criticized as sloppy. If it took the tyrannosaurus longer to get to its feet, or if it took Kong longer to mount the animal's back, the realism of the scene would improve but some of its frantic pace and energy would be lost. If the motion of Kong's arm throwing a punch were smoother and more natural, the punch itself would not have the same visual impact. When Kong, roaring, shakes his head or pounds his chest, the action is powerful in part *because* it is frenetic, strobing, even jerky. Smoother motion would have been more realistic but less exciting—and in a fantasy adventure, which of the two is more important?

Undoubtedly O'Brien wanted to achieve the most fluid action possible—but perhaps it is a good thing that he did not always succeed. Whatever was lost in photographic accuracy may have been gained in sheer power.

Ray Harryhausen

If O'Brien's work reflects some of the elements of the cartoon, that of his protégé Ray Harryhausen can be more aptly compared to the storybook illustration. In the mythological fantasies he loves best, Harryhausen has created a plethora of colorful, stylized beasts and brought them to life with dazzling artistry. In contrast to O'Brien's rough, loose animation, Harryhausen's work is clean, streamlined, deceptively simple, tightly controlled—and unerringly fluid. His style is most noteworthy for two key elements: characterization and economy of movement.

At their best, Harryhausen's models give virtuoso theatrical performances, replete with melodramatic gestures and facial expressions. The gentle but unpredictable Mighty Joe Young (largely ani-

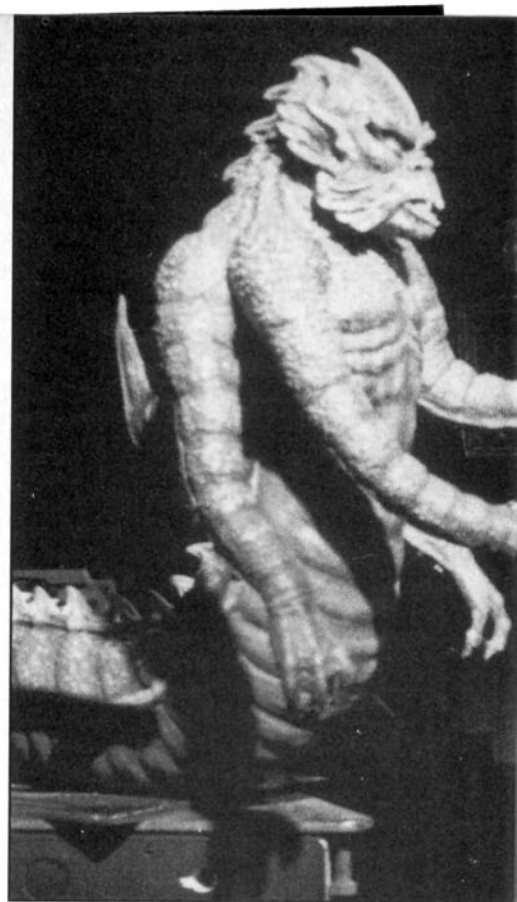

Ray Harryhausen in his London studio sets up a shot with the

mated by Harryhausen), the greedy, reclusive Cyclops of *The 7th Voyage of Sinbad*, and the scheming Calibos of *Clash of the Titans* are only three of the most obvious examples of Harryhausen's expertise in imparting character to inanimate miniatures. His non-humanoid creatures are almost equally memorable: the skittish, delicate Eohippus in *Valley of Gwangi*; the deadly, grinning skeletons which battle Sinbad and Jason; even the giant octopus of *It Came From Beneath The Sea*, with its immense glistening tentacle sightlessly probing the streets.

It is for good reason that Harryhausen is known as the dean of stop-motion animators. He is known, as well, as the fastest stop-motion animator who can turn out enormous quantities of footage in record time. Part of the explanation for this lies in his mastery of simplifying action—reducing a movement to its bare essentials, by which he reduces the amount of time and effort needed to reproduce the action frame by frame, while actually increasing its impact on screen. All animation, by its nature, requires such stylization to some degree; but Harryhausen has raised the stylization of his animation to the level, literally, of an art form.

The Cyclops remains the best example. Limited by time and budget, Harryhausen clearly devised a variety of ways to streamline the animal's actions wherever possible. In a conventional walk cycle, a human or humanoid being will swing its arms, an action difficult and time-consuming to animate. Harryhausen's Cyclops walks



Danforth and Allen

Jim Danforth, inspired by Ray Harryhausen, has developed a meticulous animation style with an emphasis on smooth, naturalistic action. Conventional stop-motion strobes unrealistically; to reduce or eliminate strobing, Danforth will double-expose (or quintuple-expose) key frames to simulate a blur, or painstakingly apply Vaseline to a sheet of glass before the camera to lightly obscure and blur a portion of the model.

Danforth's creations, in comparison to Harryhausen's, underplay their emotions and individuating traits—but definitely do display them. In *When Dinosaurs Ruled the Earth*, the hero shoots the mother dinosaur which has "adopted" his girlfriend; the dinosaur reluctantly draws back, then flicks its tongue. Later, the dinosaur appears when the hero and the girl are in danger; it picks up the girl, turns and leaves in one majestic, disdainful movement—leaving the hero behind. In *Flesh Gordon* the bizarre Beetleman fights by assuming a variety of karate-like poses, pincers snapping; as it closes in for the kill, its metallic wings beat in excitement.

By his own admission, Danforth works

stop motion model of the Kraken from his last film *Clash of the Titans*.

with its arms held stiffly, bent at the elbows with its menacing claws outstretched. The pose is at once less tedious to animate and more dramatic. The Cyclops walks swiftly—allowing the animator to speed it through the scene, while giving the finished action more energy. It is designed with goat-like legs which are both easier to animate than humanoid legs and more fantastic in appearance. It reserves most of its blinking, eye-rolling and lip-curling for the reaction shots, thus freeing the animator from concentrating too much on these details in long shots and giving added shock value to the closer inserts. Generally the creature will pause in its walking in order to react, rather than reacting on the move—again simplifying the action while enhancing its theatricality. Held takes are used when possible; in one shot the Cyclops raises its head and roars in a totally static pose which lasts for what must be 20 frames before segueing effortlessly into the walk cycle once more.

None of this should be taken to imply that Harryhausen shuns work—only unnecessary work, which would detract from the crisp, streamlined action he prefers. He is, of course, an enormously dedicated and hard-working animator; the skeleton fight in *Jason and the Argonauts* and the roping sequence in *Valley of Gwangi* stand, with the Imperial Walker sequences in the last two *Star Wars* films, as the most complex model animation set-pieces ever attempted.

Tight, clean, economical and endlessly

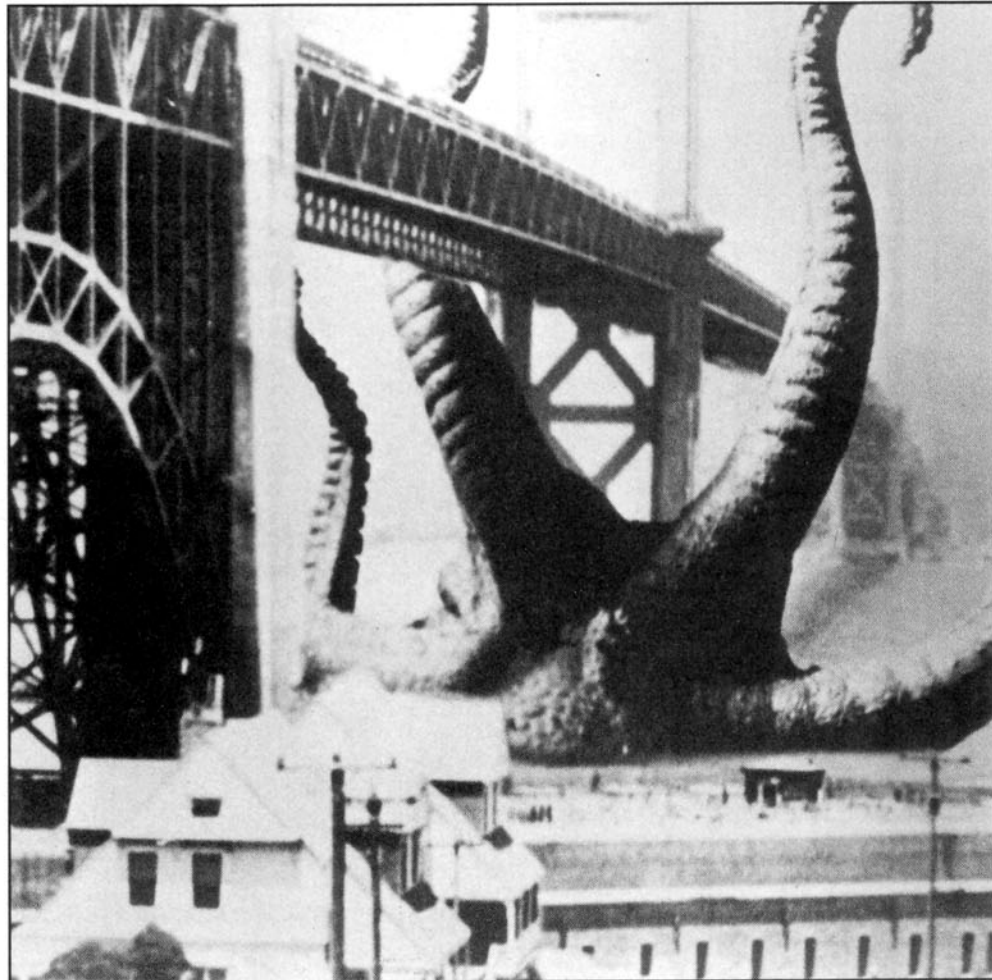

A giant octopus from Harryhausen's *It Came From Beneath the Sea* probes skyward with its glistening tentacles.



The powerful Cyclops from Harryhausen's magic *7th Voyage of Sinbad* gives a virtuoso performance of a tormented giant.

more slowly than Harryhausen, and perhaps partly for that reason he has not made as many films. But the work he has done—most notably *When Dinosaurs Ruled the Earth*, *Flesh Gordon's* Beetleman, Dioskilos, the two-headed hound of *Clash of the Titans*, and some shots of Pegasus in the same film—combines a flair for character which approaches that of Harryhausen and O'Brien with a subtlety of movement which surpasses anything else recorded in conventional stop-motion.

David Allen began his career with the rough but effective animation in the ultra-low-budget *Equinox*; later he founded the David Allen Studio, which has employed the talents of numerous animators. Most animators have assistants, but the David Allen Studio appears to be a true group effort, a fact which makes it virtually impossible to know which animator did any given shot. As a result the overall product, though of high quality, has an unavoidably homogenized look. But in Allen's solo efforts—and in the Studio's designs of the creatures and sequences, which Allen presumably directs—more of a personal style emerges.

Allen seems most intrigued with brisk, vigorous, hard-edged action reminiscent

of O'Brien's best work. He once remarked that he never limited—in fact, preferred—the strobing quality of most animation. His models, like those used by O'Brien, have an exaggerated, faintly cartoonish quality—the grotesquely proportioned *Equinox* ape creature, the lizard-like aliens in *Laserblast*, the various monsters built for *The Primevals*—and this quality carries over into the animation itself. It is not surprising that his award-winning Volkswagen commercial featuring King Kong was praised for its fidelity to the original, or that his *Equinox* ape recalls Kong even down to specific actions. When the ape picks up a man it has been chasing and flails him against the ground, it is Kong all over again—lashing out at those pesty natives or flinging the dying elasmosaurus to the floor of his cave.

Allen's tentacled monster in *Equinox*, with its coils strobing wildly, stands in sharp contrast to Danforth's plesiosaurus in *When Dinosaurs Ruled the Earth*, with its serpentine form blurring sensuously. It is the contrast between the raw power of a more refined O'Brien and the balletic grace of a more naturalistic Harryhausen.

ILM and Go-Motion

The most controversial model anima-

tors around are Phil Tippett, Dennis Muren and the high-tech wizards at Industrial Light and Magic. For *Dragonslayer* they developed a computerized approach to animation which they call Go-Motion. The idea is to eliminate strobing entirely by programming a computer to move the model, via concealed rods, during each single frame exposure—rather than moving the model by hand between exposures as is traditionally done.

How significant an innovation is this? It is possible to see a difference between the strobed action of an O'Brien, Harryhausen or Allen sequence and the smoothness of the ILM product. But personally I can detect no significant difference in smoothness between the Go-Motion shots and the best Danforth animation.

More important, smoothness is only one aspect of animation style. ILM has yet to prove that its computer-assisted animation is any better than hand animation at creating a memorable character, such as O'Brien's Kong or Harryhausen's Cyclops.

For *Dragonslayer*, the ILM effects team did create a memorable monster capable of expressing at least one emotion: rage. But how much of this is actually attributable to the animation? Consider the scene where the dragon discovers its slaughtered young. First, the Go-Motion dragon sees the carcasses and stops. The film then cuts to a shot of a hand puppet dragon head sniffing the bodies, followed by an extreme close-up on the hand puppet as the head slowly rises with an ominous growl. Next the film cuts to a long shot of a misty cavern, where we hear—but do not see—the dragon howling in fury. Finally the Go-Motion dragon lumbers out of the mist, executing its standard walk cycle. In this scene as in many others, the dragon's emotions are conveyed largely through the hand puppet, sound effects and editing. The animated footage, with only minor exceptions, contributes little to the animal's characterization.

At present, with major Go-Motion sequences limited to *Dragonslayer* and the mechanical walkers in *Return of the Jedi*, the most that can be said for the system is that, in skilled hands, it can provide pleasingly realistic motion. The models exhibit a sense of weight, mass and balance, which is difficult to achieve and shows considerable technical mastery on the animators' part. But despite its superb realism, the animation seems—to me, at least—emotionally empty and stylistically impersonal...spectacular but soulless.

Your Own Style

An animator's style reflects his own personality—the cheerful, vigorous roughness of Willis O'Brien, cartoonist, boxer, cowboy; the intense, controlled energy of Ray Harryhausen, the most prolific animator; the sense of grace and beauty shown by Jim Danforth, a meticulous perfect-

Animator Dave Allen created these creatures for his forthcoming film *The Primevals*. Allen's designs have an off-beat cartoonish look in contrast to the classical Harryhausen design.



ionist; or the tendency toward straightforward, dynamic action found in an animation purist, David Allen.

If you are an animator, you might ask yourself which of these styles most appeals to you. Even better, you might choose to disregard other people's approaches and develop your own original style—one that suits your unique personality and preferences. Do you have a quirky sense of humor—or a serious turn of mind? Do you prefer the beautiful and poetic—or the bizarre and shocking? Do you like realism or artifice—photographs or paintings? Do you like to get things done in a hurry—or are you only satisfied if you take your time?

Before you decide too quickly what type of person you are, you might try to see if there are any hidden sides of yourself that you can uncover. The creative process—including animation—is an excellent way to do this. Try new and

different approaches: see if they appeal to you or open up other possibilities that hadn't occurred to you before. If your tendency is to strive for the smoothest possible motion, do a shot that deliberately throws smoothness to the wind; free your mind and talent, at least temporarily, to concentrate on other things. If your subjects are always horrific or melodramatic, try something light, fun, even zany. Maybe you won't like it; maybe you will. Experiment, see what feels most comfortable, and ask yourself why.

As you develop your own style, you will probably find that it improves your animation, making it more distinctive, recognizable and interesting, by giving it a vital new dimension. The actions on the screen will no longer just be yours, they will be *you*. And when that happens, your animation—like that of O'Brien, Harryhausen, Danforth and Allen—will go beyond merely a skill or a craft, to become an art.

CM

Dave Allen's lizard aliens from *Laserbeat* had a very playful quality



BULLETIN BOARD



Please forward announcements of film projects in current production or near completion to Producers' Bulletin Board, c/o CINEMAGIC, 475 Park Avenue South, New York, NY 10016. Please include a photograph of some phase of the production if possible.

The Silver Scream. Horror/comedy anthology. Harry is a movie buff with an old projector set up in his basement. The projector shows its own horror films—which come off the screen and happen in real life! Producer/Director/Writer: Robert Tinnell. FX include: makeup, full-size interior dungeon and graveyard sets. 16mm, color, sound. Running time: about 15 minutes. (Robert Tinnell, 1356 N. Gardener, Apt. D, Los Angeles, CA 90046.)

Zippy the Pinhead. The Prequel is an animated film based upon Bill Griffith's offbeat underground comic book character. Zippy's adventures include Gumby, Rambo and Godzilla, and will be as strange as it sounds. Filming will be done in lower Manhattan for some live-action sequences. Animation includes clay-mation type characters, cut-out and xerox animation and hand puppets. Zippy will be filmed in Super-8 using an electronic flash lighting system to control color temperature and depth-of-field. (Kraftwork Productions, c/o T. Isoldi, 3770 Richmond Ave., Staten Island, NY 10312.)

Bloodless: A lurid vampire tale concerning migrating fruit flies that carry a cannibalistic virus. One man makes a living at destroying these vampires after U.S. infestation becomes large scale. A good friend of his, and scientist who is investigating the cause for these outbreaks of mass murder is put in the hospital by his girlfriend who is a vampire. He checks out of the hospital and takes it upon himself to kill the woman and then himself. After out bounty-hunter hero finds out about this he becomes no less than a human vampire killer. Writer/Producer/Director/Editor/FX: Matt S. Jaissle. Cast: Scott Allen, Tim Schoeff, Jay Allen, Richard Massey, Bob Ender. FX include: gun shot effects, deep chest scratches, a rotted corpse, hatchet in the arm, and half of a head blown away at close range. Filmed in and around Ann Arbor, Michigan. Super-8, color, sound on tape. Running time: 25 minutes. (Bluefilms, c/o Matt S. Jaissle, 211 Welch Street, Milan, MI 48160.)

A Bad Thing in Smallville. It's been five years since the brutal death of Sam Prentice, a demented gardener, and now he rises with the powers of the forest to take his gory revenge. Four teenagers, Kristen, Scott, Mark, and Rose, fall prey to Sam's wrath. As the hunt progresses, Rose discovers the secrets behind the killer and quickly plans his death. Highlights include a powerful love scene and the decomposition of Sammy Prentice. Produced by Nightdream Associates. Writer/Director: Brian Riley. Camera: Phil Rutledge. Special Makeup FX: Brian Riley. Cast: Allison Grewcock, Brian Riley, Ralph Reda, Johna Devin as Rose, and David Zukor as Sam Prentice. FX include: blood and gore effects, crumbling walls, and a complete, seven-piece makeup for Prentice. Running time: about 25 minutes. 8mm to video. Nearing Completion. (Nightdream Associates, c/o Brian Riley, 3 Blakeman Dr., Monroe, CT 06468.)

The Tomb. Veteran low-budget director, Fred Olen Ray (*Scalps, Biohazard*), is currently wrapping up post-production on *The Tomb*, a supernatural action adventure film that is Ray's most ambitious effort to date. *The Tomb* boasts a cast of stalwart talent including horror veteran, John Carradine, the versatile Cameron Mitchell, Russ Meyer's former protege Kitten Natividad, former '40's serial star, Carol Foreman (*Superman, Black Hawk*) and the unheralded "Queen of the B's," Sybil Danning. Rounding out the cast are Michele Bauer (*Terror on Tape*) as the evil demon goddess, Nefratis, and David O'Hara (*Biohazard*) and Susan Stokely, (*The Power*).

The film features a variety of elements ranging from desert chases and gun battles to horrible events in ancient Egyptian crypts to upbeat rock-and-roll production numbers. The quirky humor of director Ray is also evident throughout the film and the resulting combination of all of the above makes for one of the most offbeat fantasy films in recent years.

Special effects make-up is provided by Makeup Effects Lab (*Friday the 13th—3D*). Optical effects are by Bret Mixon who handled the same duty on *Biohazard*.

Ray's company, VFI, is well on its way to becoming one of the most prolific in town with *Dark Universe, Commandroid*, and *Blood Relatives* on the slate before the year's end as well as *Prison Ship* which Ray is currently shooting in Hollywood. (Viking Films International, Inc., P.O. Box 3563, Van Nuys, CA 91407.)



Rose Colored Glasses. Howie Barbidian is a teenager who wants nothing more than to be accepted by his friends, his family and his dog "Bob." His dreams come true when he stumbles upon a magical pair of rose colored glasses. Howie discovers that life's problems seem to disappear while viewing the world through rose colored glasses. There's just one catch—reality! Producer: Daniel R. Keseloff. Director: John Lawrence. Story: Tim Minear. Screenplay: John Lawrence. Music: Arron Hallas. Makeup: Jennifer Morrow. Cast: Daniel R. Keseloff, Maria O'Neal, Jerry Pokracki and Oreo as "Bob the dog." Super-8, color, dual-track sound. Running time: 25 minutes. (Timeless Entertainment, c/o John Lawrence, 5808 Washington Ave., Whittier, CA 90601 213-696-0945.)



The Mr. Bubble Series. Part One: Attack of the Killer Mr. Bubble. This girl is scared of bubble bath; a fear of Mr. Bubble she has had since a young child. This time when she takes a bubble bath, the soap bubbles incarnate into the real Mr. Bubble. Obsessed with fulfilling the girl's irrational fear of him, Mr. Bubble holds a small lottery—which he cheats at by making the chips all of the same number. Mr. Bubble tells the girl her number is up. With a knife in hand and the look of murder in his eyes, Mr. Bubble begins his essay of murder. The girl tries to out-smart the bubble-gone-maniac, but Mr. Bubble ends up out-smarting the girl by playing a game of hide and seek. But the girl reasons that Mr. Bubble is just that—a bubble. She proves her point, in a literal way, and the killer Mr. Bubble again takes on his less hostile form—foam. And once again peace is brought upon the bath tub. This film is an exaggeration of my sister's fear of bubble bath. Six part series. Film by Douglas T. Hawotte; Original film score by Andrew Pettersson. Introducing Melissa Buford. Mr. Bubble operated by Crystal Buford. Makeup by Paula Buford. Super-8, sound, color. Running time: 21 minutes. \$100.00 budget. (United Partnerships in Film and Communications, c/o Douglas T. Hawotte, 2312 8 Street Silvis, IL 61282.)

Dreamstate. A boy is brought to another world of magic sorcery, creatures of all sorts, and Satan himself. It eventually turns out to be a dream—I think! Producer/Director/Writer: Frank Cuomo and Tommy DeVita. Cast: Tommy DeVita, Frank Cuomo, Kirk Caliendo and many creatures. FX include: a full-size mechanical skeleton, a hand through someone's stomach, a spike through someone's head, a stake through someone's stomach, a decapitation and more. Video tape with sound. Running time: about 15 minutes. (Deco Productions, c/o Frank Cuomo, 133-48 118th St. South, Ozone Park, NY 11420.)

Adventure. A film about a man who is an adventurer and explorer, who has lots of adventures. Producer/Director/Writer/Cameraman: Eddie Ryder. FX: Stop-motion animation and stunts. Super-8, color, sound on separate cassette. (Transfilm Pictures, c/o Eddie Ryder, Hawthorne Hill Rd., Newtown, CT 06470.)

Theatre of Pain Muffy, a typical suburban cheerleader, is shocked and terrified to find out that her brother and his Death Punk friends don't just believe in Satan—they worship him. They even start sacrificing neighbor's dogs and cats to their god for fun. Fun becomes terror when the group's leader (who goes by the name of Lucifer) decides to sacrifice a virgin—Muffy! Producer/Director: William Cate. Writers: Glen Gordon and William Cate. Cast: CeCe Gulicho, Glen Gordon, Tyna Oft, John Gallagher, William Cate and Cecel Hay as Lucifer. A Unicorn Pictures presentation. Super-8, color, sound. Running time: 30 minutes. (Unicorn Pictures, c/o William Cate, 69 Princeton Rd., Arlington, MA 02174.)

Nightmare (nit'mar)—n. 1) A very dreadful dream. n. 2) A Gary Waxler Production starring Beth Ball, Chrissie Olson, Brian Price, Julie Price, Mike Salewski, Chris Sherman, and Robert Tozier. Coming home from a party, three couples must abandon their car on a dark gravel road and reach shelter quickly in order to avoid being hit by an oncoming storm. Their first mistake is entering a mysteriously opened house in which the owner doesn't appear to be around (at least, only to them he doesn't seem to be around!). Their next mistakes cost most of them their lives. Written/Produced/Directed by Gary Waxler. Super-8, sound, color, and 1/2 inch video by Pat Ryan and Gary Waxler. Assistant: Rich Springett. Edited by Alan Knight and Gary Waxler. Running time: 30 minutes. In production. (Gary Waxler Productions, 6409 Kilkenny Lane, Fairfax Station, VA 22039.)

Crystal Dawn. Derik Strand was on another routine surveillance mission in his SR-71 Blackbird. He never asked for an adventure beyond his dreams, but he got it. Young Strand and his aircraft are drawn into a vortex where Strand finds himself in a strange tower, lying beside a suit of armour and a sword whose blade is cut from a single white crystal. Strand dons the sword and armour and sets out to explore this strange land. In his travels he meets a vindictive fire breathing dragon, the bridge keeper and a large creature within a cavern. Strand finds himself finally within a crypt inside a volcano. Within the crypt Derik meets a being of awesome sorcery. Strand manages to slay this wizardous creature and escape the mountain before it blows apart. An Imagineering Films Production. Director/Writer/Producer/FX: Brad Hruboska. Cast: Brad Hruboska and Cam Haygarth. FX include: Rear-projected stop-motion sequences, live and animated combined footage, miniature flight sequences using actual aerial footage rear projected, beamsplitter glows, pyrotechnics, blood effects, latex masks, articulated mechanical monster head and numerous special sound and lighting effects. Shot on half-inch in video and Super-8, color. Running time: eight minutes with sound effects, music and narration post-dubbed. Transferred to half-inch video. (Imagineering Films, c/o Brad Hruboska, 266 Lakeview Ave., Burlington Ontario, Canada L7N 1Y6.)



BULLETIN BOARD

Daylight Burial. A small mid-western town encounters an electrical storm. The storm causes a nuclear power plant to discharge thousands of volts into the ground. The corpses in a nearby cemetery are suddenly brought back to life and terrorize the neighboring town. This film is drenched with exciting special effects and morbid murders. A must for horror fans. The special-effects makeup is done by Rob Hinderstein. Sets designed and constructed by Sean Murdoch. A Hinderstein/Murdoch Production. (Robert Hinderstein, 2413 El Alameda, Palm Springs, CA 92262.)



Saps in Space. Slightly offensive film about college kids who steal a spaceship and search for the perfect planet. Writer/Director/FX: Kevin Orban. Cast: Ken Orban and Richard Hauge. FX include: models and rear projection. Super-8, color, cassette sound. Running time: about 15 minutes. (Arena Films, Bottom of Barrel Productions, c/o Kevin Orban, RD#4, Box 355 Riva Avenue, North Brunswick, NJ 08902.)

If A God Should Fail. Hercules is ordered to Earth by his father, the great god Zeus. His mission: to stop the murderous rampage of a killer Cyborg. Plenty of action and stunt work. Producer/Director/Writer: Gary Whitson. Cast: John Whitson, Brad Whitson, Gary Whitson, Dom Pino and Sandy Whitson. FX include: crashing through a wall, jumping off a cliff and more. Super-8, color, transferred to videotape with a synchronized soundtrack. (Whitson Productions, c/o Gary Whitson, RD#4, Box 207, Dealtown Rd., Elmer, NJ 08318.)

Shadowplay. A 35mm feature-anthology film in the vein of *Cats Eye*, *Creepshow*, and *Nightmares*. We are looking to contact talented filmmakers, writers, FX people, artists, composers, etc. who want to be involved in making movies but don't know how to "break into the business." Send Resumes, photos of your work, letters describing your talents and qualifications, etc. to: (TAK Productions Inc., 443 First Street, Palisades Park, NJ, 07650.)

Details At Eleven. In this surrealistic production, the viewer finds himself engrossed in the deadly plot and sitting on the edge of his chair until the bizarre and climatic ending. Filmed in Super-8, color, and transferable to video (VHS-BETA). Produced by Antares Cinema. Written and directed by Kay Falconer. Running time 20 minutes. (Antares Cinema Creations, c/o office of G.S. Turner, South East 305 Dexter Street, Pullman, WA 99163.)

Delta Force. In the wake of the political assassinations of the American ambassador to East Germany and six of his aides by a terrorist organization, the President of the United States has assigned the Delta Force to their most covert and deadly mission ever. A team of five men, chosen specifically for their abilities in the special forces, will infiltrate the socialist republic of Yugoslavia (a suspected location for the terrorists' secret base) to seek out the terrorists and eliminate them. Producer: Rob Martin for Dark Harvest Productions. Director: Shaun Sullivan. Writer: Bob Lucius. Editor: Ron Zimmerman. Sound: Ron Zimmerman and Stephen Lamarre. Cast: Bob Lucius, Rob Martin, Roger LaRose, Danny Thompson and Jim Barzik. FX include: pyrotechnics, stunts, fight scenes and fantastic locations. Super-8, color, sound (narration and music soundtrack). Running time: about 21 minutes. (Dark Harvest Productions, c/o Shaun Sullivan, 71 Jordan Rd., Chelmsford, MA 01863.)

No Greater Glory. Lydia Rutledge marries a British officer, Sir Brian Fitzroy, long before the outbreak of the American Revolutionary War. Once war becomes inevitable, Lydia, born an American and a patriot at heart, spys for the rebel cause but is discovered by her husband. Fitzroy has only two choices: one, to bring her to trial which will result in his death; or two, let her go which will result in his downfall. He loves his wife and his family and hopes desperately that Lydia will reach the safety of the camp of her brother, an American General, before Fitzroy's cavalry can catch her. But will she? 16mm color, sound film. The film ends with a climactic battle with over 1000 extras! Running time: 65 min. A Reflection Productions Film. Producer: Thomas E. Miller. Director: Chris A. Heckman. Cast: Ken Siegel, Lynn Montuori, Russ Greve. Cinematographers: Mike D'Elia & Ed Askinazi. Sound: John Palmaro & Peter Russell. (Reflection Productions, c/o Chris A. Heckman, 1885 Washington Avenue, Seaford, New York 11783. 516-728-2432.)



I Dare Ya! Two little girls dare a boy to ring the doorbell of a spooky house. And we know how dangerous *that* can be. Producer/Director: Rik Joel Carter. Director of Photography: Katherine Butler. Production Designer: John Jockinsen. Music: Bill Parclely. Makeup Effects: David Stennitt. Production Manager: Ruth P. Mulligan. Cast: Joseph Broumand, Kerry Rogers, Augusta O'Neill and Angela Rowe. 16mm, color. Running time: 4 minutes. (Center Cinema Enterprises, 11601 Walnut, Orange, CA 92668.)

Things That Go Bump in the Night!—Clay animated short subject. An animator's sculptures come to life after he goes to sleep and wreck havoc among themselves. Animated by Mike Salewski and Gary Waxler. Super-8, color, silent. Running time: about 3 minutes. Completed. (Gary Waxler Productions, 6409 Kilkeny Lane, Fairfax Station, VA, 22039)

FESTIVAL NEWS

Brussels Super-8

The Third Super-8 Fiction Festival has been organized this year by the Super-8 Workshop of Woluwe-Saint-Pierre under the aegis of the European Fiction Super-8 Union (Alliance Europeenne du Super-8 de Fiction). The Festival is open to all amateurs and non-professionals of any age. No more than two films per person may be entered and films should not exceed 30 minutes in length. The entry fee of 500 FB (Belgian Francs) should be paid by International postal order drawn in Belgian Francs for the Festival Super-8 de la Fiction-Bruxelles and addressed to the Secretariat

(001-1526860.59). This entry fee entitles one to free admittance for the judging sessions as well as the Gala evening.

Under the heading of fiction films are included all Super-8 films based on an allegory of any scenario, obviously including genre works, moody, humorous, animated pictures and cartoons. Not admissible are: reports, documentaries, travel films and filmed songs, unless they meet the criteria generally understood by the term "fiction."

Films should have a magnetic soundtrack and 1.5 meters of leader and trailer. Fees should be paid by August 31, 1986, but films may arrive as late as September 30, 1986. Address all inquiries to: Super-8 Fiction Festival, P.O. Box 12, B 1150 Brussels.

includes the production of a short film. For registration information and dates contact Guy at Super8 Sound, 95 Harvey St., Cambridge, MA 02140, (617) 876-5876.

CM

Film Festival Guide

September Deadline

Central Florida Film & Video Festival

C.F.F. & V.F.
6722 Edgewater Dr.
Orlando, FL 32810
Month Held: October
Location: Orlando, FL
Gauge of Film: Super-8, 16mm

October Deadlines

The Kinetic Image Film Festival

Kinetic Image Film Group
Box 11465
St. Petersburg, FL 33733
(813) 577-2086

Eligibility: Amateur and independently produced non-commercial films.
Awards: Cash prizes.
Month Held: October
Location: St. Petersburg, FL
Date Established: 1977
Gauge of Film: Super-8, 16mm

Short Film Search

The eighth annual CINEMAGIC Short Film Search has been announced by publisher Kerry O'Quinn. Copies of this year's rules and entry forms should have been printed by the time you read this. For your copy send a self addressed, stamped envelope (#10, long size) to: CINEMAGIC Rules, 215 Park Avenue South, New York, NY 10003.

Deadline for entries will be October 1, 1986 with the Festival screening scheduled for late November. All amateur and non-professional filmmakers are invited to submit entries in Super-8, 16mm or video. Entries can not exceed 20 minutes in length.

Super-8 Workshops

Phil Vigeant of Super8 Sound in Cambridge, MA, announces the latest in a series of workshops emphasizing the latest in Super-8 production, editing, and special effects techniques. These workshops are taught by the Super8 Sound Staff, who believe that Super-8 offers amateur and professional filmmakers the opportunity to make quality films at affordable prices.

A highlight of the workshops are the double system sessions, which include every aspect of production and post-production technique of double-system sound filmmaking. Extensive hands-on experience

MAKING A LATEX MONSTER MASK!

START WITH ARMATURE



SCULPT



MOLD



CAST



PAINT



AND, VOILA — MASK!

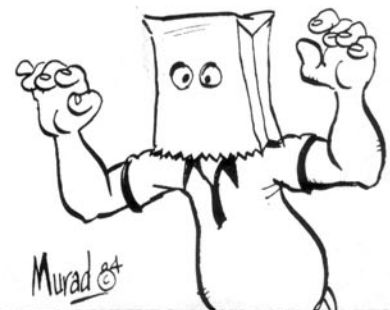

Murad et

GRIP KIT



Beaulieu 7008 PRO

For complete freedom and mobility in double-system filmmaking Beaulieu has built a professional model of the 7008, the 7008 PRO, with crystal-sync control. Crystal sync, preferred by professionals for its added flexibility, requires a crystal motor control in the camera and a quartz crystal oscillator (like that built into the Super8 Sound Recorder) in the tape recorder—but no umbilical cord.

With crystal sync, the cameraman is free to shoot from the best vantage point with no thought to the sound. The sound person can likewise pick the most desirable spot to record from, independent of the camera. There is no cable or other physical connection between the two. Great angles,

tight miking, no umbilical cord, and yet it is all in exact lip-sync with the accuracy of a quartz watch. The new Beaulieu 7008 PRO further enhances the professionalism of double-system Super 8.

The 7008 PRO has the same superlative features as the 7008S with the notable exception that it is a silent camera—though it will accept sound cartridges so that you can shoot striped film and transfer your sound for single-system projection without having to send your film off to a lab to be striped. The only other difference between the 7008S and the 7008 PRO is slow motion. The 7008S has speeds of 4, 9, 18, 24, 36, and 56 fps; the Pro gives you the additional option of shooting at an incredible 80 fps, instead of 56 fps.

Crystal Camera Control

The Super8 Sound Crystal Camera Control will match the speed of the Nizo 6080 to a quartz oscillator to produce a precise 24 frames-per-second running speed, allowing cableless sync-sound filmmaking with any sound recorder using the crystal sync system (Nagra, Stellavox, Super8 Sound, etc.)

At the heart of crystal sync are independent quartz oscillators tuned to produce a pure and unvarying signal. This extremely accurate signal is the sync reference for both the camera motor control and the recorder. Because of the accuracy of crystal oscillators, there is no need for any sync connection between the camera and recorder.

For filmmakers shooting Super-8, crystal sync literally cuts the umbilical cord tying the camera person to the soundperson—making it possible to shoot Super-8 using the same filming and recording techniques previously only possible in the larger film formats. Since any camera governed by a crystal motor control will be precisely in sync with any other, it is possible to cover an event with multiple cameras, and even with multiple formats. The creative potential of crystal-sync Super-8 is tremendous, as was demonstrated recently by the production of

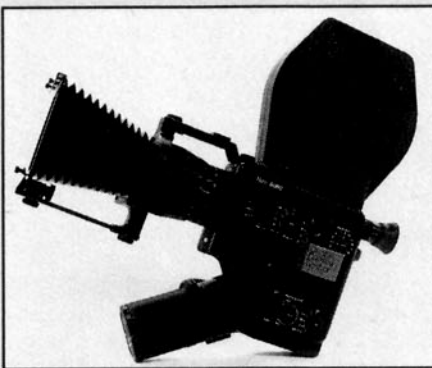

an Aerosmith rock video using Super-8 and 35mm film by Jerry Kramer & Associates of Hollywood.

The Nizo 6080 Crystal Camera Control is 1" x 1 1/2" x 1" and weighs 1 1/2 ounces. It attaches directly onto the camera which serves as its power source. A light-emitting diode indicates proper sync operation. A modification to the camera is necessary for it to accept the crystal control.

The Nizo 6080 Crystal Camera Control is available from Super8 Sound of Cambridge, MA 02140 for \$250. Modification of the 6080 to accept the crystal control is also available from Super8 Sound for \$95.

New 16mm Film

Eastman Kodak Company has introduced a 16mm high-speed color negative film with noticeably improved imaging characteristics. Eastman color high speed negative film 7292 features readily apparent improvements in image sharpness and grain structure. The new emulsion, which will replace Eastman color high-speed negative film 7294, has a recommended exposure index of 320 in 3200 K tungsten light and 200 in daylight with an 85 wratten gelatin filter.

This new 16mm film is specifically designed to provide producers with the wide latitude that they often require to work in natural or low-light conditions without sacrificing image quality. It is an excellent companion for the popular medium-speed Eastman color negative film 7291.

Filmmakers will be able to intercut the medium and high-speed emulsions without noticeable differences in color, sharpness, or grain.

The improvements in the image structure of the 7292 film are most noticeable by the reduction of grain in shadow areas, especially when the film is exposed in low-light conditions. The use of this advanced emulsion technology in the two green-sensitive layers, which normally provide the biggest contribution to screen graininess, enables us to significantly reduce granularity in the toe area. Using this technology in the "slow" blue-sensitive layer affords granularity improvements in the mid-scale to shoulder of the blue-sensitive layer. The overall effect of these changes is readily apparent in the final displayed image whether it is an optically projected print or a telecine transfer.

The improvements in the grain structure of the new, high speed color film are most evident in the "toe" of the green-layer sensitometric curve, which relates to the shadow areas of the picture. There are also some gains made in the mid-scale to "shoulder," or the mid-to-brightest part of the image are in the blue-sensitive layer. Improvements in image structure such as these can sometimes be compromised as film speed increases. However, Eastman Kodak's contacts with 16mm users indicate that speed is not as important a factor as image quality for this film format. The granularity improvements in the toe region will be seen as image quality improvements in shadow areas of the picture when 7292 film is exposed at EI's higher than 320.

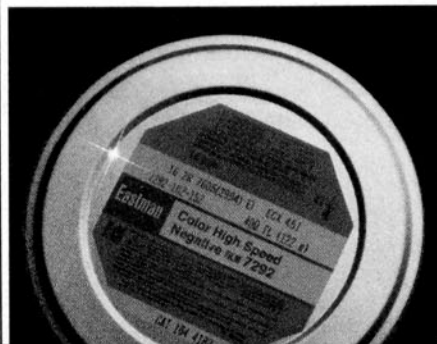

Minolta HQ Video

Minolta Corporation has introduced the CR-1100S AF—a new, video camera-recorder featuring the new "HQ" high quality circuitry for improved picture quality. The new Minolta CR-1100S AF is an all-in-one unit that accepts full-size VHS cassettes. The camcorder features infrared autofocus and auto exposure, and a large electronic viewfinder that doubles as an instant replay monitor.

The HQ system provides better video pictures in four ways: white-clip level expansion, to sharpen the edges of objects in a picture; detail enhancement, to improve overall picture sharpness; luminance noise reduction, to cut down on "snowy" pictures; and chrominance noise reduction to reduce "snow" in the picture's color signal.

The shooting controls on the new Minolta CR-1100S AF are positioned for fingertip operation so that users rarely have to look away from the viewfinder to make adjustments. Its design makes the Minolta CR-1100S AF a lightweight and comfortably-balanced unit.

The 1/2-inch, 4.3 MHz High-band Saticon picture tube in the CR-1100S AF provides superb video quality, even when shooting dimly lit scenes, as low as seven lux.

The camera-recorder's 2/3-inch viewfinder has a visual signal that indicates when recording is in progress. The playback feature lets videographers instantly view the scenes they have just recorded.

The Minolta CR-1100S AF also has a manual iris control. Users can use this feature to improve backlight shots and make adjustments to create fade-ins and fade-outs.

The Minolta CR-1100S AF also features a special recording drum around which the tape instantly wraps when the videocassette is inserted into the camera-recorder. This makes the CR-1100S AF ready to record on demand. Additional features include a unidirectional microphone, and input jack for connection to a standard TV or another VCR, an earphone jack, a remote pause control jack, a tracking control dial to ensure optimum video performance.

The Minolta CR-1100S AF is powered by a one-hour battery, which is included. A battery-level indicator shows when the battery needs recharging.

Suggested retail price for the Minolta CR-1100S AF is \$1,833.00.



Video Cart

The model GR-3 Wheelit Folding Video Cart is designed to store, transport, and operate any portable 1/2-inch VCR system. It can hold up to 150 pounds of equipment plus up to a 10-pound camera on its mono-pod column with fluid head that smoothly pans or tilts to get that perfect "shot."

The mono-pod elevates from 3'7" to 6'10" to get those important over-the-head shots when everyone is standing in front of you. Three brackets and equipment straps are provided to securely mount all equipment to the cart so there is no danger of something coming loose and falling during a hectic "shoot."

A big 34-by-13-inch component board will hold any size equipment and 4-inch swivel casters with locks plus 8-inch semi-pneumatic tires and steel frame provide cushioning and strength to protect delicate electronic equipment. When not in use, the Model GR-3 folds to a slim 8-inch width to fit into any trunk, hatch back or closet easily. Retail price is \$340, shipping prepaid and is available from Wheelit, Inc., 440 Arco Drive, Toledo, OH 43607.

Car Bracket

Whenever it is impractical to use a tripod, the Gitzo Cambrac attachment may be your answer to support cameras, projectors, microphones, electronic flash, floodlights, telescopes, other instruments up to 20 lbs., in motorcars or boats, on fences, shelves, doorstops, chairs, tables, ladders, etc., and with a stirrup bracket, even on a tripod. The solid 10" x 3" support bracket with movable 1/4" camera screw has a 6" wide, 1 1/4" deep overlap for hook-ups, wherever possible. It is braced with a hinged second bracket with a bracing arm for angles from 0 to 100 degrees. Any pan-tilt or ball-and-socket head can be mounted between Cambrac and camera for additional tilts and pans. A special Cambrac leaflet illustrates just 17 examples, but there are multiple other applications for camera positions, which would otherwise be impossible. As with all Gitzo tripods, monopods, heads and accessories, it is covered by the Full Gitzo Warranty Buyer Protection for life. Price \$119.95.

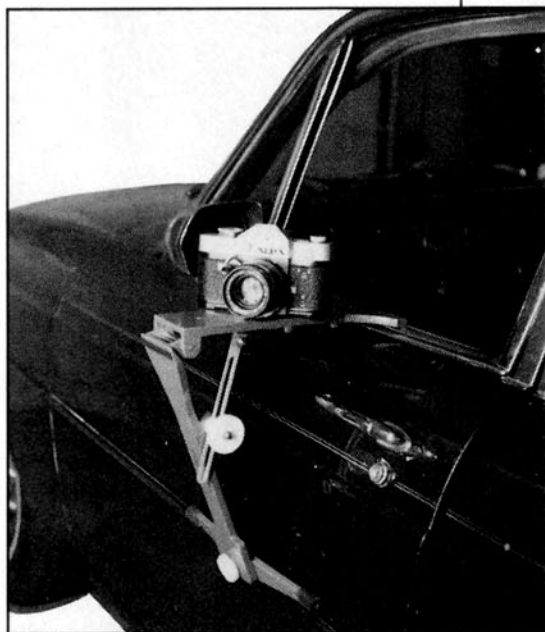

VHS Camcorder

A lightweight battery powered portable camcorder, that combines a VHS video cassette recorder and color video camera in one unit, is now available from RCA at authorized dealers nationwide. The new RCA "ProWonder" camcorder uses standard VHS video cassettes and retails for under \$1500.

In one self-contained unit, consumers can now enjoy the full benefits of a portable video cassette recorder and a color video camera—without the hassles of lugging around extra weight, power cords and cables. Weighing a mere 5.5 pounds, the RCA ProWonder makes home video movie making simple. All the consumer has to do is insert a standard VHS video cassette, make sure the camera's autofocus and low light modes are on, and shoot.

The camcorder features an f/1.2 lens with 6:1 power zoom, a built-in infrared auto focusing system, automatic iris, and a constant automatic white balance that automat-

ically adjusts for proper color balance indoors or out. The new system incorporates a half-inch Saticon pick-up tube that delivers an extremely sharp picture even at light levels that are as low as 7 lux, making it equally ideal for use indoors and outdoors. Its 2/3-inch electronic viewfinder doubles as a monochrome monitor for viewing "instant replays" immediately after taping. The RCA ProWonder also features a built-in microphone and an adjustable diopter that allows the electronic viewfinder's focus to be changed, permitting users who wear eyeglasses to remove them when operating the camera.

Included with the purchase price of the RCA camcorder unit is a detachable carrying handle, shoulder strap, audio-video cable for playback on a monitor TV, earphone, AC adapter/battery charger and a one-hour rechargeable battery. Because the AC adapter/battery charger operates on 110 or 220 volts, 50 or 60 Hz, the unit can be used in many foreign countries.



GRIP KIT

Beaulieu 7008S

The introduction of the new Beaulieu 7008 firmly establishes Super-8 as a professional production format. Similar in design to 16mm cameras, with such features as a mirror shutter, ground-glass focusing, interchangeable C-mount lens, and a crystal sync camera control, the new Beaulieu 7008 further advances the professional production capability of the Super-8 format.

Beaulieu has engineered into the new 7008 a digital frame counter for the precise placement of multiple exposure effects—a feature unparalleled in any format.

The new Beaulieu 7008 comes with an f/1.4, 6—90mm Angenieux lens, with multi-coating for excellent color rendition, and a unique macro focusing down to two feet at any focal point in the lens's normal range (6mm to 90mm).

The 7008S features a variable speed motorized zoom that will travel the 15:1 range in from 4 to 10 seconds, and a quick zoom button for dramatic zoom effects.

Finally, the wide range of focal lengths in the Angenieux's 15:1 zoom ratio—the greatest of any Super-8 camera—all but eliminates the need for interchangeable fixed focal length prime lenses.

For filmmakers who require still greater telephoto or wide-angle capability, the new 7008S features an interchangeable C-mount

that offers the option of using a full complement of fixed focal point prime lens.

The Beaulieu 7008's C-mount also makes it ideal for scientific research. It can be mounted on microscopes, telescopes, or anywhere a 35mm SLR camera can be mounted for research applications.

The new 7008's digital frame counter counts frames, forward and backwards, from 0000 to 9999, i.e. over a period of seven minutes at 24 fps. Such precise backwinding control enables you to do a number of lab effects in camera.

The 7008's backwinding capability and digital frame counter also gives you the control required to create matte effects such as split screen images.

When doing such special effects, a 50-foot cartridge allows you to backwind the film for a full 10 seconds of double exposure. But to give you even greater creative control the 7008S accepts the 200-foot cartridge which allows you to backwind over the entire length of the twelve-minute cartridge.

Designed more like a 16mm camera than a Super-8 camera, the new Beaulieu 7008 employs a mirror shutter. It enables you to see through the viewfinder the effect of the selected aperture on the depth of field in a particular scene.

The 7008S features Beaulieu's patented "Hall Senser System"—an electronic device which keeps a perfect loop between the

picture gate and the sound head. This innovation keeps "wow" down to an incredible and inaudible 0.3 percent. The frequency response is from 50 to 12,000 Hz at 24 fps with a signal-to-noise ratio of 60 dB. The quality of sound is then better than that of the average tape recorder or projector.

A flash/sync contact enables you to record double-system sound in lieu of, or along with, the built-in sound system. Double-system filmmaking is accomplished by using two pieces of equipment—a camera and a Super8 Sound Magnetic Fullcoat Recorder. In this sync set-up, called "cable sync", a cable connects the camera's flash/sync output to the sync input of the Super8 Sound Recorder, and the recorder maintains sync against the sync reference pulse generated by the camera's flash/sync contact.

Finally, the 7008S enables you to control the speed of action by shooting at 4, 9, 18, 24, 36, or 56 fps (although sound film can only be shot at 18 or 24 fps). It will accept the Kodak 200-foot sound cartridge for twelve minutes of uninterrupted shooting. The 7008S also features single-frame capability and a built-in intervalometer that will expose 1 frame per second, 1 frame per 10 seconds, or 1 frame per 30 seconds. The 7008 will run on rechargeable nicad batteries or alkaline batteries, and can be remotely powered by a 9-volt battery pack.

Hokushin X-600

The new Hokushin Model X-600 16mm Xenon projector is so automatic, it is virtually like having a robot at the operator's command.

Introduced in the United States by Rangertone Research Inc., the X-600 offers optional wired or wireless remote control for every function—including opening the film gate, starting projection, and rapid rewinding without rethreading.

Even without remote control, these functions are highly automated through the use of soft-touch switches and micromotors designed into the X-600.

Ideal for theatrical, industrial, and educational purposes, the lightweight, compact X-600 offers optical and magnetic sound reproduction, a powerful 75-watt audio amplifier, and 600-ohm line output. Film is conveniently threaded along rollers in the X-600's slot-loading design.

Besides wired or wireless remote control, a host of other useful options is offered from a electronic auto-repeat adapter to automatic changeover control, and a long-play (6,000-ft. capacity) reel unit.

For further information on the Hokushin Model X-600 16mm Xenon projector, contact Rangertone Research, Inc., 115 Roosevelt Avenue, Belleville, New Jersey 07109. Phone: 201-751-6833 in New Jersey, or toll free in other states, 1-800-221-1823.



Carter Cartop Platform

Anyone who has a need for a sturdy camera platform on top of a car or van will find the quality made Carter Cartop Platform just what the doctor ordered.

A substantial access ladder is also included. To find out more write to Harry Carter Cartop Mfg. Co., P.O. Box 184, Welches, OR 97067. Models from \$995 to \$1955 (5' to 12' for vans).

Video System

The Panasonic 3500 Production System, comprised of a WV-3500 color video camera and a WJ-3500 special effects generator, has been designed for use in both the studio and as an electronic field production (EFP) system. The WV-3500 camera offers high performance with a high-band 2/3-inch Saticon tube, which provides 350 lines of horizontal resolution and requires a minimum illumination of 3 footcandles at f/2. Accepting power from a variety of sources, including portable VCRs as well as the WJ-3500 special effects generator, the WV-3500 includes a 1.5-inch viewfinder with digital indicators, internal and external sync, external mic jack, audio monitoring facilities, auto white balance, indoor/outdoor filtering, auto gain control, built-in unidirectional microphone and a negative/positive reversal switch for use with telecine equipment.

A professional 12:1 power zoom is included with the WV-3500. The wide focal range of 10mm to 120mm enables the user to capture action far in the distance or on a blade of grass with the macro function. The f/2 lens is equipped with power zoom operation and automatic iris adjustment control. The interchangeable bayonet mount lens accepts standard 72mm filters for special effects and precise image control.

The WV-3500 incorporates a genlock input (BNC), which will accept composite video (VBS) as a reference signal. When connected to the WJ-3500 special effects generator, the genlock signal is received through the camera's 10-pin connector cable. When connected to conventional SEGs, the genlock is received through a separate BNC connector on the camera body.

When using the WV-3500 with the WJ-3500 special effects generator or other SEGs, the sub-carrier and horizontal phase controls on the camera can be adjusted to provide matching with other cameras within the system. These controls are easily accessible on the camera. Horizontal and vertical blanking widths are switch selectable.

The fade-out mode on the camera automatically activates the stop mode on the host

VCR when the signal goes to black.

When used with the optional WV-AD15 negative/positive film adaptor, the WV-3500 camera can convert positive or negative pictures into positive video images for instantaneous film transfer recording. The reversal switch on the camera can also be used independently to create special effects when recording normal video.

The WV-3500 also provides the capability to fade in and out both the audio and video signals.

The WJ-3500 special effects generator offers a wide range of capabilities. It can wipe or fade between cameras one and two as well as between camera two and line video inputs. Both horizontal and vertical wipes and split-screen shots are easily accomplished. The switching features of the WJ-3500 can greatly enhance video production quality.

The standard accessory titling camera that is integrated with the WJ-3500 allows for the superimposition of a variety of titles into video images. Seven colors can be keyed in on seven color backgrounds. It is also possible to add graphics for additional effects.

The WJ-3500 incorporates an advanced digital sync generator with genlock so that you can integrate different video sources when recording final production. Titling and background colors are always available without any external input source. When using a camera without genlock capability or a stable video line input, the sync generator will adjust the system to use this input as a reference signal. Thus, there is no need to worry about using existing cameras without genlock capability. However, for cameras with genlock capability, a black burst output is available on the WJ-3500. This black burst output can also drive time base correctors for synchronizing VCRs.

The WJ-3500 also allows mixing of audio signals from camera one and two, or from the line input and a microphone input. You can also mix or add signals from a line input with that of camera one or two.

Designed to cost no more than a few rentals of special effects and post-production equipment, the 3500 Production System has a suggested retail price of only \$2,900.00; \$1,750.00 for the WV-3500 camera and \$1,150 for the WJ-3500 system switcher.

Fax Mini Stand

The Fax Company, a supplier of animation equipment and supplies, is marketing a Mini-Studio Camera Stand for video and 16mm cameras that is affordable for many independent filmmakers. The Fax Mini Stand comes complete with a 12-field disc (two moving top and bottom bars), platen, studio lamp bar assembly with brackets, camera pedestal to wall braces (bolts and screws included), and leg assembly. The Fax Mini Stand is suitable for 16mm and video animation. The disc does not rotate. The price is \$1,074.00. Fax also sells many types of animation supplies and much more sophisticated (and expensive) equipment. Among the other equipment and supplies Fax sells are: animation discs and tables, ink and paint boards, peg bars, cel punches, TV storyboard pads, acetate cels, TV cut-off charts, field guides and books about animation. There is a \$25.00 minimum on all orders. Write for their catalog, Fax Company, 1430 Cahuenga Blvd., Hollywood, CA 90078.

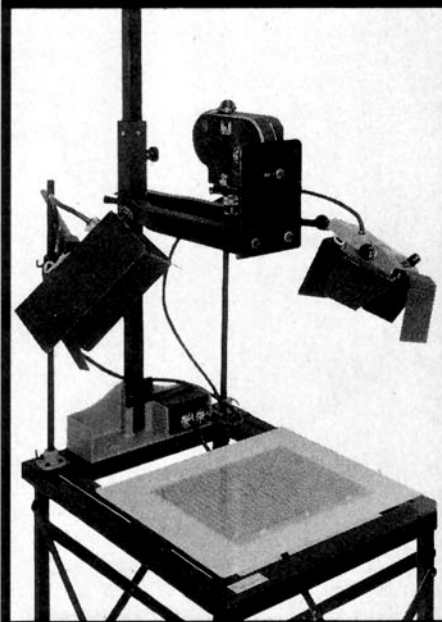

New Kodak 5243/7243

The improved Eastman color intermediate film 5243/7243 features enhancements in speed, grain and image sharpness, says Leonard F. Coleman, general manager and vice-president of marketing for Kodak's Motion Picture and Audiovisual Products Division.

Coleman explains that several layers of the color intermediate film have been modified, in part, by employing technological advances made in T-Grain emulsion. This has resulted in an increase in the speed of the blue-light-sensitive layer of the emulsion of almost a full stop, and improvements in sharpness and grain.

The faster speed in the blue-light-sensitive layer of the improved intermediate

film will give optical printer operators somewhat more flexibility in exposure control. It will also allow them to operate printers faster. "This could allow optical houses to handle some jobs a little faster, and it could, therefore, permit them to handle more work," Coleman notes.

Coleman believes that enhanced image sharpness and grain characteristics are an even more significant development. He points out that it is a common practice for an intermediate film to be used at both interpositive and internegative duping stages before prints or video transfers are made.

"The improved imaging characteristics inherent in the new color intermediate film are compounded through each generation," he explains. "There should be a general improvement in both video tape transfers and

film prints made from intermediates, especially prints made for overseas release, since these are usually one generation further removed from the original."

Coleman says that the improvements in the color intermediate film will produce results which very closely rival color reversal intermediate film, a one-step alternative for making color release prints.

The new intermediate film is scheduled to replace the current emulsion by early 1986. "We anticipate a smooth transition since there are no changes in processes or handling," he says. "Even the name of the color intermediate film will remain the same. However, our engineering staff will be working very closely with labs using the new intermediate film to make sure that everything goes smoothly."

CM

Making Monsters

By THOMAS VIALL

For a while in Hollywood, it seemed that any self-respecting monster had to be larger than life—King Kong in the early 30s, Godzilla in the 50s. Even most aliens were life size or bigger. Gort the robot stood at seven plus feet, as did Ridley Scott's *ALIEN*. But, here we are in the 1980s. Everything from cassette players to computers are getting smaller and smaller; things that go bump in the night are following suit. From E.T. to the Gremlins, creepy things are shrinking faster than Grant Williams. For the low budget filmmaker this can be both a curse and a blessing.

Since the invention of 8mm, the disciples of Roger Corman have had friends in makeup and masks, costumes and cosmetics to star as the main distractions in their space operas or fright flicks. But, for the filmmakers who want to stay up on big budget technology, it is time to make a miniature monster. It is time to chuck that rubber mask and start thinking small. While Carlo Rambaldi spent \$700,000 to bring E.T. to life, the budget conscious director can create an alien for far, far less. All it takes is a little imagination, a lot of inventiveness, and a few dollars.

First, it is important to decide on the approximate size of your creature. Along with this decision you must determine how your creature will be operated—this is where the inventiveness comes in. For my film *Crashsite*, I decided that the pilot of a wrecked spacecraft should be about four feet tall and look like a cross between an alligator and a BEM—(Bug-Eyed Monster). The only visible parts of the creature would be the head, operated much like a puppet, and one claw, again operated by hand. The rest of the creature, including the kneeling operator, would be covered by a robe.

The head is the place to start. To get a rough idea of what the finished creature will look like, model a small head out of Plasticine. This way you can get a good

Plastic milk bottles and other plastic household items make a great foundation for the monster's skull. A styrofoam ball cut in half works well for bulging eyes.

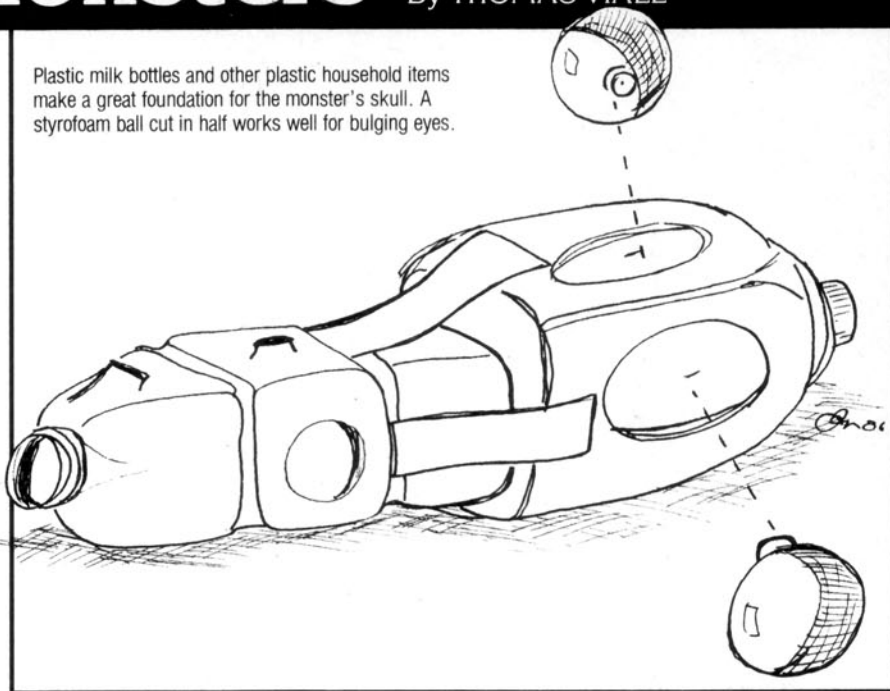

idea of how the monster would look from all angles. The next step is to forage around the house for shapes to make the skull. Plastic milk bottles, shampoo bottles, small plastic planting pots, and straws make a great foundation. For the eyes that make a BEM a BEM, I used a styrofoam ball cut in half and glued onto both sides of the skull. Shape, rather than appearance, is the important part of this step. Use sharp scissors, a modeling knife, and plastic tape to build the form. Neatness here does not count; just tape the shapes together in the way that works best. When you are satisfied that the conglomeration of odds-and-ends is the approximate shape of your plasticine head, cut an access hole in the base for you hand to fit through.

The next step is to purchase a bottle of liquid latex rubber. A good art supply house or theatrical makeup company should carry this item. A 10-ounce bottle should be enough for the job. With a small paint brush, coat areas of the head with the latex. Then, while the latex is still wet, lay pieces of tissue paper over the area. Using your fingers, press the paper down so it absorbs the latex.

You will find that with a little practice you can mold wrinkles into the paper by pinching the paper between your fingers. Large veins can be made by rolling the tissue into small tubes, dipping them directly into the latex, and then applying them to your form.

Your monster can be made to show only the head and one arm and can be designed to be operated as shown in this illustration. Don't hide the rest of the monster behind objects, just crop it out of the frame.

Pieces of vinyl can be used to cover large, smooth areas by taping the vinyl down along the edges and latexing over the sides. Because this is the skin of your creature, it is important to work a lot of texture into this part of your creation. Also, be sure to work in a ventilated area. The latex has an ammonia base and the fumes are unpleasant. When the latex is dry, fumes will not be a problem.

I decided to give my creature a long neck. To accomplish this, I used vinyl scraps to make a cylinder big enough for my fist to fit through. Because sewing is not one of my strong points, I simply stapled the sheets together. Then, armed with my latex and tissues, I attached the cylinder around the hand hole in the skull and "skinned it up" to match the texture of the skull.

Adding scales is a snap by using thin styrofoam sheets. Start hoarding trays meat comes in from the grocer, egg containers, and the like. Using the biggest sheets possible, cut the sheet into strips about an inch wide. Next, cut a series of short, round waves out of the styrofoam. Glue, or tape the strips down in layers so that the rounded edges overlap the straight ones. Once again latex over the strips. Working this way you can build up a very scaly creature indeed.

In many ways hair is easier to add to your creation than scales. First, buy an old wig from a resale shop, or a Salvation Army thrift store. Cut tufts of hair of varying lengths from the wig. Wet an area of your monster with the latex and then lay one end of the hair over the wet area. Then gently brush the non-sticking hair away from the monster. Working in small areas

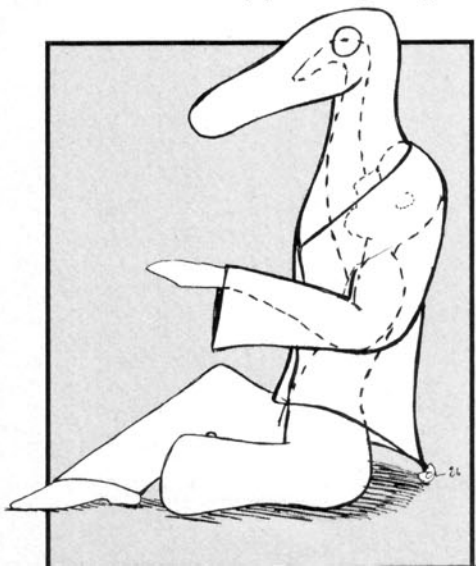

One way to make an alien hand is to build one up from a rubber glove. You can bind the fingers together for a three-fingered hand. Cover with tissue and latex.

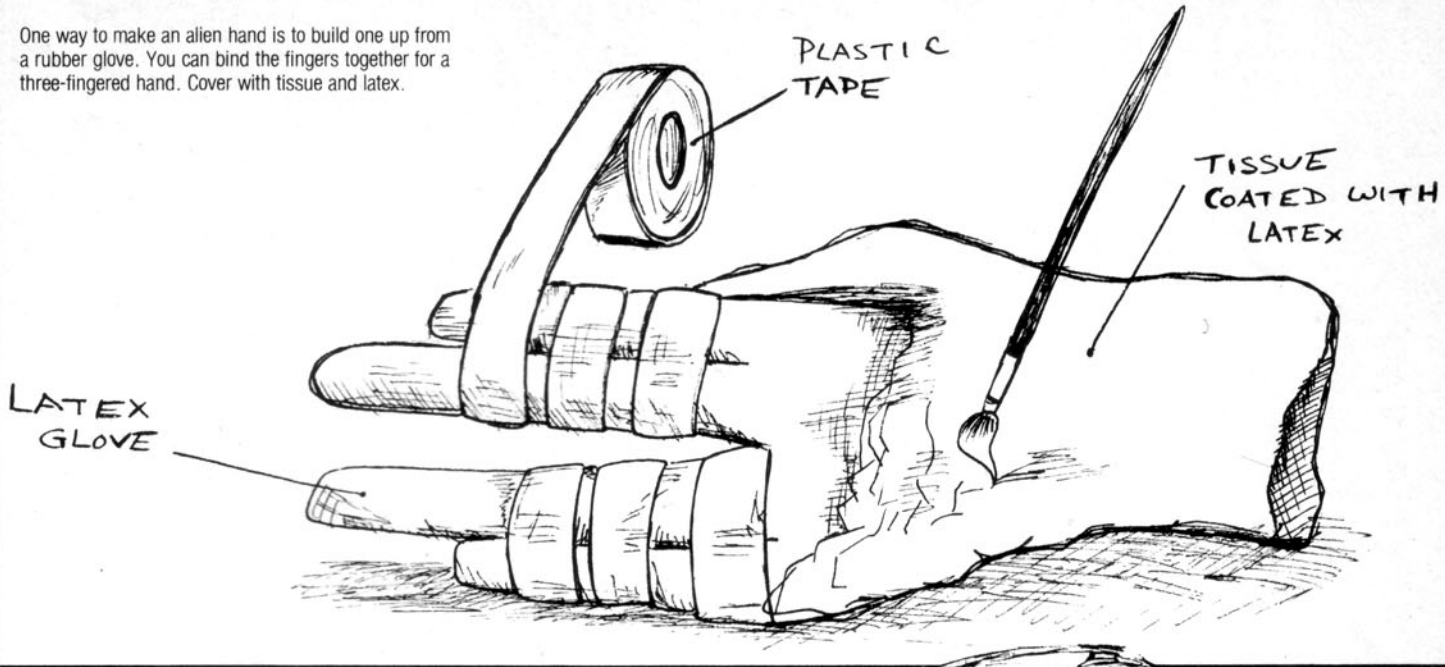

it is possible, with time, to make a very hairy creature.

By this time your creation should begin looking very alien. It will have an awful yellow-white skin and wouldn't fool any one. It is time to paint. Unless you've done so already, it is also time to jerry-rig something to hold your creature's head up while working. I simply slipped mine over an old tripod to hold it steady during painting.

Using spray paint, give the head and neck a base color, usually a dark brown or green.

Use black to give the base color some texture by holding the can away from the head and hitting it with short blasts from the can. For my alien I used a base color of flat black and then held a can of orange in one hand, and a can of gold in the other to blend together a very alien skin tone.

Avoid painting the eyes white, with pupils. Instead, make them a solid color, slightly darker or lighter than the rest of the head. Eyes are the hardest things to recreate realistically—a bad paint job here will rob your creation of all credibility.

Last, but not least, you may want to coat the head with clear enamel spray paint. This will add a gloss to the skin color that will make it seem moist, often a desired effect.

For the experienced head builder, a hand or a foot is not trouble at all. For an alien hand, buy a pair of latex household gloves at the grocery store. Then, using the liquid latex and tissue go to work. You may want to bind the fingers together into a permanent Vulcan salute for a three-



Your finished monster may look something like this. Creative lighting and editing can help make your creature convincing on screen.

fingering monster, or build up the length of each finger into a Nosferatu-like claw. Paint the hand the same color as your alien head.

To make feet, I suggest constructing them in the same manner as the head. First determine shape, then create a form, and lastly go to work with your latex and paint. After they are completed, attach short dowels to the top of each alien foot. Chances are you will not be showing them too much. It is rare that any film spends too much time on feet of any kind. Remember to keep the color of your alien appendages consistent with the head. If the monster has a hairy cranium, give him hairy knuckles as well.

Shooting is where you really bring your pint-sized creature to life. Remember that it is best never to show your whole creature at once. Show the head in one shot and the hand in the next. If this is done correctly, your creature may not need to have a formed body. The more left to the imagination the better. Cut fast—remember, a good effect is never dwelt on. Show it fast and leave the viewer wanting more.

The most important aspect of getting your creature on film is movement. Practice moving your wrist and arm to give your creature subtle, fluid motions. Keep eye contact with all other characters and develop a personality for your creation. I named my creature Bernard and tried to think of him and his operator as one character. It will help you as a director to first shoot a test reel of the creature to determine proper lighting and different movements. The darker the lighting the better. Back lighting works best.

You may decide you want a shot showing the whole body of your creature. If this is the case, I suggest outfitting the operator in loose robes, or a satin sheet. Have him or her kneel, or even lie down while keeping the head of your monster held high. If you choose your camera angle carefully, you should be able to keep the operator hidden. Avoid sticking the operator behind obvious objects, such as bushes or furniture. It is better to film just the head rather than having the head sticking up from behind a hiding place. Remember, most puppeteers work on a stage, where viewers can look anywhere

they want. Because of this, they have to remain hidden behind a wall or curtains. But, as a filmmaker, you can force the viewer to see just what you want, how much you want, and for as long as you want.

Most of all, watch how the big budget guys do it. Pay careful attention to Yoda's movements—or even Yoda's distant cousin Grover on *Sesame Street*. See how a good puppeteer like Frank Oz can bring a sock and two ping pong balls alive with good movements. You can get as fancy as you want building your own monster. You may wish to use string to open and close the mouth, or try almost anything else. Bernard had a tube that ran from his mouth to the operator's mouth, so that on a cold night the creature would have realistic breath steam. While any innovation is possible, my advice is to keep your goals realistic. You will be surprised to see how much you can get out of a basically stolid creature. If you work hard, you will receive one of the best compliments any director can hope for—a viewer asking, "Gee, how did you do that?"

CM

CineMagic

MARKETPLACE

For as little as \$15.00 you can reach all our special effects fans.

DEADLINE: CINEMAGIC #34 in our office by July 30.
CINEMAGIC #35 in our office by September 4.
BASIC RATE: \$5.00 per line. Limit—45 characters per line. Minimum three lines. Punctuation, symbols and spaces count as characters. Small Display ads—\$40.00 per column inch (camera-ready ONLY!!)
HEADLINE: First line only—Word(s) of your choice (underline them) will be printed in **BOLD CAPS**.

CATEGORY: PLEASE BE SURE TO INDICATE THE CATEGORY YOU WANT TO BE LISTED UNDER.

PAYMENT: Cash, check or money order must accompany ad order. (checks payable to Starlog Press, Inc.)

MAIL TO: CINEMAGIC, c/o Starlog Press, Inc.
215 Park Avenue South
New York, NY 10003.

MOVIE POSTERS

Original Movie Posters!
Fast Personal Service
Catalog \$2.00 (Refundable)
POSTER GALLERY, BOX 2745
DEPT.#3, ANN ARBOR, MI 48106

CATALOGS

ANIMATION MODELS, films, how-to books, and other EFX memorabilia for sale. Send \$1.00 for current catalog. Wallace Jones Studios, 5312 Manson Rd., Julian, NC 27283.

MAKEUP FX ARTIFICIAL EYES—Hand painted eyes custom made to order in any size or color. Also specialized items and lab services for the effects artist or maskmaker. Send 50¢ and a long SASE for catalog and price list to MILLENNIUM STUDIO, P.O. BOX 19932, Birmingham, AL 35219.

EFFECTS—Magazines, Books, Films, Front Screen, Animation Supplies, Latex, Flash-Smoke Devices, Miniature Supplies. Catalog \$2.00—EFFECTS UNLIMITED, P.O. Box 2246, Rockville MD 20852, Dept. CM-1.

HARRYHAUSEN & OTHER STOP-MOTION MEMORABILIA. Selling 15 year collection. List #1 out now. Send \$2 bill to Allan Osborne, 435 Bay Street, Port Melbourne, 3207. Victoria, Australia.

NIGHTMARE FACTORY

DISCOUNT PRICES!
WORLD'S LARGEST SELECTION OF QUALITY MASKS, MAKE-UP, & ACCESSORIES.

Latex appliances, special effects items, movie and haunted house props, 3-D T-shirts, rare collectibles, and much more!

Catalogs—\$3.00 (Refundable)
V/MC/AE

7134 No. Mesa, El Paso, TX 78812
Tel. 915-833-0600

MERCHANDISE

SHAPE UP! Wear this mask and everyone will be talking about the night YOU came home! The "White Shadow" is only \$39.95. NIGHTMARE FACTORY, 7001 Granero Dr., El Paso, TX 79912.

SOUNDTRAK MUSIC! New cassette composed just for filmmakers! One full hour of music to choose from! Dolby Stereo! Only \$8.95 + \$1 post! Custom scores done too! Also, Space Projection Slides Vol. 1—\$7.95! Scott Weaver Prod., Sooy Lane, Absecon, NJ 08201 or write for info.

AT LAST! A MASK & FACIAL APPLIANCE KIT. Everything you need to make your own custom latex masks and prosthetics. Kit includes plaster, clay, latex, paints, hair, tools, complete instructions and more. Only \$44.95 NIGHTMARE FACTORY, 7001 Granero Dr., El Paso, TX 79912.

FREE OFFER!
MOVIE SCRIPTS!
★ GIANT CATALOG ★
NOW AVAILABLE! Scripts from your favorite Sci-Fi & Horror Movies. From Frankenstein to Ghostbusters! Over 3000 amazing titles!!! Send 50¢ (refundable) for a huge catalog... Receive FREE offer!!! Send to: SCRIPT CITY, 1765 N. Highland, #760SL, Hollywood, CA 90028

SERVICES

SEMI-DERANGED COMPOSER is capable of creating Unique Origine' Music for Horror/Sci-fi films. Joseph Proglor, Box 29., Mahopac Falls, NY 10542.

START YOUR OWN MASK BUSINESS! Everything you need to know; diagrams, formulas, suppliers, sculpture tips, distributors' addresses, etc. Send a SASE to David Ayres Special Effects Studio, 204 N. Fraser Dr., E., Mesa, AZ 85203.

Magnetic Sound Striping. Finest magnetic striping. Weberling lamination Super-8/8 mm 6¢ per ft, 8¢ per ft. with balance stripe. Rush Service. MAGNETSTRIP, 333 Aycrigg Ave., Passaic, NJ 07055. (201) 773-4633.

PRINT YOUR FILM or video club's ID on letters or stamp your own ID labels for your film cans, video cassettes, film & video equip., or stamp your ID on back of your photos with your own three-line return address rubber stamp. Send only \$4.50 plus 35¢ postage per stamp to STAMP CRAFT, P.O. Box 389, Burgettstown, PA 15021. Add 75¢ for each extra line of info required. PA residents add 6% sales tax.

(continued from page 33)

A: Well, now we're ready to combine the actor with the background. To do this, we have to take the original color (blue-screen) image of the actor and isolate him against a black field. At the same time, we have to insert his silhouette onto the color background, so he can be exposed into it.

The first step is to take the *negative* of the silhouette (the *countermatte*, a clear "window" of the actor surrounded by black) and sandwich it with a color print of the blue screen shot. The black area "blocks out" the blue screen; all that shows is the color image of the actor.

Then, as you've probably guessed, the actor's silhouette is sandwiched with a color print of the background. That sandwich is printed onto unexposed color negative, yielding a single strip of the film of the silhouette moving against the scenery.

Since this is our final "dupe negative", we don't have to take it out of the camera section of the optical printer. It's simply wound back to the beginning, and the color image of the actor (now against black) is exposed into his silhouette.

When the color dupe negative is processed and a print of it is made, *Voilà!* Foreground and background are as one.

Q: I think I've finally gotten a handle on the blue screen process. But hey, this is complicated!

A: Oh, sure. I'm not pretending that it's a snap. You can see just how many film strips are needed to marry a foreground and background into a single scene. And believe, me, I've simplified everything in explaining it. Depending on the complexity of the shot, many intermediate steps come into play. That's standard operating procedure in most optical houses.

Q: You mean, not all blue screen composites are done the way you've explained it?

A: The principle is always the same. We need a color print and a color negative of the blue screen shot (the "insert"). We need a blue-filtered version of the insert on black & white positive film. We need a silhouette matte of the insert, and a countermatte. And we need a color print of the background. All this, just to get an actor or an object inserted into a duplication of that background.

Q: So what are those intermediate steps you mentioned?

A: The most important one is the use of *interpositives*. Most optical houses transfer the color print of the blue-screen insert and the color print of the background onto this special interpositive stock.

Q: Just what is "interpositive" stock and what's the reason for it?

A: Well, remember, we're rephotographing color material and transferring it onto a new negative. And anytime you do that, you build up *contrast*. To avoid that, the original color prints are duplicated onto this interpositive stock. It's a positive image, except it's on a *negative film base*.

In other words, it looks just like a print of the insert and a print of the background, except it has an orange tint to it—the same tint that you find on a color negative.

Q: All this, to avoid contrast?

A: Yes. You see, the interpositive stock has a low contrast level. And the interpositive stock is *compatible* with the final duplication negative. That's *the* most important thing. All the mattes and counter-mattes are usually sandwiched with the interpositives of the actor and background during the optical process. The only time the mattes are run with the original color prints is to achieve a *deliberate* increase in contrast. That might happen if the bluescreen shot and the background were slightly washed out to begin with.

There are so many *variations* of the blue screen process. What I've described is one basic approach. The "color difference" system, far too complicated to explain here, breaks the original blue screen shot into red, green, and blue "records" and makes possible the reproduction of any color in the foreground, along with the pouring of liquids and smoke.

Q: Something just occurred to me. What if the actor in front of the blue screen has a blue shirt on? How do you deal with that?

A: Of course, one tries to avoid any blue colors in the actor's clothing. Once they blend with the screen, the background scenery could bleed right through the actor in the final composite. Even so, blue colors *are* reproducible in conventional blue screen setups, as long as they can be *tonally* separated from the blue screen on black and white film. In *The Ten Commandments*, several shots of Yul Brynner wearing a blue helmet were "blue-screened" onto desert backgrounds. And the flying bikers in *E.T.* wore blue jeans.

Q: Why is blue used as a backing?

A: Well, any of the three primary colors can be used behind the actor. There can be "red screen" and "green screen." Each can be filtered out on the optical printer for the production of a silhouette matte. Blue screen is the most acceptable for two reasons: (1) since flesh tones do not contain the color blue, they separate cleanly from the screen, and (2) should a matte line occur, a blue "fringe" causes less eyestrain and generally blends better with backgrounds, particularly if a sky is used. Of course, the goal is not to get a matte line at all.

Q: What causes those nasty matte lines?

A: Lots of things. The "blue fringe" you often see around the actor is an artifact of the blue screen that had been behind him during the original take. Generally speaking, it's visible because the travelling matte shrank during development. The silhouette and the color image of the actor no longer fit precisely. When that happens, the countermatte also diminishes—it cannot completely block out the blue screen. So you get an edge. A blue edge. On the other hand, if the matte and

countermatte "bleed" during development, they are enlarged. They *cut off* the screen and the actor ever so slightly in the final composite. And you get a *black matte line*.

Q: I see what you mean. If a red screen is used behind the actor to make the matte, and the matte shrinks, you would see a horrible red outline around his body.

A: Yup. It wouldn't be so bad, though, if the actor was supposed to be on Mars! But that shrinkage of the matte roll has always been a problem, and still is. Bad registration on the optical printer can also throw the system out of whack. Even the tiniest difference in *sprocket holes* between the various film strips can cause the actor to "weave" in relation to the background.

Blue screen work *can* be perfect. The film *Hawaii* had superb shots of people matted onto ocean backgrounds. The blue screen work done by Albert Whitlock and Bill Taylor for *The Hindenburg* was first class. And the pastry sequence in *Young Sherlock Holmes*, where food characters come to life and swarm around the actor, was flawless.

Q: What's the secret?

A: It's just a matter of lighting the original blue screen shot properly—avoiding blue reflections on the actor—and having the time to make the necessary adjustments before the elements are printed together. If the silhouette of the actor shrank, it would be a matter of enlarging it to tolerances of 1/10,000 of an inch. Sometimes it's just trial and error, and having the time and *money* to do those trial runs on the printer. In a mammoth production like *The Ten Commandments*, it wasn't always possible to do this. Time simply ran out.

Controlling the density of the matte is also crucial. If it's *too* dense, it tends to "bleed" around the edges, as I've already pointed out. The result is a big fat matte line. To avoid this, companies like Industrial Light & Magic no longer produce silhouette mattes on high contrast stock. They use panchromatic stock and do some rather neat tricks with it. If the matte is not dense enough, they might take two low-density exposures of the matte and sandwich them together. That way, the silhouette becomes blacker but the *edge* does not bleed. Also, if the actor in a blue screen shot moves rapidly for a second or two, the silhouette of his figure would intentionally be thin and gray, just for those particular frames, to maintain the actor's natural blur. By going a frame at a time on the printer, you can make those adjustments. Of course, none of this is easy.

Q: I'll say! If you keep this up, you'll lose me again.

A: OK. I've said a mouthful. But I'll bet the term "blue screen" no longer shakes you up.

Q: Slowly, but surely, it's sinking in. Thanks a lot.

A: No sweat.

CM

Send cash, check or money order to

STARLOG PRESS®

475 Park Avenue South
New York, NY 10016

DR. WHO COLLECTOR'S EDITION \$16.98
DR. WHO PICTURE DISC \$10.98

DR. WHO SOUND EFFECTS
 Cassette LP \$8.98

GENESIS OF THE DALEKS
 \$8.98

DR. WHO—"THE MUSIC"
 \$8.98

SPACE INVADERS
 \$6.98

BLAKE'S 7
 \$2.30

DR. WHO THEME & THE ASTRONAUTS
 \$2.30

WHO IS THE DOCTOR?
 \$2.30

SCI-FI SOUND EFFECTS
 \$8.98

OUT OF THIS WORLD
 \$8.98

Please include postage and handling

USA \$2.00 for 1st record
\$1.50 for each additional record
CANADA \$2.52 for each record
FOREIGN \$4.52 for each record

NAME _____

STREET _____

CITY _____

STATE _____

ZIP _____

Allow 4 to 6 weeks for delivery.

DR. WHO COLLECTOR'S EDITION

A Two-Record Set

1. "Genesis of the Daleks"
2. "Dr. Who Sound Effects"

Plus:

A 45 rpm Bonus Record!

"Dr. Who Theme"

"Dr. Who & The Astronauts"

A Giant Full-Color Poster!

7 Souvenir Photos!

All for only \$16.98 + postage



WHO IS THE DOCTOR?

(7" 45 rpm)
\$2.30 + postage

DR. WHO—"THE MUSIC"
\$8.98 + postage

DR. WHO PICTURE DISC
\$10.98 + postage



ALSO AVAILABLE!

DR. WHO SOUND EFFECTS
Visit 7 alien worlds!
\$8.98 + postage

GENESIS OF THE DALEKS
Starring Tom Baker!
\$8.98 + postage

BLAKE'S 7
(7" 45 rpm)
\$2.30 + postage

OUT OF THIS WORLD
Atmospheric Sounds & Effects from
the BBC Radiophonic Workshop
\$8.98 + postage

DR. WHO THEME & THE ASTRONAUTS
(7" 45 rpm)
\$2.30 + postage

SPACE INVADERS
Sound Effects from a
Fantasy Space Mission
\$6.98 + postage

SCI-FI SOUND EFFECTS
\$8.98 + postage

DOCTOR WHO RECORDS!

BESTSELLERS

(All records are 12" 33 1/3 rpm unless otherwise noted)

THE KEY TO TIME

A Year-by-Year Record of
DOCTOR WHO

The *Key to Time* marks the program's coming of age—twenty-one years old. Author Peter Haining has adopted the novel technique of exploring the history of the series through key dates in its many life-cycles. He demonstrates—with extensive reference to files kept in the *Doctor Who* Production Office—how the impact of this extraordinary phenomenon has traveled throughout the world. He traces the many changes the series has undergone since the first episode was broadcast in November 1963.

This extensively illustrated special publication, with twenty-four pages of color photographs, is a superb follow-up to the runaway success of W.H. Allen's *Doctor Who: A Celebration*. Hardcover.

Only \$24.95 + postage

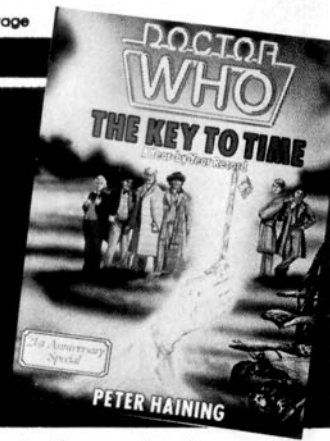

Be the first in your galaxy to own a complete set of paperback novels featuring the incredible adventures of everybody's favorite Time Lord.

DOCTOR WHO Books Please send me the title(s) I have checked below
Starlog Press 475 Park Avenue South, New York, NY 10016

DOCTOR WHO PAPERBACKS - \$2.95 + postage

- 29377 Earthshock
- 20126 Enemy of the World
- 29537 Enlightenment
- 20006 Face of Evil
- 29510 Five Doctors
- 29334 Four to Doomsday
- 20150 Full Circle
- 21279 Giant Robot
- 21543 Green Death
- 20033 Hand of Fear
- 29676 Highlanders
- 20131 Horns of Nimon
- 20009 Horror Fang Rock
- 20866 Ice Warriors
- 20077 Image of Fendahl
- 29617 Inferno
- 20093 Invasion of Time
- 20054 Invisible Enemy
- 20148 Keeper of Traken
- 20125 Keys of Marinus
- 29529 Kinda
- 20147 Leisure Hive
- 20149 Logopolis
- 29393 Mawdryn Undead

- 21455 Abominable Snowmen
- 20108 Androids of Tara
- 29342 Arc Infinity
- 21631 Ark in Space
- 20104 Armageddon Factor
- 21295 Auton Invasion
- 29588 Aztecs
- 21674 Brain of Morbius
- 29860 Brain Teasers
- 21025 Carnival of Monsters
- 29326 Castrovalva
- 21471 Cave Monsters
- 21703 Claws of Axos
- 20123 Creature from Pit
- 21316 Crusaders
- 21498 Curse of Peladon
- 21463 Cybermen
- 21332 Daemons
- 20110 The Daleks
- 21244 Dalek Invasion Earth
- 21965 Deadly Assassin
- 20042 Death to Daleks
- 20096 Destiny of Daleks
- 29553 Dominators

- 20136 Meglos
- 20132 Monster of Peladon
- 21690 Mutants
- 20130 Nightmare of Eden
- 21252 Planet of Daleks
- 21682 Planet of Evil
- 20655 Planet of Spiders
- 20101 Power of Kroil
- 21666 Pyramids of Mars
- 20143 The Quiz Book
- 20092 Ribos Operation
- 20061 Robots of Death
- 21308 Sea Devils
- 29406 Second Quiz Book
- 29457 Snakedance
- 20049 Sontaran Experiment
- 21033 Space War
- 20133 State of Decay
- 20099 Stones of Blood
- 20059 Sunmakers
- 21068 Tenth Planet
- 29385 Terminus
- 21500 Terror for Autons
- 21578 Three Doctors

- 29297 Time-Flight
- 20023 Time Warrior
- 21076 Tomb of Cybermen
- 20068 Underworld
- 20144 Unearthly Child
- 20135 Visitation
- 20082 War Games
- 20146 Warriors' Gate
- 29561 Warriors of Deep
- 21084 Web of Fear
- 21324 Zarbi
- 20138 Dr. Who Crossword Book
- 20139 Dr. Who Programme Guide Volume 1
- 20142 Dr. Who Programme Guide Volume 2

DOCTOR WHO HARDCOVER

- 23351 Doctor Who: A Celebration - Two Decades Through Time and Space \$19.95 + postage
- 23283 The Key to Time \$24.95 + postage

USA
1st paperback—\$1.25
Each additional paperback—\$.75
Each hardcover—\$2.50
FOREIGN
Each paperback—\$1.50
Each hardcover—\$4.50

NEW RELEASES - \$2.95 + postage
29780 Frontios
29940 Planet of Fire
29959 Caves of Androzani
29967 Marco Polo
20155 The Twin Dilemma
20158 Awakening
20166 Mind of Evil

DOCTOR WHO SPECIALS - \$2.95 + postage

- 20063 JUNIOR DR. WHO AND THE BRAIN OF MORBIUS \$2.95
- 20067 THE ADVENTURES OF K9 AND OTHER THINGS \$2.95
- 21615 THE MAKING OF DR. WHO \$2.95
- 20095 DALEK SPECIAL \$2.95
- 21842 THE DOCTOR WHO DINOSAUR BOOK \$2.95

I enclose \$_____ in cash, check or money order.

NAME _____

STREET _____

CITY _____

STATE _____ ZIP _____

Please allow 4 to 6 weeks for delivery

Filmmakers' FORUM

A regular department devoted to readers' comments about filmmaking, their problems and solutions.

Twenty Questions

... I have been reading *CINE-MAGIC* for three years and I am pleased with your articles and projects in them. However, I have come across some problems that need to be solved or looked at.

I have purchased all of your magazines and read every one of them, but I have need of some information on a few of the following subjects: cable controls, travelling matte systems, audio-animatronics, mechanical effects, and rod puppetry.

I would like some information on cable control systems. The books I have read talk a great deal about cables in puppets and space creatures. I'd like to know if you have any books on this subject, and if you can give me the names of the people that use them in their jobs so I can write to them (ex. the people who worked on *Return of the Jedi* and *The Dark Crystal*). I would like to know how the eyes move in the masks of the Skeksis in *The Dark Crystal*.

I would also like some information on travelling mattes (optical printing). Do you have any books that can tell you how to make an optical printer and (not an aerial-image printer).

Next, I need to know how audio-animatronics (automata) works and how to use it in my movies. I have looked into this subject for about a year and can't find any books relating to this subject. I was wondering if you know of any books on this or if you know of anyone in this field I could contact, like George Gibbs who worked for *Temple of Doom* on the burning dummy and the falling dummies in the movie.

I would also like information on mechanical effects like wires and radio-controlled puppets. If you know of any books or people relating to this subject please contact me or give me a list of them.

Finally, I would like some information on rod puppetry and how it is used in films today. I would appreciate it if you could have an article on this subject in your magazine.

Don M. Ascolli, Jr.
1404 E. Dunbar Dr.
Tempe, AZ 85282

Most of your questions concern crafts practiced by a very few people. There is very little published material covering these topics. Do not attempt to build your own

optical printer. JK Engineering (5101 San Leandro St., Oakland CA 94601) sells relatively inexpensive optical printers for Super-8 and 16mm. Rod puppetry has been around for thousands of years and you should be able to find books on the subject in your local library. Sorry, we can't give out names and addresses.

Soundtrack Composer

... 24 year old composer/synthesist wishes to collaborate with experienced filmmakers nationwide. I am especially interested in developing soundtracking for fantasy sci-fi, horror and computer generated films and videos.

Scott Knol
10824 1st. Ave. S.E.
Everett, WA 98204

Cable Outlet

... Attention filmmakers! Are you interested in showing your movies on Creative Outlet (a cable TV show in New Jersey)? If so, please send a self-addressed, stamped envelope to us for a release form and more information.

Independent Filmmakers
Box 2241
Bloomfield, NJ 07003

Blood Bath

... I was recently purchasing Photo-flo solution at a local camera store for use in Dick Smith's blood formula (*CINE-MAGIC* #2), when the salesman informed me that Photo-flo is nothing more than diluted dishwashing detergent. I confirmed this when I asked my photography teacher about it—he makes his own.

I tried using diluted dishwashing detergent instead of Photo-flo in the blood formula, and it not only works—it's cheap! You can make roughly forty times as much Photo-flo for the same price of buying it. What's more, you can more easily adjust the thickness of the blood, as the detergent formula allows for experimentation.

Don't use any colored detergents—they discolor the blood and don't photograph well. I use Ivory, which has good coloration and washes out of clothes easily. Now I make blood by the gallon—not by the ounce!

Russel Richards
1621 Trailridge Rd.
Charlottesville, VA 22903

Super-8 to Video

... As an independent filmmaker who uses Super-8 as a video production format, I feel the press has misconstrued the implications of the video boom for Super-8 film production. Instead of making Super-8 production obsolete, video has opened up new opportunities for Super-8 as a television production format that can rival 16mm and broadcast-quality video tape.

Professionally transferred to one-inch video tape, with electronic color correction and image enhancement, Super-8 offers the video producer that sought after "film" look, with the dynamic contrast range and associated color shifts that have become synonymous with high video production values. This "film" look—as I can personally attest, and as reported in the *SMPTE Journal* and in *American Cinematographer*—is the same whether the original film is 16mm or Super-8. With electronic color correction, it is extremely difficult to distinguish Super-8 from 16mm in off-the-monitor tests.

Today's Super-8 offers the video producer broadcast quality images in a format that utilizes light weight, extremely portable cameras and cassette sync-sound recorders, or single system cameras that combine picture and sound recording in a single unit. Super-8 cameras can go anywhere, operate on penlight or rechargeable batteries and film in extreme low light situations (approximately 10 foot-candles) in full color.

The potential of Super-8 as a video production format is tremendous, as evidenced by the recognition it has recently received from professional media producers—Dan Rather and his CBS crew shot Super-8 in Afghanistan for national broadcasting on CBS News, while Frank Christopher shot his Academy Award runner-up *In the Name of the People* in Super-8.

Guy B. Holt.
95 Harvey St.
Cambridge, MA 02140

... *We couldn't agree with you more, Guy. See Mike Hadley's article, "Film and Tape. The Best of Both Worlds," in this issue.*

Still Looking

... We are dedicated young filmmakers and are looking for

others in the area of Fairfield County Connecticut to join us in the filming arts. If you are very interested in the filming business please write.

Dream Associates
c/o Robert Betts
30 Hunters Ridge Rd.
Shelton, CT 06484

Soundtrack Composer

... Perhaps the most difficult project in completing a film is coming up with an original soundtrack. You could hire John Williams to compose the score. Then again, you probably can't afford it! And no, you don't want to use the *Star Wars* soundtrack, since it's not original. Besides, it would be illegal to use it without permission. How about hiring someone that doesn't cost as much?

In addition to filmmaking, I've been composing music for amateur films. These soundtracks are original compositions mastered in multi-track DBXnr stereo using digital synthesizers, drum machines, effects processors, and sequencers.

If you are interested in a soundtrack for your film, please write to the below address for more information. Demo-tapes are available upon request.

Andrew Petterson
Rt. 8, Box 268
Tucson, AZ 85730

FX Studio Addresses

... I am very interested in obtaining the addresses of various special effect model studios in California. Could you please supply me with these or information as to where I could get these.

Terry Veenstra
154 Main St.
Box 304
Beachville, Ontario, Canada

... *Consult the Los Angeles yellow pages at your local library or telephone company office.*

Rhode Island Filmmaker

... I am 16 years old and would like to get in contact with anyone who is in Rhode Island or the New England area who wants to help in any way in making a horror, fantasy or science-fiction film. If anyone is interested, please contact me at the address below.

Al Caldaroni
65 Pleasant View Ave.
Greenville, RI 02828

Drawing a Blank

... Being an amateur filmmaker, I often use guns in my movies. The only problem is that we have to dub the bullet sound effects in at the studio (my room). I would like to know where I can get some blanks for my guns.

Charles Granberry
F-17 Kemang Indah
Jakarta, Indonesia 12

Almost any gun shop will have blanks in stock.

Long Island Animator

... I would like to either correspond and/or collaborate with other filmmakers in the Greenlawn/Huntington area of Long Island. I'm rapidly becoming an excellent animator of clay figures.

Imaginative Productions
c/o John Kelly
12 Colony Court
Greenlawn, NY 11740

Brazilian FX Artist

... I'm a Brazilian filmmaker and I'm very interested in science fiction, fantasy, animated cartoons, makeup, stop-motion, matte paintings and all kinds of special effects. Here in Brazil we don't have any information about special effects, all I know about the subject is through reading American magazines. I like Douglas Trumbull and other effects artists' work very much. I would like to correspond with anyone who shares my interest in film effects. Please write!

Mario Azevedo Costaneto
Rua Commandante Vergeiro
Da Cruz
No. 580 Penha
Rio De Janeiro, Brazil

Front Projection Supplies

... I have a question that will probably help other filmmakers as well. I have been wanting to use the front projection system in my recent film but I am having a lot of trouble trying to find the Scotchlite 7620 projection material. I would appreciate it if you could possibly give me any addresses of suppliers where I could purchase some.

John Schmitt
6780 Eiler Lane
Cincinnati, OH 45239

Scotchlite front-projection material can be purchased from the Raven Screen Corporation, 124 East 24th St., New York, NY 10035 (212) 534-8408 or from the Front Projection Company, Inc., 49 East 1st St., New York, NY 10013 (212) 673-7290. Some major photographic supply companies also supply front screen material for studio photographers.

Movie Scripts

... I am a reader of your magazine and a sci-fi movie buff. I enjoy watching sci-fi movies not only for sheer pleasure, but also for improving my knowledge of English. I really regret the fact that, because English is not my mother tongue, I can not understand everything the characters in a movie say. A solution to this problem could be to come by the scripts of the movies. Do you think it is possible for me to acquire them? If it is, could you please tell me to whom I should apply? I am particularly interested in the movies directed by Steven Spielberg, namely *Close Encounters of the Third Kind*, *Raiders of the Lost Ark*, and *E.T.*

Giorgio Rovesi
Villaggio Italcementi 9
24022 Alzano Lombardo
BG, Italy

See the ad for Script City in the CINEMAGIC Marketplace section of this issue.

Prop Master Wanted

... Is there anyone out there who can make realistic-looking laser rifles and pistols, costumes and miniatures? If you would be interested in helping me, please contact me at the address below.

Matthew Edwards
36-C Tide Village
St. Croix, U.S.V.I. 00820

Finding A Film School

... I am writing to request your guidance. I am a freshman at Clear Creek High School in League City, Texas. My interests are in the area of "special effects and set design" and I would like to have your suggestions concerning preparation for a professional career.

It would be helpful if you could direct me to some professionals who would be willing to advise me on what high school and college courses that I need to take. I am especially interested in learning which colleges or universities offer the best preparation for this field of the art. I don't even know where to start, but I do know this is what I want to do.

Patrick D. Ellis
18619 Prince William
Houston, TX 77058

Petersen's College Guides used to publish the American Film Institute Guide to College Courses in Film and Television. Unfortunately this excellent guide book is no longer published, but you should be able to find it in a local library. Petersen's Guides are now available on line through Compu-Serve. Use your own home computer (if you have one) to conduct your own film school search.

Stuntman Services

... I am a stuntman interested in corresponding with any filmmakers needing my services. For this purpose, I am presently compiling a video resume of my work. That work includes high falls, car hits, motorcycle falls, motorcycle to truck transfers, drags, stair falls, mountain climbs, and repels, I recently ventured into the art of sword-fighting, and have worked much with horses in the past. Fight scenes are a specialty of mine which I have not only participated in, but have coordinated as well. These fight scenes varied in style from martial arts, to boxing, to "free for all" brawls.

For amateur films, I am willing to work for free. All I ask for is a clip of my stunts performed.

Any filmmakers, amateur or professional in the Sacramento area, can contact me by mail at the following address. Any potential stuntmen in this area interested in getting together on stunts, please, contact me, also.

Dan B. St. Duran
5320 Jerrett Way
Sacramento, CA 95842

Potatoe-Eyed Producer

... I am an 18-year-old filmmaker/video producer that needs your help. I produce a television show called *Spudvision*, which consists entirely of films and videos produced by amateur, semi-professional, and student filmmakers. The more films and videos I can get, the more shows I can make. If I can make enough shows, I will be able to syndicate nationally over small, low-power broadcast or cable television stations, getting your films exposed to lots of people. And if I can get advertisers, I will be able to pay the people whose films we use.

Another thing I can accomplish by doing this is forming a national network of filmmakers called The Spudvision Network where all members would receive a quarterly newsletter and membership card. I then would be able to get the members in your area to contact each other so you would be able to make films or videos with each other. You would also be able to contact people in your area with special talents, such as makeup artists and FX people.

For a free membership or information on sending your films to *Spudvision*, please write me at the Address below. Please be sure to include a self-addressed, stamped envelope.

Spudvision
c/o David Foss
887 Woodmar Dr.
Crystal Lake, IL 60014

Flashy Logo Wanted

... I am looking for someone interested in creating a "Flashy" logo-introduction for my films. I'm looking for something bright, dazzling, eye-catching and colorful. If you think you can create something that fits my needs, and have the talent to do it, please contact me.

Exodus Film Productions
c/o John Martin
1920 West River Rd. South
Elyria, OH 44035

Seeking Super-8 Services

... Over the past several years, video popularity has increased. Due to this, I am finding it difficult to locate certain Super-8 services. It seems that most laboratories that used to offer them have now switched to video, or have gone out of business. I've talked to numerous people and labs, but this always seems to be the case. Examples are I.C.L. (International Color Lab), Alpha Cine, M.P.L. (Motion Picture Lab), and SuperCine.

I am doing some travelling mattes and I need a negative of the mattes I have to produce counter-mattes. I tried to find someone who could make a Super-8 internegative, but didn't. An optical blow-up would work, going to a 16mm internegative and then having a reduction print, but no one could do this either. Do you know of any lab that offers these types of services for Super-8 users? I am getting tired of hand-articulated mattes.

Kevin Crowder
51 Yellow Brick Rd.
Stillwater, OK 74074

If anyone can help Kevin, please contact him. Kevin, try contacting the "Norwegian FX Artist" Karl-Erik Ruud whose letter also appears in this section.

Ten Commandments

... Thank you for your letter: I remember our talk a long time ago and it is nice hearing from you again. I'm pleased you thought to send me the article and I want to congratulate you on its quality. I'm delighted I was able to make a contribution to it. I'll look forward to seeing the expanded version in the book you plan. Until then, my best wishes and my thanks.

Charlton Heston
Los Angeles, CA

Author Paul Mandell forwarded this thank you letter to our office, after copies of CINEMAGIC featuring our Ten Commandments FX articles had been sent to Heston. Mandell is currently preparing a comprehensive study of special effects with special emphasis on the most spectacular sequences ever filmed.

Norwegian FX Artist

... I am a 22-year old Norwegian optical FX artist who works in Super-8. I have recently finished building a two-headed optical printer. Anyone who wants good optical effects, please write to me. Here are some examples of what I am able to do with the printer: All types of compositing, posterization, all types of travelling mattes, laser and ray effects, and combinations of those effects mentioned above. The possibilities are endless, so it is better to ask me if I am able to create your effect.

Here is a tip to those of you who are looking for good engine effects for your space models: First, glue a piece of 3M front-projection material in your engine. Then put a regular glass plate at a 45-degree angle in front of your camera lens, and a slide projector at a 45 degree angle to your glass plate (90 degrees to the front of your camera lens). Put color filters in front of your projector lens. Read the light meter, and lock it before you start the slide projector and start filming.

Anyone who wants to correspond with me, please write.

Karl-Erik Ruud,
Krakeveien 29,
N-1500 Moss,
Norway

California Cinemagician

... I am 15 and would like to get in contact with anyone in the Oakland/San Francisco area who is interested in creating dazzling, spellbinding films. I would also like some script ideas for making a film with a comedic slant. Please write to me.

Kevin McNutt
32 Chatsworth Court
Oakland, CA 94611

Winging It

... Recently while making an 8mm film I decided to enhance a scene by adding a small flying creature to the background (ala *King Kong*). Little did I realize that making wings for this creature would become such a challenge.

Things were moving too smoothly, I had designed the creature (a cross between a one-eyed bat and a manta) in about an hour and made the armature and sculpted him in about two. Even the two-piece plaster of paris mold came off without a hitch, but when it came time to create the beast's wings all work came to a screaming halt.

I was stumped. I had built many animation models but never one with wings. The more I thought about it the more I wanted the wings to look real and perform well during anima-

tion. A friend suggested cutting the wings from a plastic bag and gluing them to the armature with latex. This approach had a few pitfalls. First, the plastic was stiff and unrealistic, and secondly, the acrylic and latex paint peeled off easily.

All was not lost, from this experiment came the final solution. I realized that if I painted latex on a cement walk and let it dry there, one side would have a bumpy sort of scaly finish for the top of the wing, and the other side would be smooth, perfectly suiting the fleshy underside. I set the wing armature to the flapped position and drew a pattern around it on paper. I placed the pattern on the fully dried latex skin and traced with a pen. Next I turned the pattern over and repeated the process. Once trimmed, the wings were fairly thin but strong enough to resist tearing when bent. Next, I glued the wing down onto the wire armature stays with Krazy glue. Krazy glue is the perfect adhesive for this job, because it adheres to both metal and rubber without reacting with either. When the glue dried I applied latex to the joint between the body and the wing, making it smooth and almost unnoticeable. I mixed up a slightly thicker than usual batch of paint for the stays, as it

would be all that covered them. The rest of the wing got a thinner coat to avoid hiding a single detail.

The beauty of making wings with this method is that anybody can make them quickly and can vary the design on the wings by simply pouring the latex on different surfaces. After finishing the creature, which I later named Geeter, I realized that even the smallest effect can be an unexpected challenge.

Peter Weissenberg
12439 Persimmon Rd.
Upper Marlboro, MD 20772

A Direct Line!

... Readers who have access to CompuServe can contact CINEMAGIC's Editor David Hutchison directly through Easyplex E-Mail. His User I.D. is 71036,1477. He can also be reached through M.C.I. Mail #136-7254.

Address all correspondence to:
CINEMAGIC—Filmmakers' Forum, c/o Starlog Press, Inc.,
215 Park Avenue South, New York, NY 10003.

Due to the enormous volume of mail received, the editor regrets that individual replies are impossible.

NIZO INTEGRAL 7

A New Dimension in Filming

- Lens: f/1.2 7-50mm 7:1 Schneider macro w/ power zoom.
- Exposure: TTL metering, automatic w/ full manual override.
- Film Speeds: Single frame, 18, 24 fps.
- Sound: Built-in boom mike.
- Special Effects: Fade-in/out, 5 & 15 second time-lapse
- Options: 4mm ultra-wide lens, mike extension, nicad batteries.



From:
Super8 Sound
"The Source for Super8"
95 Harvey St., Cambridge
MA 02140
(617) 876-5876

For complete details on all Super8 Equipment & Supplies send \$3.00 for the Super8 Sound "Info Pack"

Stop-Motion STUDIO

By CARL KÜRTE

ILLUSION ENGINEERING

A mid-western company creates high quality armatures, affordable by both amateurs and pros.

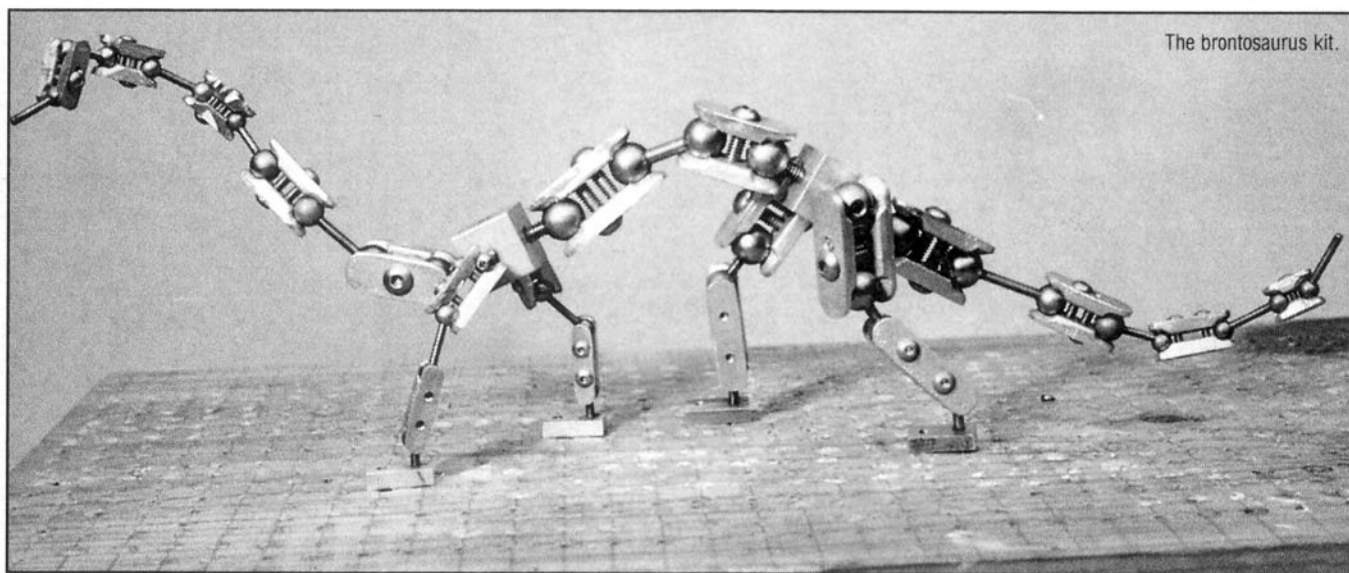

The brontosaurus kit.

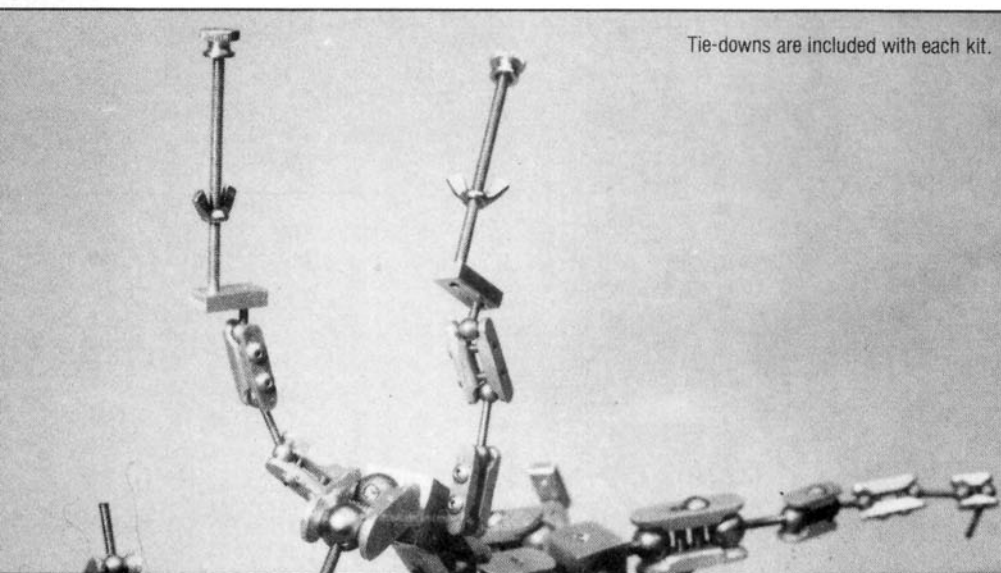

Tie-downs are included with each kit.

armatures have been individually designed and machined by hand—a very expensive, time consuming process that requires precision tools and very professional know-how. Custom machined armatures costing \$100 an inch (and up) are not unusual. But not everyone has the resources of Ray Harryhausen or the big budgets of George Lucas. Few filmmakers have the desire to become first rate machinists.

Fantasy filmmaker Tom Sullivan had to face these problems when he started working in animation as a youngster. "My first armature was made out of popsicle sticks and wooden macrame balls. It worked pretty well, but it was not strong enough to support a foam rubber body. My first steel armature took 40 hours to build with a hack saw and drill. It was unreliable and therefore unusable."

Sullivan confided his frustrations with an old friend, engineer Bob Meese. Together they have worked for many years to develop new materials and new approaches to armature construction that would benefit from the efficiencies of mass production—low cost, but without sacrificing quality.

Meese discovered that the key to mass

The most beautifully sculpted creature in the world is no better than a lump of shapeless clay, if the armature inside does not perform properly. A good armature must allow your creature to move realistically. It must support the creature's weight—often in extreme

positions of precarious balance. It must be strong enough to survive thousands of minute position changes without failure. It must move when the animator wants it to move and hold any position the animator requires.

Traditionally, the best ball-and-socket



Tom Sullivan, the artist half of Illusion Engineering, displays some of his work.

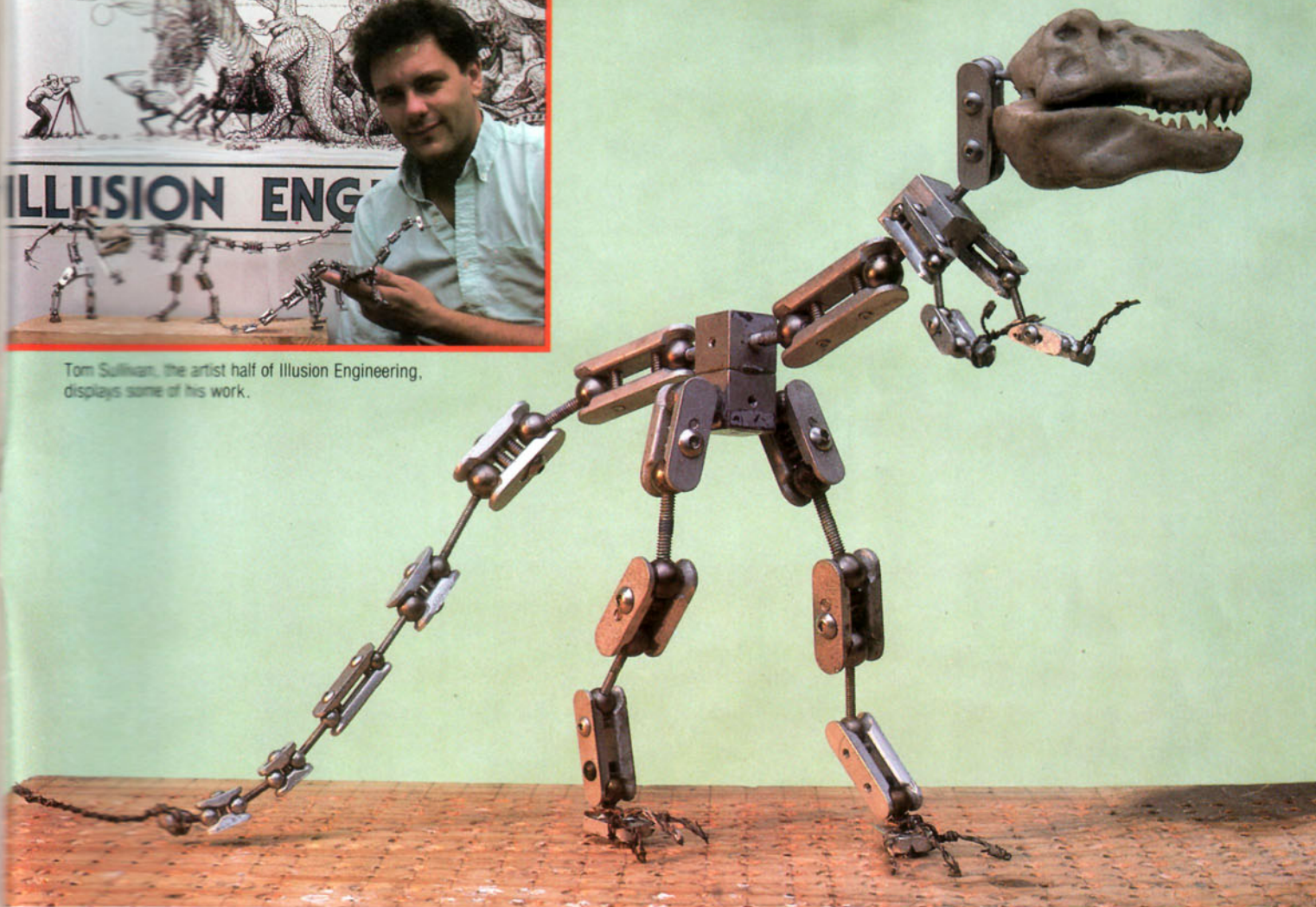

The tyrannosaurus rex armature kit. Head and wire details are not included with the kit.

production was in the selection of the special aluminum alloy that was selected for the plates. This alloy is primarily used in aerospace industries, since it has the same tensile strength as medium grade cast iron, but with all the lightness of aluminum. The metal is alloyed with silver, which brings the cost to eight or ten times that of ordinary aluminum. The alloy is not available in bar stock, which means you could never machine it into armature parts. The alloy is melted, poured into molds and heat treated. Casting plates for the sockets in this manner produces parts of extraordinary strength and absolute uniformity. Drilling and tapping holes are the only hand machining steps remaining in the process.

The remaining parts of the armature kits consist of stainless steel rods, nickel-plated, high strength aluminum balls and stainless steel screws. The nickel plating assures a smoothly rotating joint without any of the freezing or sticking that characterizes an aluminum-to-aluminum joint.

"Our armatures have been used all over the United States, and in Japan and Australia for several years," Meese affirms. "Only one piece has ever been returned and that was because a hole was mis-threaded. We've never had a part failure.

We use a special stainless steel button-head fastener, which cannot bend the socket plates no matter how tight you make them. Ultimately, you will strip the threads off the screw before you bend the plate."

But for all its strength, the materials are amazingly light weight. Meese reports that he routinely sends out a complete one-foot high human armature in a one-pound overnight Federal Express envelope.

Though originally designed to solve the problems of low-budget and amateur filmmakers, Illusion Engineering has been supplying parts to the big boys as well. Currently, they are producing miniature and full-scale armatures for *Evil Dead II*, which is filming in North Carolina. Tom Sullivan is in charge of the animation FX, as well as supplying expertise for the special makeup FX. Fantasy fans will be pleased to learn that the magic of animation and special effects will outweigh the blood and gore in this sequel.

Interested filmmakers can write for their 32-page catalog, which fully describes their line of stop-motion armatures and accessories. Send \$3.00 (refundable with your first order) to Illusion Engineering Inc., P.O. Box 526, Marshall, MI 49068.

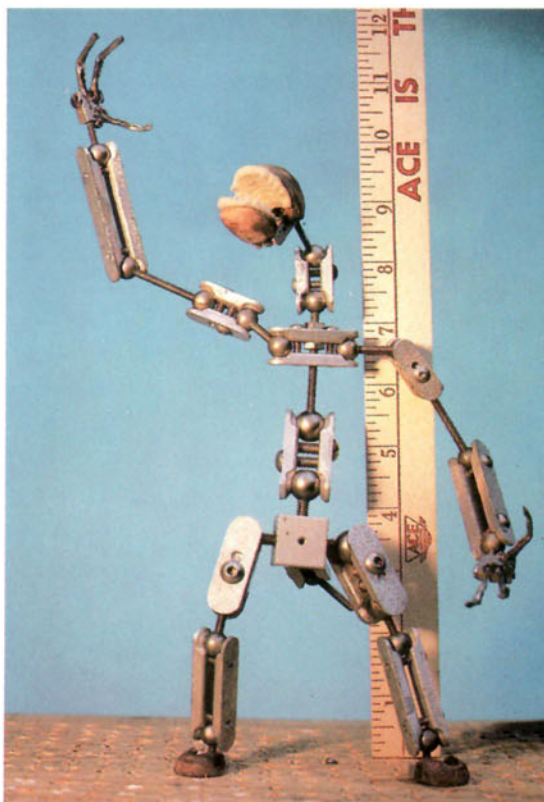

Skull and hands are not included in this gorilla armature kit, but are easily crafted.

**YOUR PERSONAL
PASS TO**

A UNIVERSE OF WONDER AND THRILLS!

STARLOG

The most popular science fiction magazine in the solar system brings you all the latest news, TV and film previews, special effects secrets, interviews with actors, authors, artists, even astronauts! And more!

FANGORIA

The magazine of movie chills and terror, featuring page after page of "bloody good" color photos, scenes from new splatter films, interviews with stars, special effects make-up artists, movie directors, writers, actors—all the news from the world of horror!

CINEMAGIC

This is the magazine for all young film and video makers—the only publication that teaches the techniques of production and special effects. New equipment reviews, how to contact other filmmakers in your area, low-budget tricks and tips.

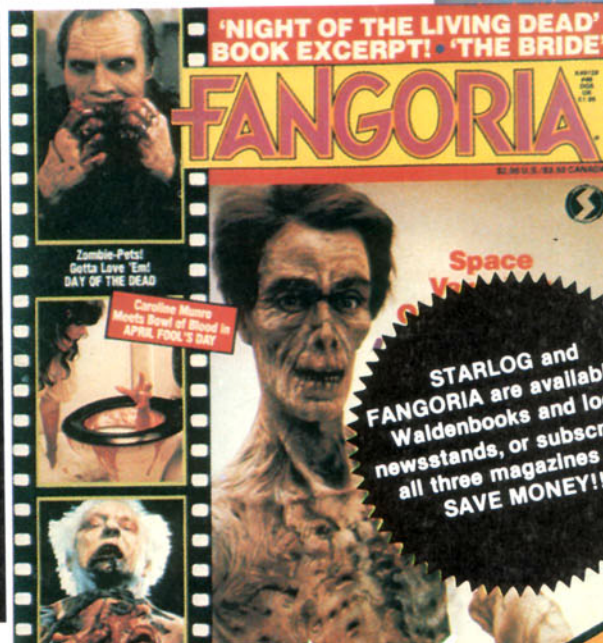

**"STARLOG is a lusty giant, symbolic of the new stature of science fiction in the visual media."
—ISAAC ASIMOV**

DISCOUNT SUBSCRIPTION FORM:

- STARLOG**
12 issues/1 year \$27.49
— Foreign: \$36.49
- FANGORIA**
9 issues/1 year \$16.98
— Foreign: \$22.98
- CINEMAGIC**
4 issues/1 year \$13.98
— Foreign: \$18.98

Total Enclosed \$
(cash, check or money order drawn to O'QUINN STUDIOS)

NAME _____
ADDRESS _____
CITY _____
STATE _____ ZIP _____
COUNTRY _____

Please allow 4 to 9 weeks for delivery of first issue
Foreign orders, send U.S. funds only

O'QUINN STUDIOS
475 Park Ave. South
New York, NY 10016